

Ref. : JT4203 .pas

Rev. : D

Date : 31/03/2020

Page : 1/1

JAUSBAUSTÜCK**PN10****JT4203**
Tecofi'
 VALVE DESIGNER - FRANCE
**EINSATZ**

Erleichterung der Montage-/Demontage von Rohrleitungsarmaturen. Geeignet für Wasseraufbereitung, Trinkwassersysteme usw.

MERKMALE

Nennweite: DN200 bis DN2000.
Anschluss PN10.

WERKSTOFFE

6	-	Scheibe	Stahl	Dacromet 500®
5	-	Gewindestange	Stahl 4.8	Dacromet 500®
4	1	Dichtring	EPDM	WRAS
3	1	Halteflansch	Duktiler Guss EN-GJS-500-7	DIN: GGG50 ASTM: A536 70-50-05 BS: 500/7
2	1	Kurzer Flansch	Duktiler Guss EN-GJS-500-7	DIN: GGG50 ASTM: A536 70-50-05 BS: 500/7
1	1	Langer Flansch	Duktiler Guss EN-GJS-500-7	DIN: GGG50 ASTM: A536 70-50-05 BS: 500/7
Pos.	Anz.	Bezeichnung	Material	

**MAßE**

DN		e	L	D5	D4	n-m	Flanschstärke	Gewicht (kg)
mm	inch							
200	8"	25	210	340	295	M20*350*8	16+3	35,9
250	10"	25	225	400	350	M20*370*12	19+3	48,4
300	12"	25	240	455	400	M20*390*12	20.5+3	53,5
350	14"	25	240	505	460	M20*400*16	20.5+3	78
400	16"	25	250	565	515	M24*420*16	20.5+3	104
450	18"	25	270	615	565	M24*435*20	21.5+3	138
500	20"	25	270	670	620	M24*440*20	22.5+3	140
600	24"	25	290	780	725	M27*460*20	25+3	167
700	28"	25	300	895	840	M27*480*24	27.5+3	235
800	32"	25	315	1015	950	M30*500*24	30+3	324
900	36"	25	325	1115	1050	M30*500*28	32.5+3	380
1000	40"	25	335	1230	1160	M33*545*28	35+3	481
1200	48"	25	345	1455	1380	M36*580*32	40+3	526
1400	56"	25	355	1675	1590	M39*630*36	41+3	1250
1500	60"	25	375	1785	1700	M39*665*36	42+3	1450
1600	64"	25	375	1915	1820	M45*700*40	44+3	1550
1800	72"	25	395	2115	2020	M45*730*40	47+3	2350
2000	80"	25	415	2325	2230	M45*730*48	49+3	2650

Epoxy-Beschichtung, RAL 5015 Farbton, 250 µm stark - WRAS

Einstellbereich: ± e

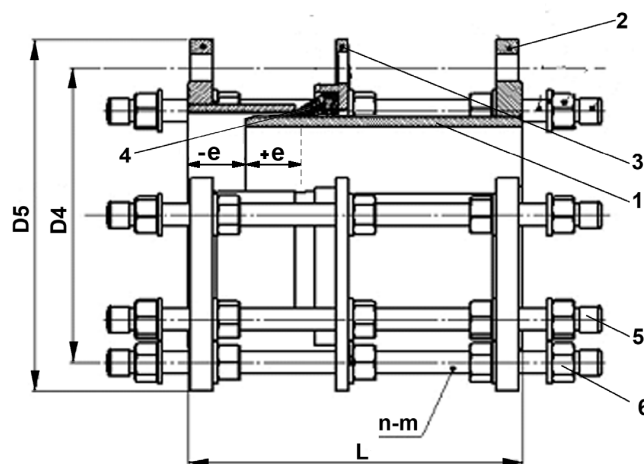
**BETRIEBSBEDINGUNGEN**

Max. Betriebsdruck: 10 bar.
Max. Betriebstemperatur: +4 °C / +110 °C

ZULASSUNGEN UND NORMEN

Druckprüfung gemäß: EN12266-1:
Gehäuse 15 bar.
Flanschanschluss EN 1092-2 PN10
Flanschanschluss EN 1092-2 PN10

TECOFI France - 83, Rue Marcel Mérieux 69960 Corbas - FRANCE
Tél. +33 (0) 4 72 79 05 79 - Fax +33 (0) 4 78 90 19 19 / +33 (0) 4 72 79 05 70
Adresses e-mail : sales@tecofi.fr / Site web : www.tecofi.fr