

## VPI LUG TECFLY RANGE - PREMIUM SERIE

TECHNICAL PASSPORT

### LUGGED TYPE BUTTERFLY VALVE DUCTILE IRON BODY - WITH HANDLE

VPI 4648-02

#### APPLICATION

VPE butterfly valves are intended for ON/OFF or control use in fluid transfer circuits.

**Area of use:** water treatment, pumping, irrigation, industry.



**Fluids:** cold water, hot water, lightly charged water, liquid discharges, compressed air, alkalis, sodium hydroxide, etc.

«Not suitable for steam application»



#### GENERAL CHARACTERISTICS

**Range:** from DN40 to DN300.

- Lugged type with threaded ears,
- Sealing in both directions of circulation of the piping.
- Soft sleeve guaranteeing a perfect tightness.
- Extended neck compatible with pipe insulation.
- Nickel plated ductile iron disc profiled and reduced in thickness
- Reduced maneuvering torque.
- Disc assembled with 2 non-ajectable half-shaft, square drive.
- Notched sector providing 10 positions of adjustment of the handle.
- ISO 5211 mounting plate allowing the installation of all types of actuators.

#### STANDARDS

<b>Design</b>	Design according to NF EN 593. Manufacture according to the requirements of the European directive 2014/68/UE «Equipment under pressure»: modulate H.
<b>Face to face</b>	Face to face according to standards NF EN 558 serie 20, ISO 5272 serie 20.
<b>Connection</b>	Mounting with flanges ISO PN10/16 from DN40 to DN150 and PN10 from DN200 to DN300 according to standard EN1092.
<b>Tests</b>	Pressure test according to standards EN12266-1 and ISO 5208: -Body : 24 bar -Seat : 17.6 bar

#### PRODUCT APPROVALS

CE EAC Ex On request

**Tecofi France**

83 rue Marcel Mérieux - 69960 Corbas  
Tél. +33 (0)4 72 79 05 79 - Fax. +33 (0)4 78 90 19 19  
E-mail : sales@tecofi.fr - [www.tecofi.fr](http://www.tecofi.fr)



## VPI LUG TECFLY RANGE - PREMIUM SERIE

### TECHNICAL PASSPORT

VPI 4648-02

### CONSTRUCTION & DIMENSIONS

Component	Coating
Body (1)	Oven backed epoxy coated RAL5015, 150 microns thickness
Disc (2)	Oven backed epoxy coated RAL3013, 150 microns thickness

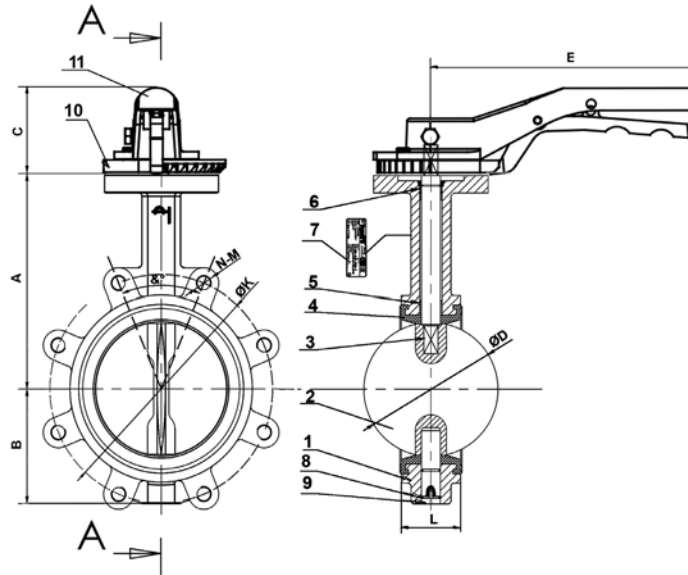

Pos.	Q-ty	Description	Material	Equivalences		
				DIN	ASTM	BS
1	1	Body	Ductile iron EN-GJS-500-7	GGG50	A536 70-50-05	EN-JS1050
2	1	Disc	Ductile iron EN-GJS-500-7	GGG50	A536 70-50-05	EN-JS1050
3	2	Shaft	Stainless steel 410			
4	1	Sleeve	Heat EPDM			
5	4	Bushing	PTFE			
6	1	O ring	NBR			
7	1	Nameplate	Stainless steel 304	X5CrNi 18 10	A 182 AISI 304	1449-2 304 S15
8	1	Circlips	Steel			
9	1	Bottom cover	Plastic			
10	1	Notched quadrant	Aluminium			
11	1	Handle	Ductile iron			

DN		L	A	B	C	Ø D	Ø K	E	N-M	&°	Weight (kg)
mm	inch										
40	1 1/2	32.5	135	52	52.5	39.2	110	180	4-M16	90°	2.50
50	2	42.5	140	60	52.5	52.9	125	180	4-M16	90°	3.10
65	2 1/2	45.5	150	70	52.5	64.5	145	180	4-M16	90°	3.70
80	3	45.5	156	91.6	52.5	78.8	160	180	8-M16	90°	4.90
100	4	51.5	169	90	52.5	104	180	180	8-M16	45°	6.00
125	5	55.5	190	105	50	123.3	210	220	8-M16	45°	9.40
150	6	55.5	200	120	50	155.1	240	220	8-M20	45°	10.50
200	8	59.5	224	158	57	202.5	295	450	8-M20	45°	20.70
250	10	67.5	265	197	57	250.5	350	450	12-M20	30°	27.80
300	12	77.5	303	230	57	301.5	400	450	12-M20	30°	35.60

**Tecofi France**

83 rue Marcel Mérioux - 69960 Corbas

Tél. +33 (0)4 72 79 05 79 - Fax. +33 (0)4 78 90 19 19

E-mail : sales@tecofi.fr - [www.tecofi.fr](http://www.tecofi.fr)



**WORKING CONDITIONS**

Maximum working pressure : 16 bar  
(6 bar for compressed air)  
Maximum working temperature : -15°C / +130°C  
Peak temperature : -30°C / +150°C

**Types of sleeve in option**

Tightness	Maximum temperature	Peak temperature
EPDM	Tmax : +4°C / +110°C	- 20°C / +130°C
White EPDM	Tmax : +4°C / +110°C	- 20°C / +130°C
CSM (Type Hypalon®)	Tmax : +4°C / +80°C	- 20°C / +110°C
FPM (Type Viton®)**	Tmax : -10°C / +150°C (+170°C)	- 20°C / +150°C (+200°C)
Silicone**	Tmax : -20°C / +150°C (+170°C)	- 40°C / +150°C (+200°C)
Nitrile (NBR)	Tmax : -10°C / +80°C	- 20°C / +90°C

\*\* The maximum and peak temperatures must not exceed +150°C, the limit temperature for the disc's epoxy paint.

The photographs and technical art works are not contractual. The specifications of the presented products are open to modifications without previous advice.