

VPI TECFLY - PREMIUM RANGE

TECHNICAL PASSPORT

BUTTERFLY VALVE - DUCTILE IRON BODY WITH SINGLE ACTING PNEUMATIC ACTUATOR BETWEEN FLANGES

VPI 4448-N07

APPLICATION

VPI butterfly valves are intended for ON/OFF or control use in fluid transfer circuits.

Areas of use: water treatment, pumpage, irrigation, industry.



Fluids: cold water, hot water, lightly charged water, liquid discharges, etc.
«Not suitable for steam application»

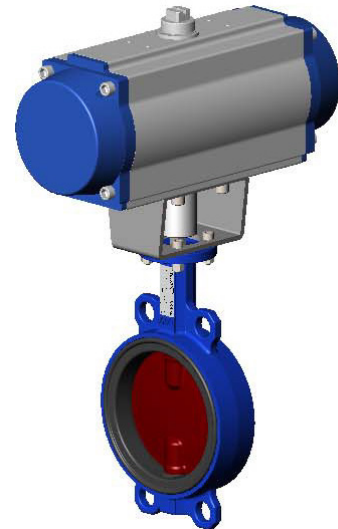

GENERAL CHARACTERISTICS

Range: from DN32/40 to DN300.

- Design with smooth ears enabling use on bottom line.
- Sealing in both directions of circulation of the piping.
- Soft sleeve guaranteeing a perfect tightness.
- Extended neck compatible with pipe insulation.
- Profiled and reduced disc
- Reduced maneuvering torque.
- Disc assembled with 2 non-ajectable half-shaft, square drive.
- ISO 5211 mounting plate allowing the installation of all types of actuators.

STANDARDS

Design	Design according to NF EN 593. Manufacture according to the requirements of the European directive 2014/68/UE «Equipment under pressure»: modulate H.
Face to face	Face to face according to standards NF EN 558 série 20, ISO 5272 série 20.
Connection	Mounting between flanges ISO PN10/16 according to EN1092, ISO 7005-1. Adjustable between flanges ASME B16.5 Classe 150 and JIS 10K. GOST PN10/16.
Tests	Pressure test according to standards EN12266-1 and ISO 5208: - Body : 24 bar - Seat : 17.6 bar

PRODUCT APPROVALS

CE EAC Ex On request

Tecofi France

83 rue Marcel Mérieux - 69960 Corbas
Tél. +33 (0)4 72 79 05 79 - Fax. +33 (0)4 78 90 19 19
E-mail : sales@tecofi.fr - www.tecofi.fr



VPI TECFLY - PREMIUM RANGE

TECHNICAL PASSPORT

VPI 4448-N07

CONSTRUCTION & DIMENSIONS

Component	Coating
Body (1)	Oven backed epoxy coated RAL5015, 150 microns thickness
Disc (2)	Oven backed epoxy coated RAL3013, 150 microns thickness

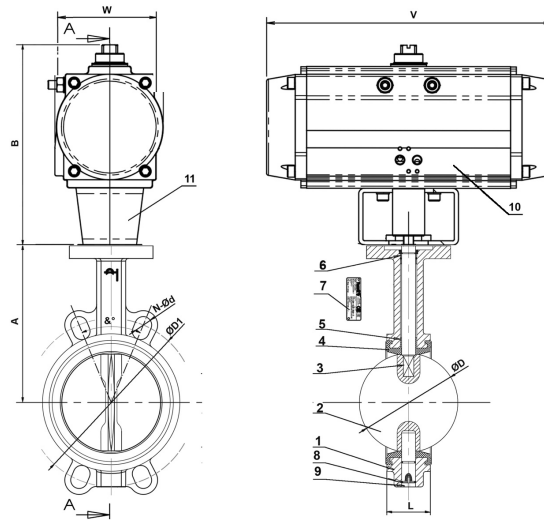

Pos.	Q-ty	Description	Material	Equivalences		
				DIN	ASTM	BS
1	1	Body	Ductile iron EN-GJS-500-7	GGG50	A536 70-50-05	EN-JS1050
2	1	Disc	Ductile iron EN-GJS-500-7	GGG50	A536 70-50-05	EN-JS1050
3	2	Shaft	Stainless steel 410			
4	1	Sleeve	Heat EPDM			
5	4	Bushing	PTFE			
6	1	O ring	NBR			
7	1	Nameplate	Stainless steel 304	X5CrNi 18 10	A 182 AISI 304	1449-2 304 S15
8	1	Circlips	Seel			
9	1	Bottom cover	Plastic			
10	1	Pneumatic actuator				
11	1	Yoke *				

* - Yoke in stainless steel 304 replaced by an aluminium spacer on DN32/40-125 and DN200.

DN		A	B	L	Ø D	Ø D1	N-Ød	&°	W	V	Actuator model	Weight (kg)
mm	inch											
40	1 1/2"	120	128	33	39.2	110	4-19	90°	80.5	169	TSR-063	3.8
50	2"	140	128	43	52.9	125	4-19	90°	80.5	169	TSR-063	4.4
65	2 1/2"	150	149	46	64.5	145	4-19	90°	91	210	TSR-083	6.3
80	3"	156	157	46	78.8	160	4-19	90°	103	264	TSR-092	8.3
100	4"	175	170	52	104	180	4-19	45°	116	272	TSR-105	10.8
125	5"	190	202	56	123.3	210	4-19	45°	134.5	302	TSR-125	16.1
150	6"	211	282	56	155.1	240	4-23	45°	142	398	TSR-140	25
200	8"	235	249	60	202.5	295	4-23	45°	161	456	TSR-160	37
250	10"	265	330	68	250.5	355	4-28	30°	189	534	TSR-190	57.4
300	12"	305	355	78	301.5	410	4-28	30°	210	536	TSR-210	85

Tecofi France

83 rue Marcel Mérieux - 69960 Corbas
 Tél. +33 (0)4 72 79 05 79 - Fax. +33 (0)4 78 90 19 19
 E-mail : sales@tecofi.fr - www.tecofi.fr

ISO 9001
 ISO 14001
 BUREAU VERITAS
 Certification



WORKING CONDITIONS

Maximum working pressure : 16 bar
(6 bar for compressed air)
Maximum working temperature : -15°C / +130°C
Peak temperature : -30°C / +150°C

Types of sleeve in option

Tightness	Maximum temperature	Peak temperature
EPDM	Tmax : +4°C / +110°C	- 20°C / +130°C
White EPDM	Tmax : +4°C / +110°C	- 20°C / +130°C
CSM (Type Hypalon®)	Tmax : +4°C / +80°C	- 20°C / +110°C
FPM (Type Viton®)**	Tmax : -10°C / +150°C (+170°C)	- 20°C / +150°C (+200°C)
Silicone**	Tmax : -20°C / +150°C (+170°C)	- 40°C / +150°C (+200°C)
Nitrile (NBR)	Tmax : -10°C / +80°C	- 20°C / +90°C

** The maximum and peak temperatures must not exceed +150°C, the limit temperature for the disc's epoxy paint.

The photographs and technical art works are not contractual. The specifications of the presented products are open to modifications without previous advice.