

Ref. : VP 4649-02PTF

Rev. : Initial

Date : 16/12/2014

Page : 1/1

PTFE LUG TYPE BUTTERFLY VALVE

VP 4649-02PTF



Tecofi'
VALVE DESIGNER - FRANCE

APPLICATION

General use : for corrosive fluids (acids ...)

GENERAL CHARACTERISTICS

From DN40 to DN200.
Long neck for isolation
ISO 5211 mounting pad, lug type.
2 parts body and stem.
Stainless steel PTFE coated disc.
PTFE sealing ring 3 mm thickness
with silicone elastic gasket 6 mm thickness.
Rilsan coated body color RAL 5024 ,
250-300 microns thickness
9 positions handle, with locking device.

CONSTRUCTION

14	Handle	Aluminium
13	Screw	A4
12	O ring	FKM
11	O ring	FKM
10	Socket	Stainless steel 316
9	Ring	Stainless steel 316
8	Plate screw	A4
7	Washer	A4
6	Plate	Aluminium
5	Insert	Silicone
4.1	Lower stem	Stainless steel 17 4-PH (630)
4	Upper stem	Stainless steel 17 4-PH (630)
3	Sleeve	PTFE
2	Disc	Stainless steel ASTM A351 CF8M
1	Body	Ductile iron EN-GJS-500-7
Pos.	Description	Material

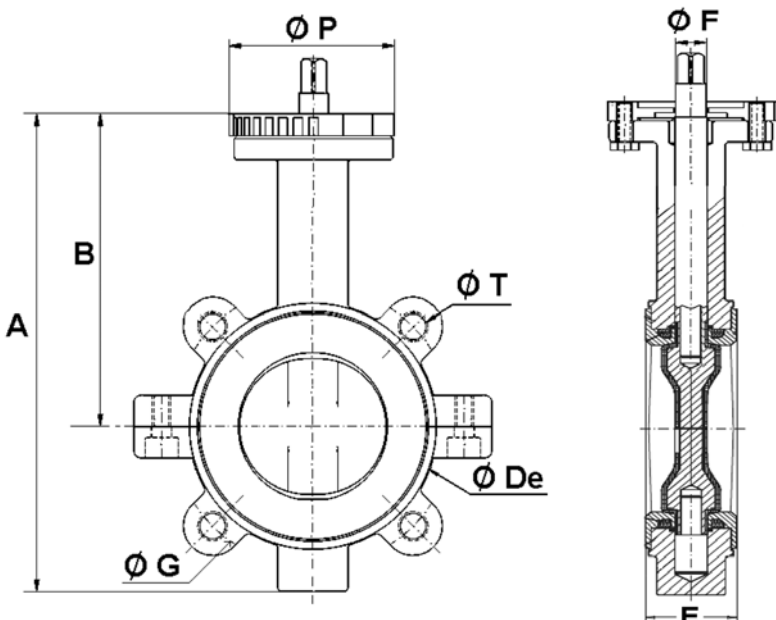
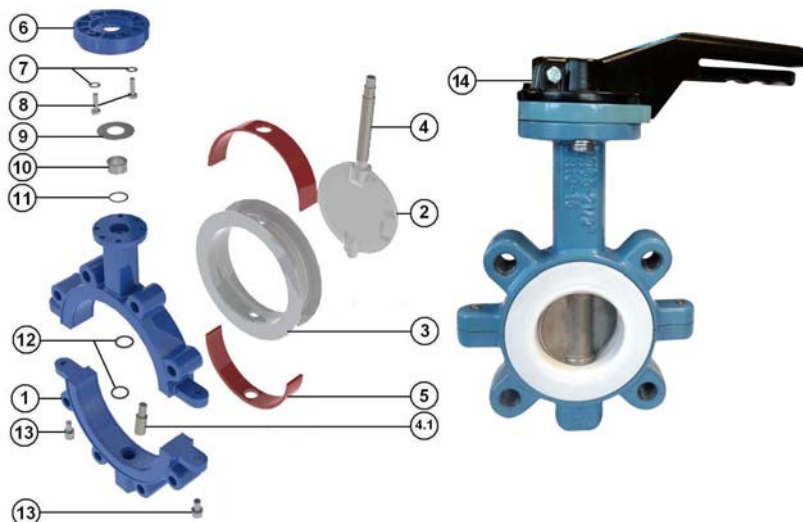

DIMENSIONS

DN		A	B	ØDe	E	ØF	ØG	ØP	ØT	Weight (kg)
mm	inch									
40	1 1/2	205	140	82	33	10.5	110	88	4 x M16	3
50	2"	226	156	103	43	10.5	125	88	4 x M16	4
65	2 1/2	242	161	116	46	14.5	145	88	4 x M16	5
80	3"	257	167	134	47	16.5	160	88	8 x M16	6.5
100	4"	288	184	153	52	16.5	180	88	8 x M16	8
125	5"	325	207	185	56	18.5	210	105	8 x M16	11
150	6"	346	215	208	56	18.5	240	105	8 x M20	13
200	8"	437	257	270	60	22.5	295	105	8 x M20	22

WORKING CONDITIONS

Maximum working temperature : -25°C / 200°C
Maximum working pressure: 16 bar from DN40 to DN150
10 bar for DN200

STANDARDS

Fabrication according to ISO 9001:2008
Tests according to ISO 5208, range A
Between flanges according to EN 1092-1 PN10
Length according to ISO 5752 short series 20, EN 558 series 20 (NF 29305), BS 5155 Wafer short/medium, DIN 3202 part 3, series K1.

Handle types

DN 40 – 100

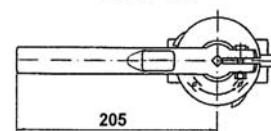

DN 125 – 200

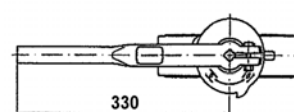

TECOFI France - 83, Rue Marcel Mérieux 69960 Corbas - FRANCE
Tél. +33 (0) 4 72 79 05 79 - Fax +33 (0) 4 78 90 19 19 / +33 (0) 4 72 79 05 70
Adresses e-mail : sales@tecofi.fr ; tecofi@tecofi.fr / Site web : www.tecofi.fr