

FLANGED BUTTERFLY VALVE

TECHNICAL PASSPORT

BUTTERFLY VALVE WITH GEAR BOX FLANGED MODEL TECFLY DUCTILE IRON BODY

VP 4548A-08

APPLICATION

The VP butterfly valves are intended to be used in ON/OFF mode or regulation in the fluid transfer circuits.

Area of use: water treatment, pumping irrigation.



Fluids: cold water, hot water, waste water, liquid discharges, alkalis, sodium hydroxide, etc.



GENERAL CHARACTERISTICS

Range: from DN50 to DN300.
Design according to NF EN 593.
Sleeve ensuring tightness in both directions.
Crossing stem. Profiled and reduced thickness disc ensuring a reduced operating torque.
Standardized mounting plate according to ISO 5211.

WORKING CONDITIONS

Maximum working pressure : 16 bar
Maximum working temperature : -15°C / +130°C
Peak temperature: -30°C / +150°C

STANDARDS

Design	Manufacture according to the requirements of the European directive n° 2014/68/UE «Equipment under pressure» : modulate H.
Face to face	Face to face dimensions according to NF EN 558-1 serie 20, ISO 5272 serie 20, DIN 3202.
Connection	Flanged type ISO PN10/16 (DN50-150) and PN16 (DN200-300) according to EN1092-2.
Tests	Pressure test according to standards EN12266-1, DIN 3230, BS 5154 and ISO 5208: -Body : 24 bar -Seat : 17.6 bar

PRODUCT APPROVALS



Tecofi France

83 rue Marcel Mérieux - 69960 Corbas
Tél. +33 (0)4 72 79 05 79 - Fax. +33 (0)4 78 90 19 19
E-mail : sales@tecofi.fr - www.tecofi.fr



FLANGED BUTTERFLY VALVE

TECHNICAL PASSPORT

VP 4548A-08

CONSTRUCTION

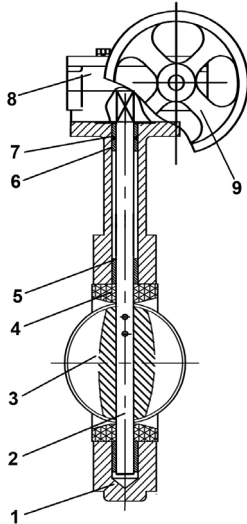

Pos.	Q-ty	Description	Material	Equivalences		
				DIN	ASTM	BS
1	1	Body	Ductile iron EN-GJS-400	GGG40	A536 65-45-12	EN-JS1030
4	1	Stem	Stainless steel 410	X12Cr13		
2	1	Disc	Ductile iron EN-GJS-400	GGG40	A536 65-45-12	EN-JS1030
3	1	Sleeve	Heat EPDM			
5	2	Bushing	FRP			
6	2	Bushing	FRP			
7	1	O ring	NBR			
8	1	Gear box				
9	1	Handwheel	Cast iron EN-GJL-250	GG25	A48 class 40B	1452 Grade 250

DIMENSIONS

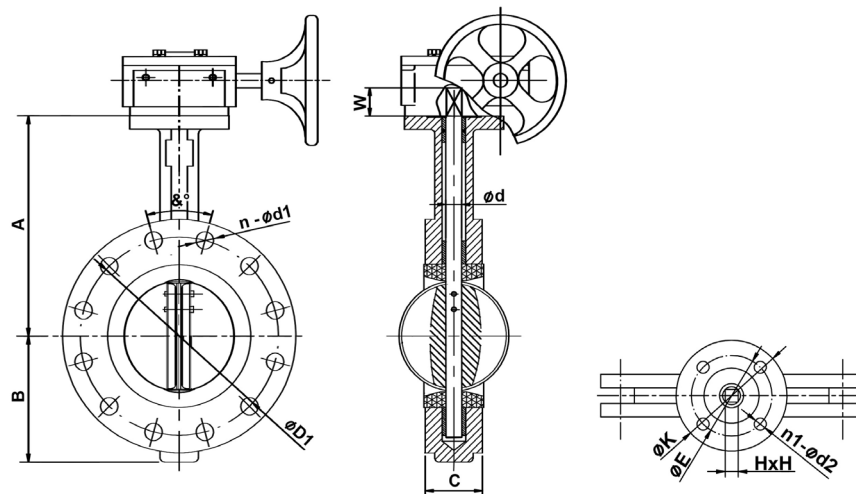

DN		A	B	C	Ød	ISO	ØK	ØE	n1-Ød2	ØD1	n-Ød1	α°	H	W	Weight (kg)
mm	inch														
50	2"	161	83	42	12.6	F05	65	50	4-Ø7	125	4-Ø19	90	9	32	8.00
65	2 1/2"	175	93	44.7	12.6	F05	65	50	4-Ø7	145	4-Ø19	90	9	32	8.30
80	3"	181	100	45.2	12.6	F05	65	50	4-Ø7	160	8-Ø19	45	9	32	9.52
100	4"	200	112	52.1	15.8	F07	90	70	4-Ø10	180	8-Ø19	45	11	32	12.40
125	5"	213	125	54.4	18.9	F07	90	70	4-Ø10	210	8-Ø19	45	14	32	13.70
150	6"	226	145	55.8	18.9	F07	90	70	4-Ø10	240	8-Ø23	45	14	32	16.30
200	8"	260	173	60.6	22.1	F10	125	102	4-Ø12	295	12-Ø23	45	17	45	26.80
250	10"	292	203	65.6	28.5	F10	125	102	4-Ø12	355	12-Ø28	30	22	45	39.00
300	12"	337	242	76.9	31.6	F10	125	102	4-Ø12	410	12-Ø28	30	22	45	59.80

Tecofi France

83 rue Marcel Mérieux - 69960 Corbas

Tél. +33 (0)4 72 79 05 79 - Fax. +33 (0)4 78 90 19 19

E-mail : sales@tecofi.fr - www.tecofi.fr

