

Ref. : VP 4509-08.pas

Rev. : A

Date : 08/07/2011

Page : 1/1

# FLANGED TYPE VALVE WITH GEAR BOX TECLARGE FL

## VP 4509-08



### APPLICATION

General use : water, sea water, sludge, etc.

### GENERAL CHARACTERISTICS

Design in accordance with NF EN 593.  
Tightness in both ways, NF EN 12266-1, ISO 5208, DIN 3230.  
Two kinds of sleeve:  
- body in dovetail shape ensures a perfect assembling (for high vacuum we can stick it),  
- sleeve internally reinforced in aluminium giving a low torque.  
Stem: half stem high and low or crossing stem depending on the diameter.  
Coupling stem on butterfly assembled by blind screw.  
Self lubricant bearing in copper alloy.  
Supplementary tightness on stem by o'rings.  
Dovetail type sleeve.

### CONSTRUCTION

Pos.	Qty.	Description	Material
7	1	Gear box	
6	2	Bottom cover	Cast iron EN-GJL-250
5	1	Upper stem	Stainless steel 410
4	1	Lower stem	Stainless steel 410
3	1	Sleeve	Heat EPDM
2	1	Disc	Stainless steel 316 GX5CrNiMo 19-11-2
1	1	Body	Ductile iron EN-GJS-400-15

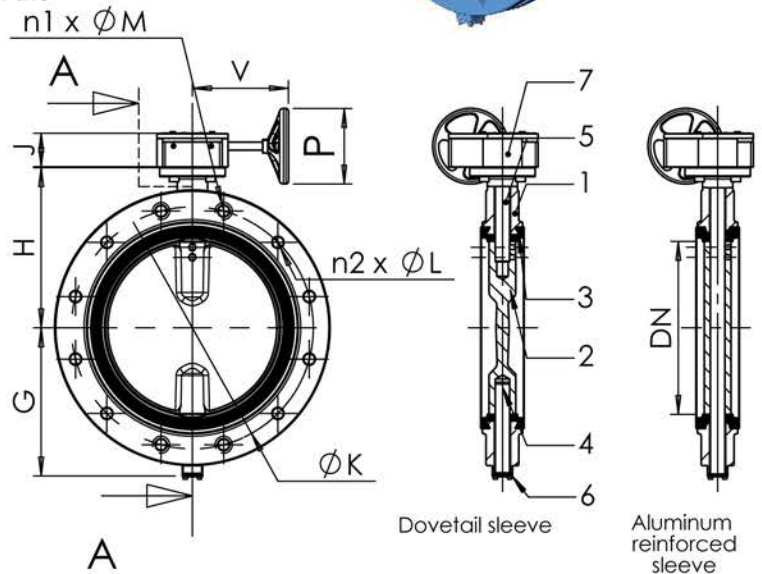

### DIMENSIONS

DN		Upper flange						Valve dimensions					Weight (kg)
mm	inch	ISO	ØD	ØD1	n x ØN	G	H	L	PN10**				
									ØK	n1 x ØM	n2 x ØL		
350	14"	F10	125	102	4 x Ø12	267	368	78(92)*	460	4 x M20	12 x Ø22	102	
400	16"	F14	175	140	4 x Ø18	309	400	102	515	4 x M24	12 x Ø26	128	
450	18"	F14	175	140	4 x Ø18	328	422	114	565	4 x M24	16 x Ø26	204	
500	20"	F14	175	140	4 x Ø18	361	480	127	620	4 x M24	16 x Ø26	234	
600	24"	F16	210	165	4 x Ø23	459	562	154	725	4 x M27	16 x Ø30	336	
700	28"	F25	300	254	8 x Ø18	520	624	165	840	4 x M27	20 x Ø30	504	
800	32"	F25	300	254	8 x Ø18	591	672	190	950	4 x M30	20 x Ø33	588	
900	36"	F25	300	254	8 x Ø18	656	720	203	1050	4 x M30	24 x Ø33	1044	
1000	40"	F25	300	254	8 x Ø18	721	800	216	1160	4 x M33	24 x Ø36	1215	
1200	48"	F30	350	298	8 x Ø23	860	900	254	1380	4 x M36	24 x Ø39	2054	

\* L = 92 on request

\*\* PN16 / ASA 150 on request

DN		Gear box		
mm	inch	V	P	J
350	14"	226	300	86
400	16"	255	300	105
450	18"	255	300	105
500	20"	285	400	120
600	24"	322	400	120
700	28"	367	450	125
800	32"	367	450	125
900	36"	426	500	200
1000	40"	426	500	200
1200	48"	506	550	273



### WORKING CONDITIONS

Maximum working pressure : 10 bar.  
Maximum temperature : -15 °C / +130 °C.  
Peak temperature : -30°C / +150°C.

### STANDARDS

Manufacture according to the requirements of the European directive 2014/68/UE «Equipments under pressure» : category III modulate H.  
Pressure test according to standards EN 12266-1, DIN 3230, BS 5154 and ISO 5208 :  
Body : 15,5 bar.  
Seat : 11 bar.  
Face to face according to standard EN 558-1 serie 20, ISO 5752 serie 20 and DIN 3202.  
Flanged type ISO PN10 connections according to standard EN 1092-2.

TECOFI France - 83, Rue Marcel Mérieux 69960 Corbas - FRANCE  
Tél. +33 (0) 4 72 79 05 79 - Fax +33 (0) 4 78 90 19 19 / +33 (0) 4 72 79 05 70  
Adresses e-mail : sales@tecofi.fr ; tecofi@tecofi.fr / Site web : www.tecofi.fr