

Ref. : VP 4409-08.pas

Rev. : I

Date : 03/02/2015

Page : 1/1

# WAFFER TYPE BUTTERFLY VALVE WITH GEAR BOX TECLARGE

## VP 4409-08



**Tecofi'**  
VALVE DESIGNER - FRANCE

### APPLICATION

General use : water, sludge, etc.

### GENERAL CHARACTERISTICS

Design in accordance with NF EN 593.  
Tightness in both ways, NF EN 12266-1, ISO 5208, DIN 3230.  
Two kinds of sleeve:  
- body in dovetail shape ensures a perfect assembling (for high vacuum we can stick it),  
- sleeve internally reinforced in aluminium giving a low torque.  
Stem: half stem high and low or crossing stem depending on the diameter.  
Coupling stem on butterfly assembled by blind screw.  
Self lubricant bearing in copper alloy.  
Supplementary tightness on stem by o'rings.  
Dovetail type sleeve.



### CONSTRUCTION

7	1	Gear box		
6	1	Bottom cover	EN-GJL-250	DIN: GG25 ASTM: A48 class 40B BS: 1452 Grade 250
5	1	Upper stem	Stainless steel 410	DIN: 1.4006 ASTM: AISI 410 BS: 410 S 21
4	1	Lower stem	Stainless steel 410	DIN: 1.4006 ASTM: AISI 410 BS: 410 S 21
3	1	Sleeve	Heat EPDM	
2	1	Disc	GX5CrNiMo19-11-2	DIN: G-X6CrNiMo18 10 ASTM: A351 Grade CF8M BS: 1504 316 C16
1	1	Body	EN-GJS-400-15	DIN: GGG 40 ASTM: A536 65-45-12 BS: EN-JS1030
Pos.	Qty.	Description	Material	

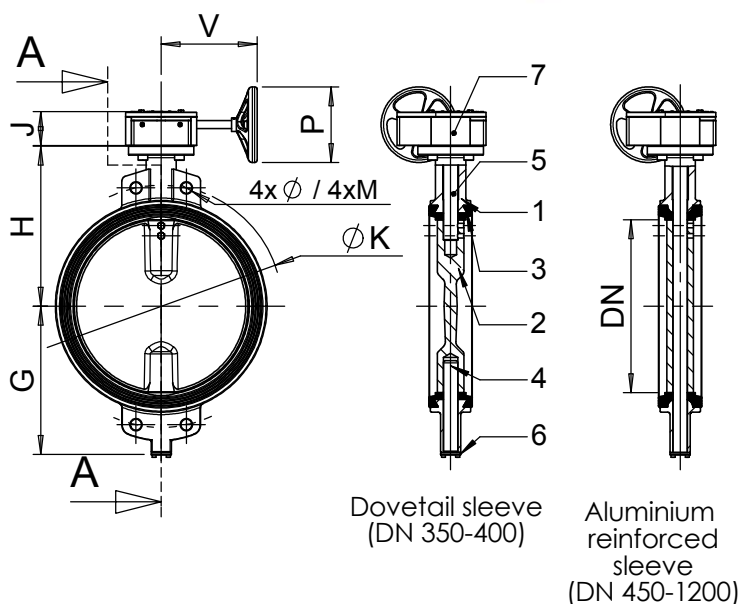

### DIMENSIONS

DN		Upper flange				Valve dimensions					
mm	inch	ISO	ØD	Ø D1	n x Ø N	G	H	L	PN10*		Weight (kg)
									Ø K	4xØ 4xM	
350	14"	F10	125	102	4 x Ø12	267	368	78(92)*	460	4 x Ø22	57
400	16"	F14	175	140	4 x Ø18	309	400	102	515	4 x Ø26	93
450	18"	F14	175	140	4 x Ø18	328	422	114	565	4 x Ø26	115
500	20"	F14	175	140	4 x Ø18	361	480	127	620	4 x Ø26	180
600	24"	F16	210	165	4 x Ø23	459	562	154	725	4 x Ø30	250
700	28"	F25	300	254	8 x Ø18	520	624	165	840	4 x Ø30	374
800	32"	F25	300	254	8 x Ø18	591	672	190	950	4 x Ø33	458
900	36"	F25	300	254	8 x Ø18	656	720	203	1050	4 x Ø33	914
1000	40"	F25	300	254	8 x Ø18	721	800	216	1160	4 x Ø36	1085
1200	48"	F30	350	298	8 x Ø23	860	900	254	1380	8 x Ø39	1854

\* PN16 / ASA 150 on request

DN		Gear box		
mm	inch	V	P	J
350	14"	226	300	86
400	16"	255	300	105
450	18"	255	300	105
500	20"	285	400	120
600	24"	322	400	120
700	28"	367	450	125
800	32"	367	450	125
900	36"	426	500	200
1000	40"	426	500	200
1200	48"	506	550	273

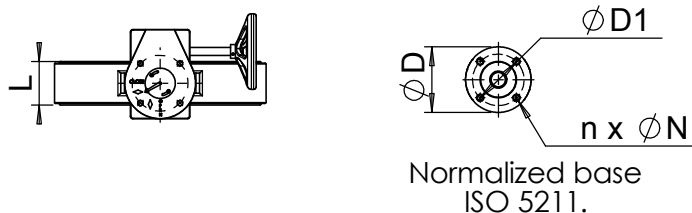

### WORKING CONDITIONS

Maxi working pressure: 10 bar.  
Maxi temperature: -15 °C / +130 °C.  
Peak temperature : -30°C / +150°C

### STANDARDS

Manufacture according to the requirements of the European directive 2014/68/UE «Equipments under pressure» : modulate H.

Pressure test according to standards EN 12266-1, DIN 3230, BS 5154 and ISO 5208 :  
Body : 15,5 bar.  
Seat : 11 bar.

Face to face according to standard EN 558-1 serie 20, ISO 5752 serie 20 and DIN 3202.

Wafer type ISO PN10 connections according to standard EN 1092-2.

**TECOFI France** - 83, Rue Marcel Mérioux 69960 Corbas - FRANCE  
Tél. +33 (0) 4 72 79 05 79 - Fax +33 (0) 4 78 90 19 19 / +33 (0) 4 72 79 05 70  
Adresses e-mail : sales@tecofi.fr ; tecofi@tecofi.fr / Site web : www.tecofi.fr