

Ref. : VP 4402-08.pas

Rev. : B

Date : 29/01/2015

Page : 1/1

WAFER TYPE BUTTERFLY VALVE WITH GEAR BOX TECLARGE

VP 4402-08



Tecofi'
VALVE DESIGNER - FRANCE

APPLICATION

General use : water, sludge, etc.

GENERAL CHARACTERISTICS

Design in accordance with NF EN 593.

Tightness in both ways, NF EN 12266-1, ISO 5208, DIN 3230.

Two kinds of sleeve:

- body in dovetail shape ensures a perfect assembling (for high vacuum we can stick it),
 - sleeve internally reinforced in aluminium giving a low torque.
- Stem: half stem high and low or crossing stem depending on the diameter.

Coupling stem on butterfly assembled by blind screw.

Self lubricant bearing in copper alloy.

Supplementary tightness on stem by o'rings.

Dovetail type sleeve.

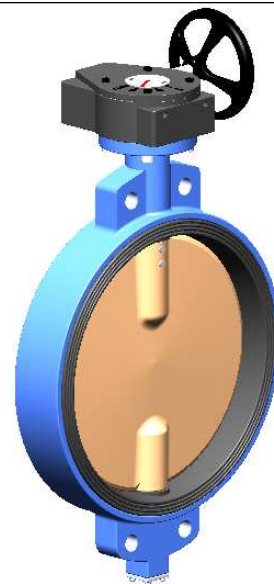

CONSTRUCTION

7	1	Gear box		
6	2	Bottom cover	Cast iron EN-GJL-250	DIN: GG25 ASTM: A48 class 40B BS: 1452 Grade 250
5	1	Upper stem	SS 410	DIN: 1.4006 ASTM: AISI 410 BS: 410 S 21
4	1	Lower stem	SS 410	DIN: 1.4006 ASTM: AISI 410 BS: 410 S 21
3	1	Sleeve	Heat EPDM	
2	1	Disc	CuAl10Ni5Fe4	
1	1	Body	Ductile iron EN-GJS-400-15	DIN: GGG 40 ASTM: A536 65-45-12 BS: EN-JS1030
Pos.	Qty.	Designation	Material	

DIMENSIONS

DN		Upper flange				Valve dimensions						
mm	inch	ISO	ØD	Ø D1	n x Ø N	G	H	L	PN10*			
									Ø K	4xØ 4xM	Weight (kg)	
350	14"	F10	140	102	4 x Ø12	268	353	75,6	460	4 x Ø22	57	
400	16"	F14	197	140	4 x Ø18	321	383	97	515	4 x Ø28	93	
450	18"	F14	197	140	4 x Ø18	346	422	105	565	4 x Ø28	115	
500	20"	F14	197	140	4 x Ø18	371	484	128	620	4 x Ø28	180	
600	24"	F16	276	165	4 x Ø23	450	557	152	725	4 x Ø31	260	
700	28"	F25	300	254	8 x Ø18	520	624	163	840	4 x M27	374	
800	32"	F25	300	254	8 x Ø18	609	672	188	950	4 x M30	458	
900	36"	F25	300	254	8 x Ø18	672	720	203	1050	4 x M30	914	
1000	40"	F25	300	254	8 x Ø18	719	802	215	1160	4 x M33	1085	
1200	48"	F30	350	298	8 x Ø22	863	942	276	1380	4 x M36	1854	

DN		Gear box		
mm	inch	V	P	J
350	14"	226	300	86
400	16"	255	300	105
450	18"	255	300	105
500	20"	285	400	120
600	24"	322	400	120
700	28"	367	450	125
800	32"	367	450	125
900	36"	426	500	200
1000	40"	426	500	200
1200	48"	506	550	273

PRESSURE TEMPERATURE RATING

Maxi working pressure:

10 bar.

Maxi temperature:

-15 °C / +130 °C.

Peak temperature :

-30°C / + 150 °C.

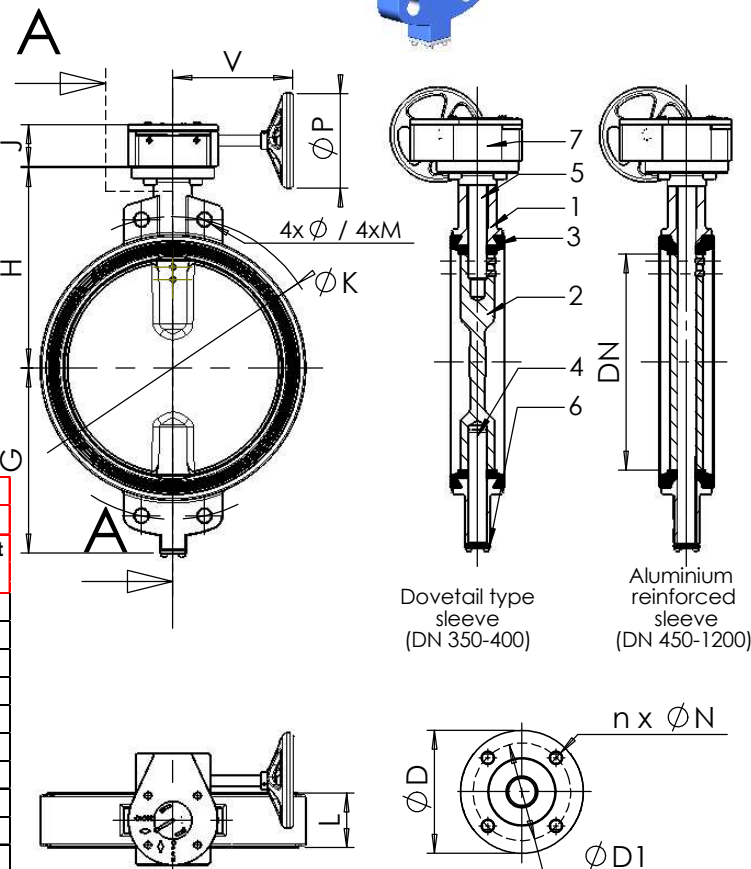

Dovetail type sleeve
(DN 350-400)

Aluminium reinforced sleeve
(DN 450-1200)

Normalized base in accordance to ISO 5211.

STANDARDS

Manufacture according to the requirements of the European directive 2014/68/UE «Equipments under pressure» : modulate H.

Pressure test according to standards EN 12266-1, DIN 3230, BS 5154 and ISO 5208 :

Body : 15,5 bar.

Seat : 11 bar.

Face to face according to standard EN 558-1 serie 20, ISO 5752 serie 20 and DIN 3202.

Wafer type ISO PN10 connections according to standard EN 1092-2.

TECOFI France - 83, Rue Marcel Mérieux 69960 Corbas - FRANCE
Tél. +33 (0) 4 72 79 05 79 - Fax +33 (0) 4 78 90 19 19 / +33 (0) 4 72 79 05 70
Adresses e-mail : sales@tecofi.fr ; tecofi@tecofi.fr / Site web : www.tecofi.fr