

KNIFE GATE VALVE STAINLESS STEEL BODY

TECHNICAL PASSPORT

KNIFE GATE VALVE - RISING STEM WITH ELECTRIC ACTUATOR AUMA STAINLESS STEEL BODY - BETWEEN FLANGES PN10

VG 6400-UX4

APPLICATION

The knife gate valve is particularly suitable for the most difficult applications.

Area of use: water treatment networks, pulp and paper industry, chemical plants, winemaking, cement works, pneumatic transport, storage.



Fluids: water, sewage, pulp, pasty products, powdery, granular, fibrous, abrasive and crystallizing.

GENERAL CHARACTERISTICS

Range: DN50 to DN600.

- Knife Gate Valve on/off or regulation with rising stem.
- Molded monobloc body
- Unidirectional water tightness: Flow direction indicated on the body with an arrow.
- Installation between flanges ISO PN10.
- Small retention zone.
- Gate with a beveled cutting edge guided in the body with little backlash.
- Guaranteed closure, without risk of blockage.
- Standard polished gate, soft contact with the gaskets.
- Very resistant stainless steel packing flange avoids risks of breaks.
- Operating force reduced thanks to the elasticity of the gaskets.
- Pre-formed profiled sheet metal support plates from DN50 to DN300 for accessory or kit mounting.
- Full flow when fully opened, ensuring a high flow rate with low head loss.
- Flow regulation possible for pasty or abrasive fluids with installation of a deflector.

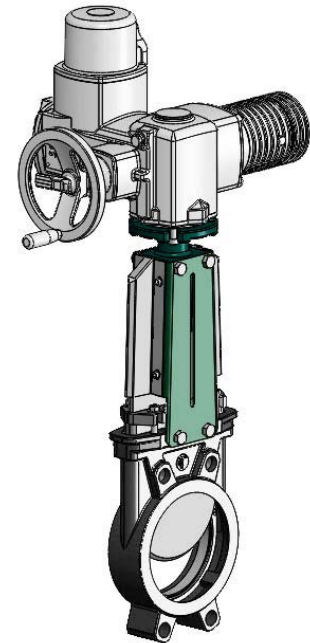

References	Actuator types
VG 6400-U04	AUMA 400V 3PH
VG 6400-B24	AUMA 230V 1PH

STANDARDS

Design	Manufacture according to the requirements of the European directive n° 2014/68/UE «Equipment under pressure» : modulate H.					
	In option: product conform to European directive ATEX «ATmosphère EXplosive» n° 2014/34/UE.					
Face to face	Face to face dimension according to TECOFI standard					
Connection	Mounting between flanges in accordance with EN1092-2 and ISO 7005-1 : ISO PN10					
Tests	Pressure test according to standards EN12266-1, DIN 3230, BS 5154 and ISO 5208.					
	DN	Body	Seat	DN	Body	Seat
	DN50-250 :	15.4 bar	11 bar	DN300-450:	12.6 bar	7.7 bar
	DN500-600:	7.2 bar	4.4 bar			

PRODUCT APPROVALS



Tecofi France

83 rue Marcel Mérieux - 69960 Corbas
Tél. +33 (0)4 72 79 05 79 - Fax. +33 (0)4 78 90 19 19
E-mail : sales@tecofi.fr - www.tecofi.fr



KNIFE GATE VALVE STAINLESS STEEL BODY

TECHNICAL PASSPORT

VG 6400-UX4

CONSTRUCTION

Coatings applied on the valve :

Component	Coating
Support plate (8)	Liquid epoxy RAL 6005 70 microns
ISO plate (23)	

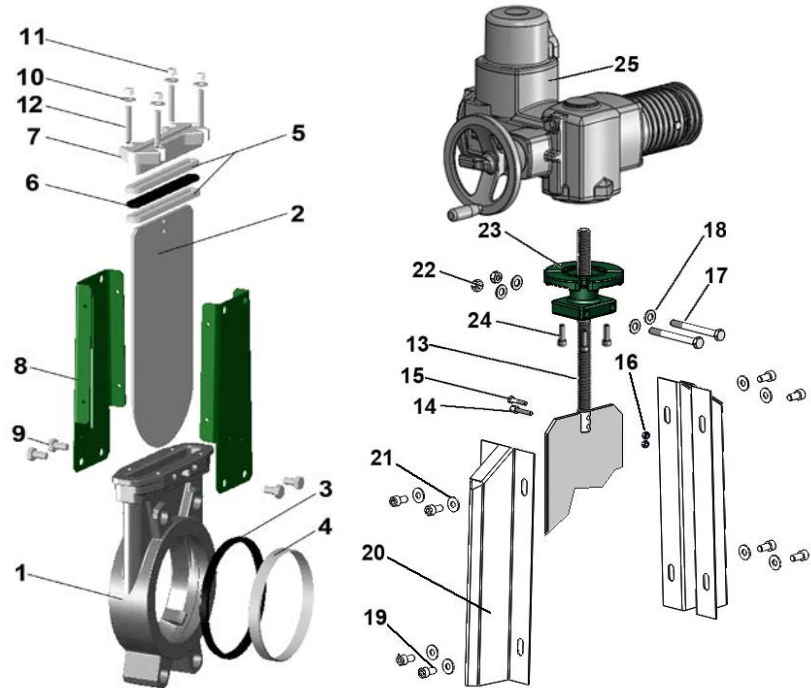

Pos.	Q-ty	Description	Material	Equivalence		
				DIN	ASTM	BS
1	1	Body	Stainless steel GX5CrNiMo 19-11-2	G-X6CrNiMo18 10	A 351 grade CF8M	316 C16
2	1	Gate	Stainless steel X2CrNi 17-12-2	X2CrNiMo17-13-2	A 182 AISI 316L	1449-2 316 S11
3	1	Seat gasket (1)	NBR			
4	1	Support ring (1)	Stainless steel X5CrNi 18 10	X5CrNiMo18 10	A 182 AISI 316	1449-2 316 S16
5	2	Packing	PTFE			
6	1	O-Ring	NBR			
7	1	Packing gland	Stainless steel GX5CrNiMo 19-11-2	G-X6CrNiMo18 10	A 351 grade CF8M	316 C16
8	2	Support plate	Steel			
9	4**	Screw	Stainless steel A2-70			
10	4*	Washer	Stainless steel A2-70			
11	4*	Nut	Stainless steel A2-70			
12	4*	Tie rod	Stainless steel A2-70			
13	1	Stem	Stainless steel 13% Cr	X12CR13	AISI 410	
14	1	Detection screw	Stainless steel X5CrNi 18 10	X5CrNi 18 10	A 182 AISI 304	1449-2 304 S15
15	1	Screw	Stainless steel A2-70			
16	2	Nut	Stainless steel X5CrNi 18 10	X5CrNi 18 10	A 182 AISI 304	1449-2 304 S15
17	2	Screw	Stainless steel A2-70			
18	4	Washer	Stainless steel A2-70			
19	8	Screw	Stainless steel A2-70			
20	2	Protection cap	Stainless steel X5CrNi 18 10	X5CrNi 18 10	A 182 AISI 304	1449-2 304 S15
21	8	Washer	Stainless steel A2-70			
22	2	Nut	Stainless steel A2-70			
23	1	ISO 5210 plate	Steel A45			
24	4	Screw	Stainless steel A2-70			
25	1	Electric actuator	AUMA model			

* - 8 for DN350-400; ** - 12 for DN450-600 (1) - Parts missing on valves with metal/metal sealing

Tecofi France

83 rue Marcel Mérieux - 69960 Corbas
Tél. +33 (0)4 72 79 05 79 - Fax. +33 (0)4 78 90 19 19
E-mail : sales@tecofi.fr - www.tecofi.fr



KNIFE GATE VALVE STAINLESS STEEL BODY

TECHNICAL PASSPORT

VG 6400-UX4

DIMENSIONS

DN		Type moteur	A	B	C	D	M	M1	N	ØV	H	Weight (kg)
mm	inch											
50	2"	SA07.2	40	383	124	83	249	265	237	160	578	27
65	2 1/2"	SA07.2	40	408	139	83	249	265	237	160	603	29
80	3"	SA07.2	50	433	154	83	249	265	237	160	628	30
100	4"	SA07.2	50	478	174	83	249	265	237	160	673	31
125	5"	SA07.6	50	516	189	93	249	265	237	160	711	38
150	6"	SA07.6	60	567	220	93	249	265	237	160	762	42
200	8"	SA07.6	60	686	275	108	249	265	237	160	881	57
250	10"	SA07.6	70	778	326	108	249	265	237	160	973	75
300	12"	SA10.2	70	887	380	108	254	282	247	200	1082	87
350	14"	SA10.2	96	990	438	290	254	282	247	200	1185	137
400	16"	SA10.2	100	1100	494	290	254	282	247	200	1295	167
450	18"	SA14.2	106	1225	547	290	329	384	285	315	1430	231
500	20"	SA14.2	110	1335	613	290	329	384	285	315	1540	266
600	24"	SA14.2	110	1539	716	290	329	384	285	315	1744	310

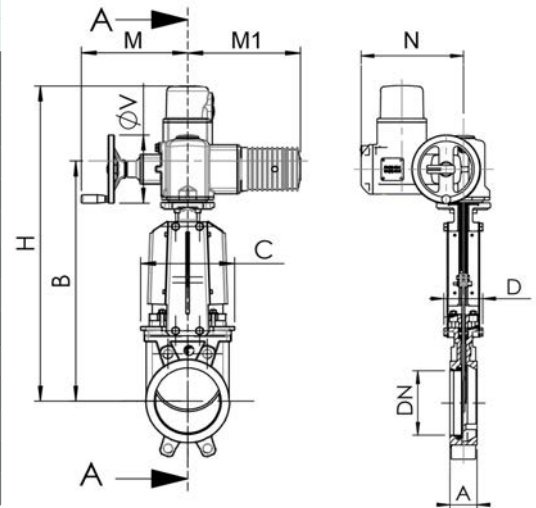

Dimension A - face to face according to TECOFI standard

MOUNTING

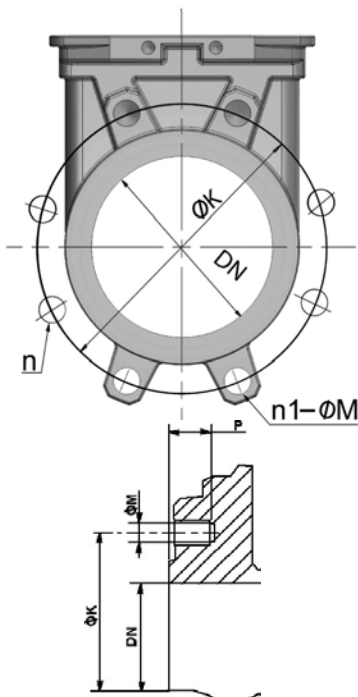

Body details

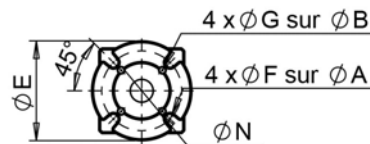

ISO plate

DN		Maximum pressure (bar)	n	n1-ØM	P	ØK	ISO plate	ØA	ØB	ØE	ØF	ØG	ØN
mm	inch												
50	2"	10	4	4xM16	8	125	F07/F10	70	102	125	9	11	70
65	2 1/2"	10	4	4xM16	8	145	F07/F10	70	102	125	9	11	70
80	3"	10	8	4xM16	9	160	F07/F10	70	102	125	9	11	70
100	4"	10	8	4xM16	9	180	F07/F10	70	102	125	9	11	70
125	5"	10	8	4xM16	9	210	F07/F10	70	102	125	9	11	70
150	6"	10	8	4XM20	10	240	F07/F10	70	102	125	9	11	70
200	8"	10	8	4XM20	12	295	F10	102	-	125	12	-	70
250	10"	10	12	8XM20	12	350	F10	102	-	125	12	-	70
300	12"	7	12	8XM20	19	400	F10	102	-	125	12	-	70
350	14"	7	16	10XM20	20	460	F10/F14	102	140	175	11	17	100
400	16"	7	16	10XM24	24	515	F10/F14	102	140	175	11	17	100
450	18"	7	20	14XM24	24	565	F10/F14	102	140	175	11	17	100
500	20"	4	20	14XM24	24	620	F10/F14	102	140	175	11	17	100
600	24"	4	20	14XM27	24	725	F10/F14	102	140	175	11	17	100

n- Total number of holes

n1- number of threaded holes

Tecofi France

83 rue Marcel Mérieux - 69960 Corbas

Tél. +33 (0)4 72 79 05 79 - Fax. +33 (0)4 78 90 19 19

E-mail : sales@tecofi.fr - www.tecofi.fr



KNIFE GATE VALVE STAINLESS STEEL BODY

TECHNICAL PASSPORT

VG 6400-UX4

WORKING CONDITIONS

Maximum working pressure : DN50-250 : 10 bar
 DN300-450 : 7 bar
 DN500-600 : 4 bar

Maximum working temperature : -10°C / +130°C (EPDM joint in standard)

▲ The above mentioned pressures are only valid if the direction of assembly indicated by the arrow on the valves is observed.

Upstream/downstream tightness

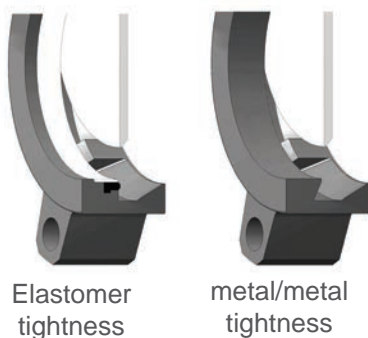

Packing tightness

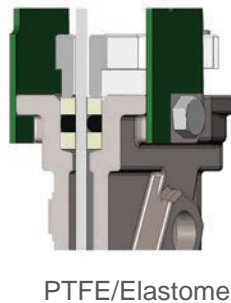

Tightness in option

Tightness	Maximum temperature
Metal/metal	Tmax : -10°C / +80°C
NBR	Tmax : -10°C / +80°C
White EPDM	Tmax : -10°C / +130°C
Silicone	Tmax : -10°C / +170°C
FPM (Type Viton®)	Tmax : -10°C / +170°C
PTFE	Tmax : +4°C / +170°C
CSM (Type Hypalon®)	Tmax : +4°C / +80°C

▲ To ensure a satisfactory tightness, when using the PTFE gasket, the operating pressure must be at least 1 bar.

FLOWS

Flow rates of valves under different differential pressure (m³/h)

DN		0.2 bar	0.4 bar	0.6 bar	0.8 bar	1.0 bar
mm	inch					
50	2"	93	134	165	185	206
65	2 1/2"	129	180	213	268	309
80	3"	191	309	371	422	494
100	4"	443	618	721	824	927
125	5"	700	927	1133	1339	1545
150	6"	927	1339	1545	1906	2060
200	8"	1597	2369	2987	3399	4017
250	10"	2472	3502	4429	5150	5665
300	12"	4120	5665	6798	7828	8755
350	14"	5335	7372	8730	9700	11640
400	16"	6693	9312	11640	13580	15520
450	18"	8342	12610	14550	16490	18430
500	20"	9700	14550	17460	19400	22310
600	24"	14550	19400	25220	29100	33950

The column of the table under 1 bar gives the values of the Kvs of the valves.

Tecofi France

83 rue Marcel Mérieux - 69960 Corbas
 Tél. +33 (0)4 72 79 05 79 - Fax. +33 (0)4 78 90 19 19
 E-mail : sales@tecofi.fr - www.tecofi.fr

