

KNIFE GATE VALVE STAINLESS STEEL IRON BODY

TECHNICAL PASSPORT

KNIFE GATE VALVE WITH LEVER STAINLESS STEEL BODY - BETWEEN FLANGES PN10

VG 6400-02

APPLICATION

The knife gate valve is particularly suitable for the most difficult applications.

Area of use: water treatment networks, pulp and paper industry, chemical plants, winemaking, cement works, pneumatic transport, storage.



Fluids: water, sewage, pulp, pasty products, powdery, granular, fibrous, abrasive and crystallizing.

GENERAL CHARACTERISTICS

Range: DN50 to DN300.

- Knife Gate Valve on/off or regulation with rising stem.
- Molded monobloc body
- Unidirectional water tightness: Flow direction indicated on the body with an arrow.
- Installation between flanges ISO PN10.
- Small retention zone.
- Gate with a beveled cutting edge guided in the body with little backlash.
- Guaranteed closure, without risk of blockage.
- Standard polished gate, soft contact with the gaskets.
- Very resistant stainless steel packing flange avoids risks of breaks.
- Operating force reduced thanks to the elasticity of the gaskets.
- Pre-formed profiled sheet metal support plates from DN50 to DN300 for accessory or kit mounting.
- Full flow when fully opened, ensuring a high flow rate with low head loss.
- Flow regulation possible for pasty or abrasive fluids with installation of a deflector.

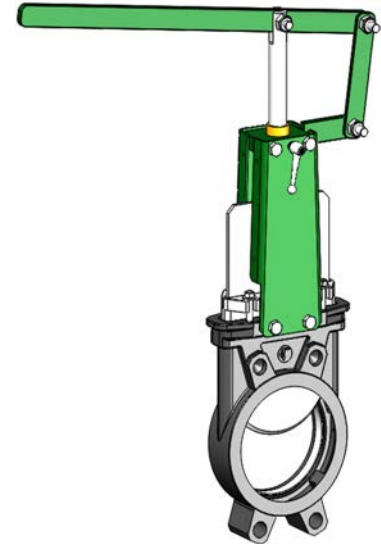

STANDARDS

Design	Manufacture according to the requirements of the European directive n° 2014/68/UE «Equipment under pressure» : modulate H.					
	In option: product conform to European directive ATEX «ATmosphère EXplosive» n° 2014/34/UE.					
Face to face	Face to face dimension according to TECOFI standard					
Connection	Mounting between flanges in accordance with EN1092-2 and ISO 7005-1: ISO PN10					
Tests	Pressure test according to standards EN12266-1, DIN 3230, BS 5154 and ISO 5208.					
	DN	Body	Seat	DN	Body	Seat
	DN50-250 :	15.4 bar	11 bar	DN300:	12.6 bar	7.7 bar

PRODUCT APPROVALS



Tecofi France

83 rue Marcel Mérieux - 69960 Corbas
Tél. +33 (0)4 72 79 05 79 - Fax. +33 (0)4 78 90 19 19
E-mail : sales@tecofi.fr - www.tecofi.fr

KNIFE GATE VALVE STAINLESS STEEL IRON BODY

TECHNICAL PASSPORT

VG 6400-02

CONSTRUCTION

Coatings applied on the valve :

Constituant	Revêtement
Support plate (8)	Liquid epoxy RAL 6005 70 microns
Lever (19)	

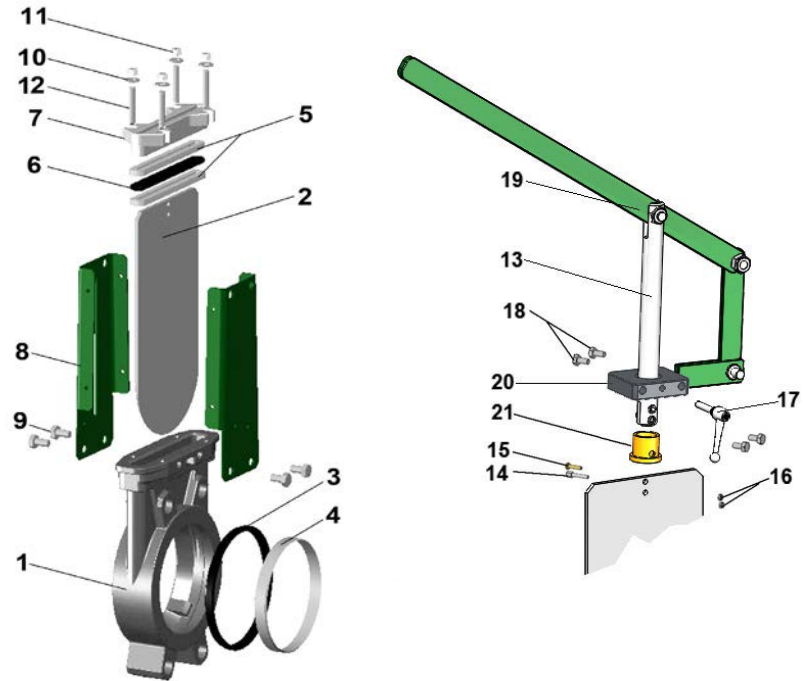

Pos.	Q-ty	Description	Material	Equivalences		
				DIN	ASTM	BS
1	1	Body	Stainless steel GX5CrNiMo 19-11-2	G-X6CrNiMo18 10	A 351 grade CF8M	316 C16
2	1	Gate	Stainless steel X2CrNi 17-12-2	X2CrNiMo17-13-2	A 182 AISI 316L	1449-2 316 S11
3	1	Seat gasket (1)	EPDM			
4	1	Support ring (1)	Stainless steel X5CrNiMo 17-12-2	X5CrNiMo18 10	A 182 AISI 316	1449-2 316 S16
5	2	Packing	PTFE			
6	1	O-Ring	EPDM			
7	1	Packing gland	Stainless steel GX5CrNiMo 19-11-2	G-X6CrNiMo18 10	A 351 grade CF8M	316 C16
8	2	Support plate	Steel			
9	4	Screw	Stainless steel A2-70			
10	4	Washer	Stainless steel A2-70			
11	4	Nut	Stainless steel A2-70			
12	4	Tie rod	Stainless steel A2-70			
13	1	Stem	Stainless steel 13% Cr	X12CR13	AISI 410	
14	1	Screw	Stainless steel X5CrNi 18 10	X5CrNi 18 10	A 182 AISI 304	1449-2 304 S15
15	1	Screw	Stainless steel A2-70			
16	2	Nut	Stainless steel X5CrNi 18 10	X5CrNi 18 10	A 182 AISI 304	1449-2 304 S15
17	1	Stop screw	Painted steel			
18	4	Screw	Stainless steel A2-70			
19	1	Lever	Steel			
20	1	Support nut	Zinc plated steel			
21	1	Support washer	Bronze CuSn5Zn8Pb5-C			

(1) - Parts missing on valve with metal/metal sealing

Tecofi France

83 rue Marcel Mérieux - 69960 Corbas
Tél. +33 (0)4 72 79 05 79 - Fax. +33 (0)4 78 90 19 19
E-mail : sales@tecofi.fr - www.tecofi.fr



KNIFE GATE VALVE STAINLESS STEEL IRON BODY

TECHNICAL PASSPORT

VG 6400-02

DIMENSIONS

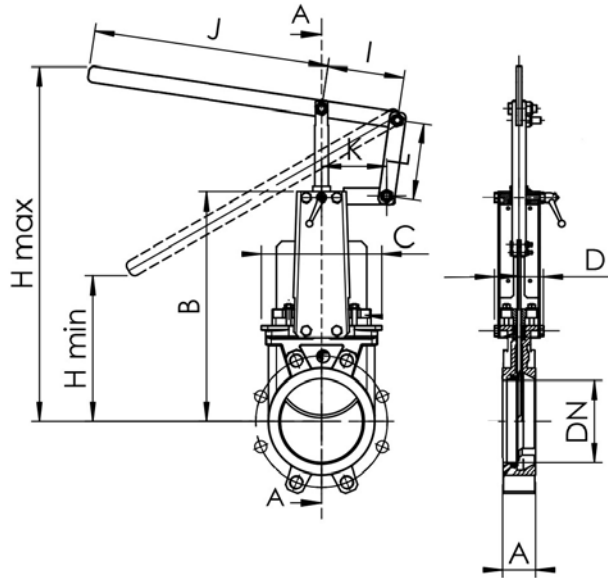

DN		A	B	C	D	Hmin	Hmax	I	J	K	L	Weight (kg)
mm	inch											
50	2"	40	240	124	83	93	329	140	330	119	140	7.5
65	2"1/2"	40	265	139	83	119	407	140	330	119	140	7.8
80	3"	50	290	154	83	226	563	140	330	119	140	8.4
100	4"	50	335	174	83	147	631	140	430	119	140	11.5
125	5"	50	373	189	93	187	767	140	430	119	140	14.4
150	6"	60	424	220	93	236	918	140	430	119	140	18.5
200	8"	60	533	275	108	183	1058	228	638	173	255	28.8
250	10"	70	625	326	108	205	1501	220	845	203	255	41.0
300	12"	70	732	380	108	287	1635	250	815	230	300	58.0

Dimension A - face to face according to TECOFI standard

MOUNTING

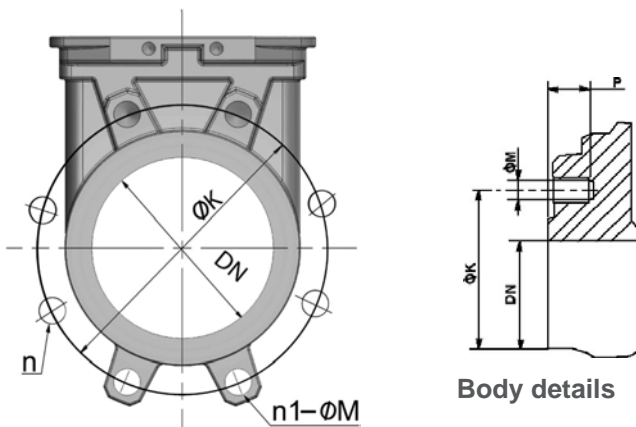

Body details

DN		Maximum pressure (bar)	n	n1-ØM	P	ØK
mm	inch					
50	2"	10	4	4xM16	8	125
65	2"1/2"	10	4	4xM16	8	145
80	3"	10	8	4xM16	9	160
100	4"	10	8	4xM16	9	180
125	5"	10	8	4xM16	9	210
150	6"	10	8	4XM20	10	240
200	8"	10	8	4XM20	12	295
250	10"	10	12	8XM20	12	350
300	12"	7	12	8XM20	19	400

n- total number of holes
n1- number of threaded holes

Tecofi France

83 rue Marcel Mérieux - 69960 Corbas

Tél. +33 (0)4 72 79 05 79 - Fax. +33 (0)4 78 90 19 19

E-mail : sales@tecofi.fr - www.tecofi.fr



KNIFE GATE VALVE STAINLESS STEEL IRON BODY

TECHNICAL PASSPORT

VG 6400-02

WORKING CONDITIONS

Maximum working pressure: DN50-250 : 10 bar
DN 300 : 7 bar

Maximum working temperature : -10°C / +130°C (EPDM Joint in standard)

⚠ The above mentioned pressures are only valid if the direction of assembly indicated by the arrow on the valves is observed.

Upstream/downstream tightness

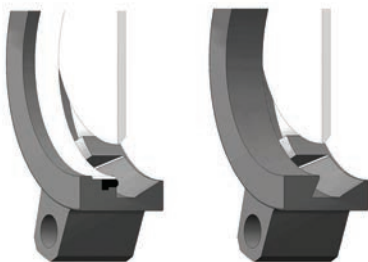

Elastomer tightness

Metal/metal tightness

Packing tightness

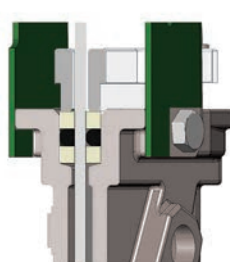

PTFE/Elastomer

Tightness in option

Tightness	Maximum temperature
Metal/metal	Tmax : -10°C / +130°C
NBR	Tmax : -10°C / +80°C
White EPDM	Tmax : -10°C / +130°C
Silicone	Tmax : -10°C / +170°C
FPM (Type Viton®)	Tmax : -10°C / +170°C
PTFE	Tmax : +4°C / +170°C

CSM (Type Hypalon®) Tmax : +4°C / +80°C

⚠ To ensure a satisfactory tightness, when using the PTFE gasket, the operating pressure must be at least 1 bar.

FLOWS

Flow rates of valves under different differential pressure (m³/h)

DN		0.2 bar	0.4 bar	0.6 bar	0.8 bar	1.0 bar
mm	inch					
50	2"	93	134	165	185	206
65	2 1/2"	129	180	213	268	309
80	3"	191	309	371	422	494
100	4"	443	618	721	824	927
125	5"	700	927	1133	1339	1545
150	6"	927	1339	1545	1906	2060
200	8"	1597	2369	2987	3399	4017
250	10"	2472	3502	4429	5150	5665
300	12"	4120	5665	6798	7828	8755

The column of the table under 1 bar gives the values of the Kvs of the valves.

Tecofi France

83 rue Marcel Mérieux - 69960 Corbas
Tél. +33 (0)4 72 79 05 79 - Fax. +33 (0)4 78 90 19 19
E-mail : sales@tecofi.fr - www.tecofi.fr

