

KNIFE GATE VALVE STAINLESS STEEL BODY

TECHNICAL PASSPORT

KNIFE GATE VALVE WITH HANDWHEEL RISING STEM STAINLESS STEEL BODY - WAFER TYPE PN10

VG 6400-00EA

APPLICATION

The knife gate valve is particularly suitable for the most difficult applications.

Area of use: water distribution



Fluids: drinking water.

GENERAL CHARACTERISTICS

Range: from DN50 to DN600.

- Knife Gate Valve on/off or regulation with rising stem.
- Molded monobloc body
- Unidirectional water tightness: Flow direction indicated on the body with an arrow.
- Installation between flanges ISO PN10.
- Small retention zone.
- Gate with a beveled cutting edge guided in the body with little backlash.
- Guaranteed closure, without risk of blockage.
- Standard polished gate, soft contact with the gaskets.
- Very resistant stainless steel packing flange avoids risks of breaks.
- Operating force reduced thanks to the elasticity of the gaskets.
- Pre-formed profiled sheet metal support plates from DN50 to DN300 for accessory or kit mounting.
- Full flow when fully opened, ensuring a high flow rate with low head loss.
- Flow regulation possible for pasty or abrasive fluids with installation of a deflector.



ACS

STANDARDS

Design	Manufacture according to the requirements of the European directive n° 2014/68/UE «Equipment under pressure» : modulate H.					
	In option: product conform to European directive ATEX «ATmosphère EXplosive» n° 2014/34/UE.					
Face to face	Face to face dimension according to TECOFI standard					
Connection	Mounting between flanges in accordance with EN1092-2 and ISO 7005-1 : ISO PN10					
Tests	Pressure test according to standards EN12266-1, DIN 3230, BS 5154 and ISO 5208.					
	DN	Body	Seat	DN	Body	Seat
	DN50-250 :	15.4 bar	11 bar	DN300-450:	12.6 bar	7.7 bar
	DN500-600:	7.2 bar	4.4 bar			

PRODUCT APPROVALS



On request



Attestation of health conformity n° 20 ACC LY 445

Tecofi France

83 rue Marcel Mérieux - 69960 Corbas
Tél. +33 (0)4 72 79 05 79 - Fax. +33 (0)4 78 90 19 19
E-mail : sales@tecofi.fr - www.tecofi.fr



KNIFE GATE VALVE STAINLESS STEEL BODY

TECHNICAL PASSPORT

VG 6400-00EA

CONSTRUCTION

Coatings applied on the valve :

Component	Coating
Support plate (8)	Liquid epoxy RAL 6005 70 microns
Handwheel (23)	Liquid epoxy RAL 9005 70 microns
Protection tube (24)	

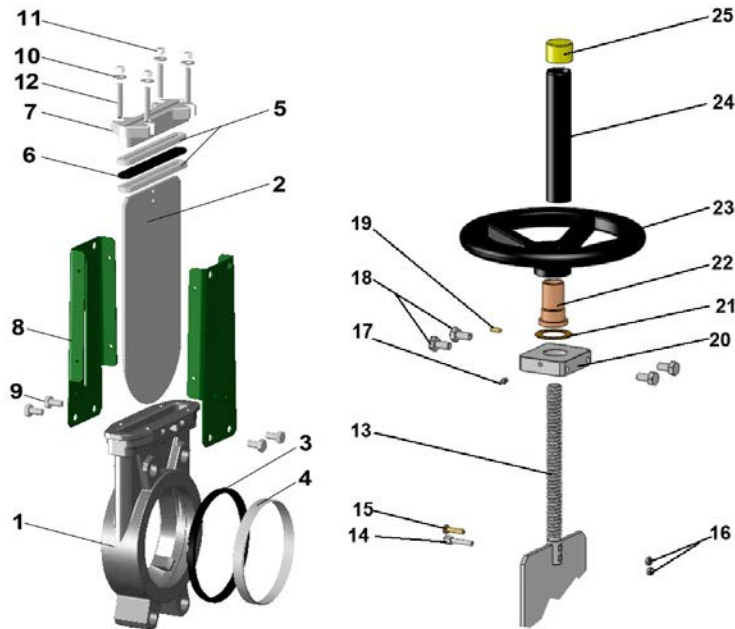

Pos.	Q-ty	Description	Material	Equivalences		
				DIN	ASTM	BS
1	1	Body	Stainless steel GX5CrNiMo 19-11-2	G-X6CrNiMo18 10	A 351 grade CF8M	316 C16
2	1	Gate	Stainless steel X2CrNi 18-10	X2CrNiMo17-13-2	A 182 AISI 316L	1449-2 316 S11
3	1	Seat gasket	EPDM ACS			
4	1	Support ring	Stainless steel X5CrNi 18-10	X5CrNiMo18 10	A 182 AISI 316	1449-2 316 S16
5	2	Packing	LATTYflon 3206 AL			
6	1	O-Ring	EPDM ACS			
7	1	Packing gland	Stainless steel GX5CrNiMo 19-11-2	G-X6CrNiMo18 10	A 351 grade CF8M	316 C16
8	2	Support plate	Steel			
9	4	Screw	Stainless steel A2-70			
10	4	Washer	Stainless steel A2-70			
11	4	Nut	Stainless steel A2-70			
12	4	Tie rod	Stainless steel A2-70			
13	1	Stem	Stainless steel 13% Cr	X12Cr13	AISI 410	
14	1	Detection screw	Stainless steel X5CrNi 18-10	X5CrNi 18 10	A 182 AISI 304	1449-2 304 S15
15	1	Screw	Stainless steel A2-70			
16	2	Nut	Stainless steel X5CrNi 18-10	X5CrNi 18 10	A 182 AISI 304	1449-2 304 S15
17	1	Greaser	Stainless steel X5CrNi 18-10	X5CrNi 18 10	A 182 AISI 304	1449-2 304 S15
18	4	Screw	Stainless steel A2-70			
19	1	Screw	Stainless steel A2-70			
20	1	Nut support	Zinc plated steel			
21	1	Support washer	Bronze CuSn5Zn8Pb5-C			
22	1	Nut	Bronze CuSn5Zn8Pb5-C			
23	1	Handwheel	Cast iron EN-GJL-250	GG25	A48 class 40B	1452 Grade 250
24	1	Protection tube	Steel A45			
25	1	Plug	Polyurethane			

Tecofi France

83 rue Marcel Mérieux - 69960 Corbas

Tél. +33 (0)4 72 79 05 79 - Fax. +33 (0)4 78 90 19 19

E-mail : sales@tecofi.fr - www.tecofi.fr



KNIFE GATE VALVE STAINLESS STEEL BODY

TECHNICAL PASSPORT

VG 6400-00EA

CONSTRUCTION

Coatings applied on the valve :

Component	Coating
Support plate (8)	Liquid epoxy RAL 6005 70 microns
Handwheel (23)	Liquid epoxy RAL 9005 70 microns
Protection tube (24)	Liquid epoxy RAL 9005 70 microns

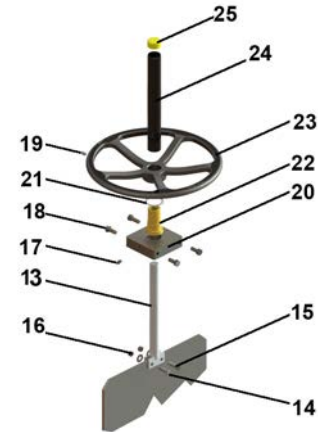
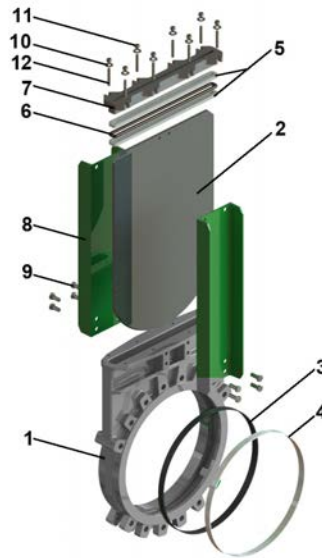

Pos.	Q-ty	Description	Material	Equivalences		
				DIN	ASTM	BS
1	1	Body	Stainless steel GX5CrNiMo 19-11-2	G-X6CrNiMo18 10	A 351 grade CF8M	316 C16
2	1	Gate	Stainless steel X2CrNi 18-10	X2CrNiMo17-13-2	A 182 AISI 316L	1449-2 316 S11
3	1	Seat gasket	EPDM ACS			
4	1	Support ring	Stainless steel X5CrNiMo 17-12-2	X5CrNiMo18 10	A 182 AISI 316	1449-2 316 S16
5	2	Packing	LATTYflon 3206 AL			
6	1	O-Ring	EPDM ACS			
7	1	Packing gland	Stainless steel GX5CrNiMo 19-11-2	G-X6CrNiMo18 10	A 351 grade CF8M	316 C16
8	2	Support plate	Steel			
9	12**	Screw	Stainless steel A2-70			
10	8*	Washer	Stainless steel A2-70			
11	8*	Nut	Stainless steel A2-70			
12	8*	Tie rod	Stainless steel A2-70			
13	1	Stem	Stainless steel 13% Cr	X12Cr13	AISI 410	
14	1	Detection screw	Stainless steel X5CrNi 18-10	X5CrNi 18 10	A 182 AISI 304	1449-2 304 S15
15	1	Screw	Stainless steel A2-70			
16	2	Nut	Stainless steel X5CrNi 18-10	X5CrNi 18 10	A 182 AISI 304	1449-2 304 S15
17	1	Greaser	Stainless steel X5CrNi 18-10	X5CrNi 18 10	A 182 AISI 304	1449-2 304 S15
18	4	Screw	Stainless steel A2-70			
19	1	Screw	Stainless steel A2-70			
20	1	Nut support	Zinc plated steel			
21	1	Support washer	Bronze CuSn5Zn8Pb5-C			
22	1	Nut	Bronze CuSn5Zn8Pb5-C			
23	1	Handwheel	Cast iron EN-GJL-250	GG25	A48 class 40B	1452 Grade 250
24	1	Protection tube	Steel A45			
25	1	Plug	Polyurethane			

* - 8 for DN350-400; ** - 12 for DN450-600

Tecofi France

83 rue Marcel Mérieux - 69960 Corbas
Tél. +33 (0)4 72 79 05 79 - Fax. +33 (0)4 78 90 19 19
E-mail : sales@tecofi.fr - www.tecofi.fr



KNIFE GATE VALVE STAINLESS STEEL BODY

TECHNICAL PASSPORT

VG 6400-00EA

DIMENSIONS

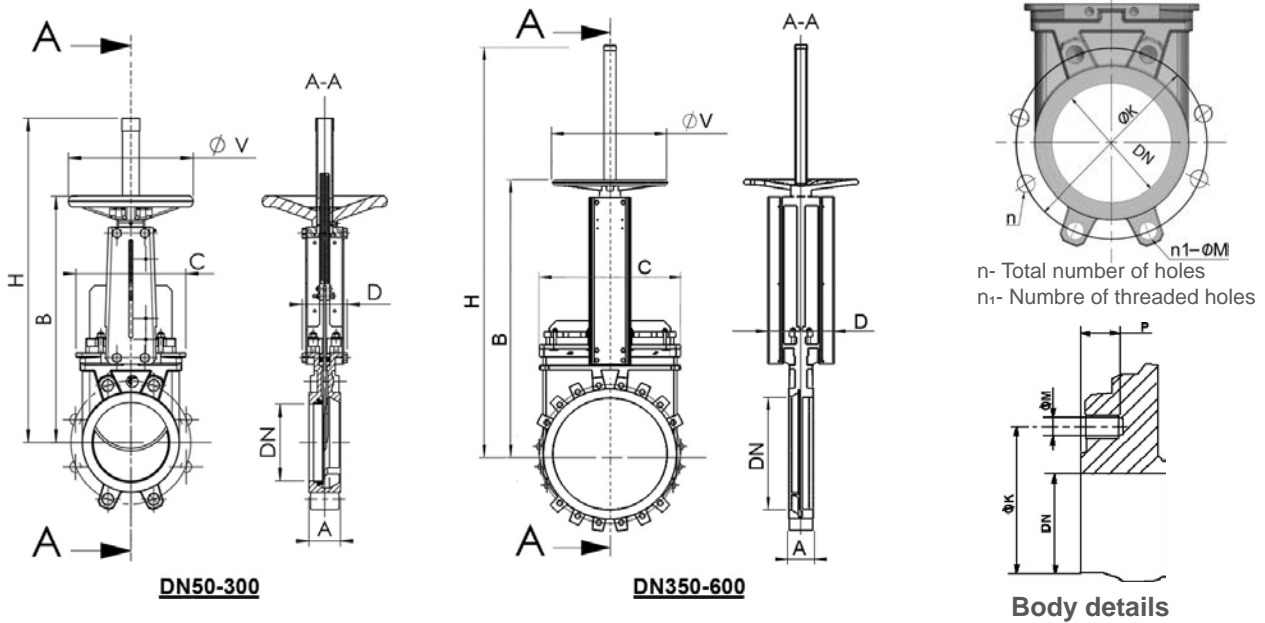

MOUNTING DIMENSIONS

DN		A	B	C	D	Ø V	H	Maximum pressure (bar)	n	n-ØM	P	ØK	Weight (kg)
mm	inch												
50	2"	40	283	124	83	200	348	10	4	4xM16	8	125	7,5
65	2 1/2"	40	308	139	83	200	388	10	4	4xM16	8	145	9
80	3"	50	333	154	83	200	413	10	8	4xM16	9	160	10
100	4"	50	378	174	83	200	488	10	8	4xM16	9	180	11,5
125	5"	50	423	189	93	250	564	10	8	4xM16	9	210	15,5
150	6"	60	474	220	93	250	635	10	8	4xM20	10	240	18,5
200	8"	60	593	275	108	310	809	10	8	4xM20	12	295	35
250	10"	70	685	326	108	310	946	10	12	8xM20	12	350	47
300	12"	70	792	380	108	310	1118	7	12	8xM20	19	400	61
350	14"	96	900	438	290	500	1282	7	16	10xM20	20	460	117
400	16"	100	978	494	290	500	1441	7	16	10xM24	24	515	151
450	18"	106	1105	547	290	500	1587	7	20	14xM24	24	565	187
500	20"	110	1215	613	290	500	1809	4	20	14xM24	24	620	205
600	24"	110	1418	716	290	500	2060	4	20	14xM27	24	725	292

Face to face dimension «A» in accordance with TECOFI standard

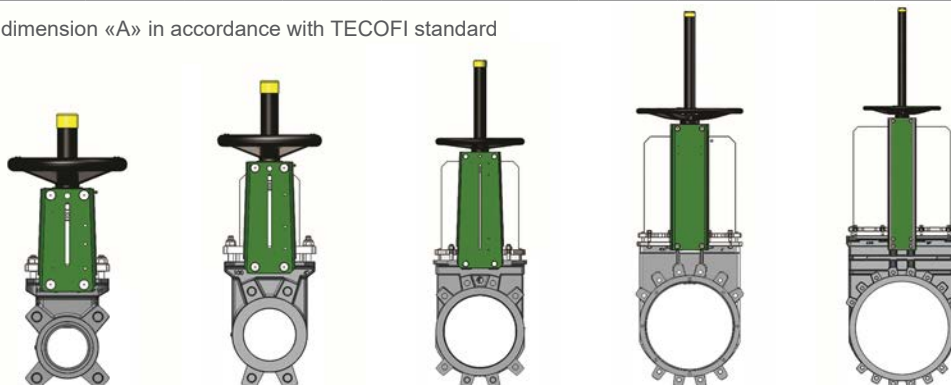

Tecofi France

83 rue Marcel Mérieux - 69960 Corbas

Tél. +33 (0)4 72 79 05 79 - Fax. +33 (0)4 78 90 19 19

E-mail : sales@tecofi.fr - www.tecofi.fr

ISO 9001
ISO 14001
BUREAU VERITAS
Certification



KNIFE GATE VALVE STAINLESS STEEL BODY

TECHNICAL PASSPORT

VG 6400-00EA

WORKING CONDITIONS

Maximum working pressure: DN50-250 : 10 bar
 DN300-450 : 7 bar
 DN500-600 : 4 bar

Maximum working temperature : -10°C / +90°C

⚠ The above mentioned pressures are only valid if the direction of assembly indicated by the arrow on the valves is observed.

Upstream/downstream tightness



Packing tightness

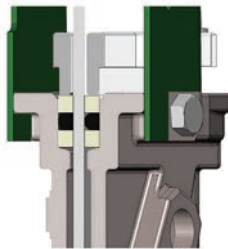

FLOWS

Flow rates of valves under different differential pressure (m³/h)

DN		0.2 bar	0.4 bar	0.6 bar	0.8 bar	1.0 bar
mm	inch					
50	2"	93	134	165	185	206
65	2 1/2"	129	180	213	268	309
80	3"	191	309	371	422	494
100	4"	443	618	721	824	927
125	5"	700	927	1133	1339	1545
150	6"	927	1339	1545	1906	2060
200	8"	1597	2369	2987	3399	4017
250	10"	2472	3502	4429	5150	5665
300	12"	4120	5665	6798	7828	8755
350	14"	5335	7372	8730	9700	11640
400	16"	6693	9312	11640	13580	15520
450	18"	8342	12610	14550	16490	18430
500	20"	9700	14550	17460	19400	22310
600	24"	14550	19400	25220	29100	33950

The column of the table under 1 bar gives the values of the Kvs of the valves

Tecofi France

83 rue Marcel Mérieux - 69960 Corbas
 Tél. +33 (0)4 72 79 05 79 - Fax. +33 (0)4 78 90 19 19
 E-mail : sales@tecofi.fr - www.tecofi.fr

