

KNIFE GATE VALVE WITH HANDWHEEL

VG 6400-001



APPLICATION

General use : Pulp production, water, water treatment, waste water, chemical industry (powdery or crystallizing products), wine-producing, pulverized products (cement work, pneumatic transport, stocking).

GENERAL CHARACTERISTICS

Function ON/OFF or regulation.
 Wafer threaded mounting ISO PN10.
 Unidirectional tightness, direction indication thanks to the arrow on the body.
 Small retention zone: the gate is guided in the body and has little clearance.
 Gland assembly: packing and O-ring (same material as seat joint) to assure the elasticity and decrease the operating torque.
 Small head loss.
 Possibility to regulate thick fluids with the adaptation of a diaphragm ring .

CONSTRUCTION

14**	1	Support ring	Stainless steel 316	DIN : X5CrNiMo18 10 ASTM : A 182 AISI 316 BS : 316 S16
13	1	Handwheel	Cast iron	DIN : GG25 ASTM : A 48 class 40B BS : 1452 grade 250
12	2	Nut	Stainless steel	
11	1	Friction washer	Bronze	
10**	1	Gasket	EPDM	
9	1	O-ring	EPDM	
8	1	Packing gland	Stainless steel	
7	1	Nut	Bronze	
6	1	Nut support	Zinc steel	
5*	2	Support plate	Steel + epoxy	
4	1	Stem	Stainless steel 13%Cr	
3	1	Knife gate	X5CrNiMo 17-12-2	DIN : X5CrNiMo18 10 ASTM : A 182 AISI 316 BS : 1449-2 316 S16
2	2	Packing	PTFE	
1	1	Body	GX5CrNiMo 19-11-2	DIN : G-X5CrNiMo18 10 ASTM : A 351 grade CF8M BS : 316 C16
Pos.	Qty.	Description	Material	

* Pre-shaped parts up to DN 300.
 ** Missing parts pon metal-metal tightness.

DIMENSIONS

DN	A	B	C	D	ØV	H	ØK	n	ØM	Weight (kg)	
50	2"	40	105	124	94	200	291	125	4	4-M16	7,5
65	2 1/2"	40	115	139	94	200	318	145	4	4-M16	8,8
80	3"	50	124	154	94	200	342	160	8	4-M16	9,4
100	4"	50	140	174	94	200	383	180	8	4-M16	11,5
125	5"	50	150	189	100	250	420	210	8	4-M16	15,4
150	6"	60	175	220	101	250	471	240	8	4-M20	18,5
200	8"	60	205	275	124	310	577	295	8	4-M20	34,8
250	10"	70	250	326	126	310	677	350	12	8-M20	47,0
300	12"	70	300	380	128	310	777	400	12	8-M20	61,0
350	14"	96	339	438	290	500	939	460	16	10-M20	117,0
400	16"	100	392	494	290	500	1037	515	16	10-M24	151,0
450	18"	106	434	547	290	500	1125	565	20	14-M24	187,0
500	20"	110	487	613	290	500	1237	620	20	14-M24	205,0
600	24"	110	592	716	290	500	1432	725	20	14-M27	292,0

WORKING CONDITIONS

Maximum working pressure : DN 50-250 : 10 bar
 DN 300-450 : 7 bar
 DN 500-600 : 4 bar

Maximum temperature : -10°C / +130°C (standard tightness).

Others materials on request (If marked)	Maximum temperature	
Metal / metal	T max : -10°C / +130°C.	<input type="checkbox"/>
NBR	T max : -10°C / +80°C.	<input type="checkbox"/>
White EPDM	T max : -10°C / +130°C.	<input type="checkbox"/>
Silicone	T max : -10°C / +170°C.	<input type="checkbox"/>
FPM (Type Viton®)	T max : -10°C / +170°C.	<input type="checkbox"/>
PTFE	T max : +4°C / +170°C.	<input type="checkbox"/>
CSM (Type Hypalon®)	T max : +4°C / +80°C.	<input type="checkbox"/>

STANDARDS

Manufacture according to the requirements of the European directive 2014/68/UE «Equipments under pressure» : modulate H.
 On request : Product in accordance to european directive "Potentially explosive atmospheres" N° 94/9/EC ; ATEX II 2 GD c and ATEX II 3 GD c.
 Test procedures are established according to standard EN 12266-1, DIN 3230, BS 5154 and ISO 5208.
 Connections according to standard EN 1092-2 and DIN 2501 : ISO PN10.

TECOFI France - 83, Rue Marcel Mérieux 69960 Corbas - FRANCE
 Tél. +33 (0) 4 72 79 05 79 - Fax +33 (0) 4 78 90 19 19 / +33 (0) 4 72 79 05 70
 Adresses e-mail : sales@tecofi.fr ; tecofi@tecofi.fr / Site web : www.tecofi.fr

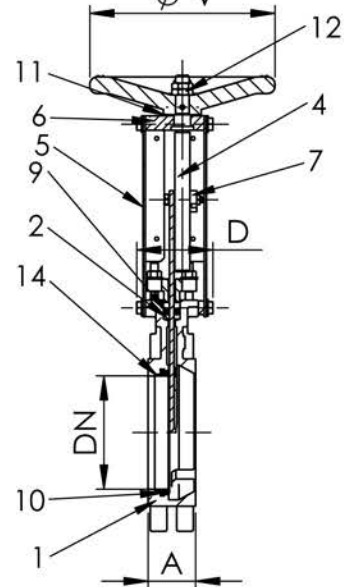
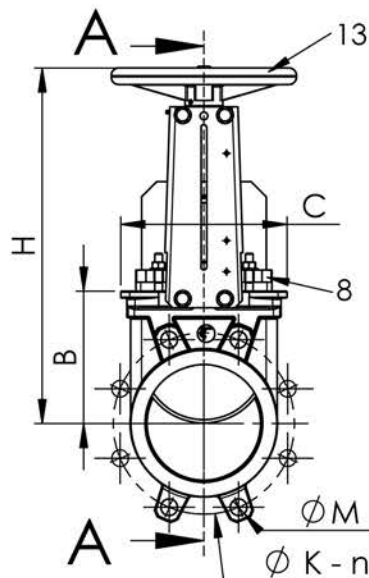
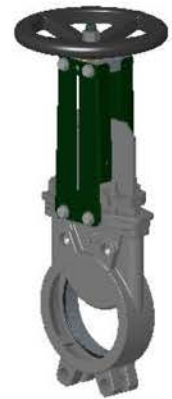

Standard tightness



Tightness metal/metal