

# FLANGED PN25 SINGLE CHAMBER AIR VALVE

TECHNICAL PASSPORT

## SINGLE CHAMBER / FOUR FUNCTION NON SLAM AIR RELEASE AND VACUUM VALVE FLANGED PN25

PVQ4250

### APPLICATION

The single chamber /four function air valve is intended for use in clear water supply systems.

It provides the following functions:

1. The evacuation of large volumes of air at start-up and filling of the piping.
2. The supply of large amounts of air to the system closure during purging of the piping.
3. Rejection of pressurized air pockets during operation.
4. Prevention of water hammer during operation and start-up of the system by forming an air pillow in the system.



Fluids : clear water, potable water.



### GENERAL CHARACTERISTICS

Range : from DN 25 to DN200.

Body consisting of a chamber containing three floats.

Large discharge and intake capacity.

Body coating : epoxy powder paint bonded by electrostatic fusion (RAL 5005, 250 microns).

### STANDARDS

Connection	Flange assembling PN25 according to EN1092-2, ISO 7005/2 , BS4504.
------------	--

### PRODUCT APPROVALS

ERC

**Tecofi France**

83 rue Marcel Mérieux - 69960 Corbas  
Tél. +33 (0)4 72 79 05 79 - Fax. +33 (0)4 78 90 19 19  
E-mail : sales@tecofi.fr - [www.tecofi.fr](http://www.tecofi.fr)



## FLANGED PN25 SINGLE CHAMBER AIR VALVE

### TECHNICAL PASSPORT

PVQ4250

#### CONSTRUCTION

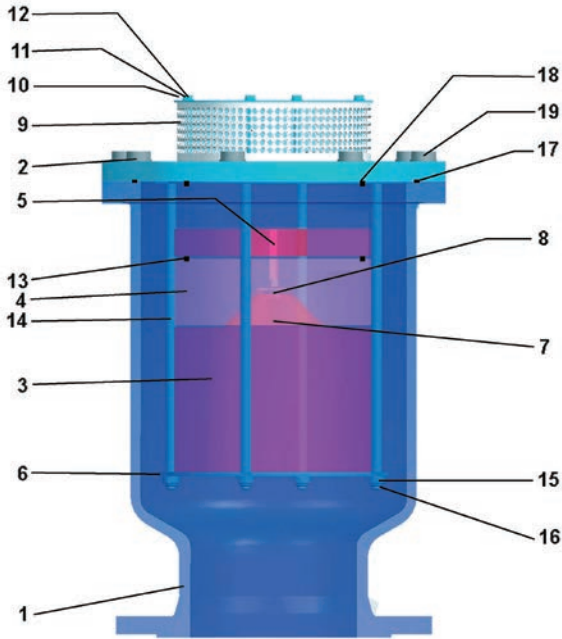

Pos.	Description	Material
1	Body	Ductile iron GGG40
2	Cover	Stainless steel AISI 304
3	Large float	Polypropylene
4	Middle float	Polypropylene
5	Top float	Polypropylene
6	Ring	Stainless steel AISI 304
7	Orifice gasket	EPDM
8	Small orifice	Polypropylene
9	Filter	Stainless steel AISI 304
10	Float cover	Stainless steel AISI 304
11	Washer	Stainless steel AISI 304
12	Screw	Stainless steel AISI 304
13	O-ring	EPDM
14	Cage	Stainless steel AISI 304
15	Nut	Stainless steel AISI 304
16	Washer	Stainless steel AISI 304
17	O-ring	EPDM
18	O-ring	EPDM
19	Bolt	Stainless steel AISI 304

#### DIMENSIONS

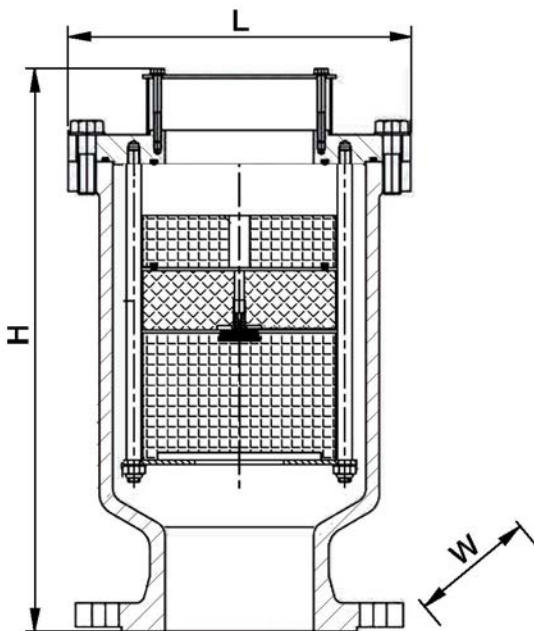

DN		L	H	W	Weight (kg)
mm	inch				
25	1"	105	205	115	8
50	2"	155	280	165	11
80	3"	200	330	200	37
100	4"	230	380	235	40
150	6"	310	490	300	43
200	8"	420	580	360	96

The photographs and technical art works are not contractual. The specifications of the presented products are open to modifications without previous advice.

**Tecofi France**

83 rue Marcel Mérieux - 69960 Corbas  
 Tél. +33 (0)4 72 79 05 79 - Fax. +33 (0)4 78 90 19 19  
 E-mail : sales@tecofi.fr - [www.tecofi.fr](http://www.tecofi.fr)



# FLANGED PN25 SINGLE CHAMBER AIR VALVE

TECHNICAL PASSPORT

PVQ4250

## WORKING CONDITIONS

Maximum working pressure : 25 bar  
Minimum working pressure : 0.2 bar  
Maximum working temperature : -10°C / +80°C

## AIR INFLOW AND OUTFLOW

### Air outflow

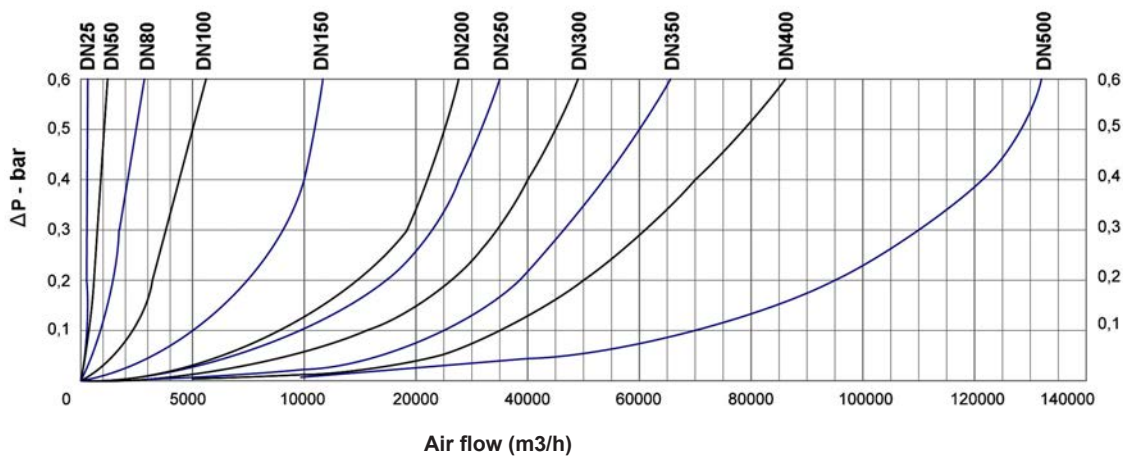

### Air inflow

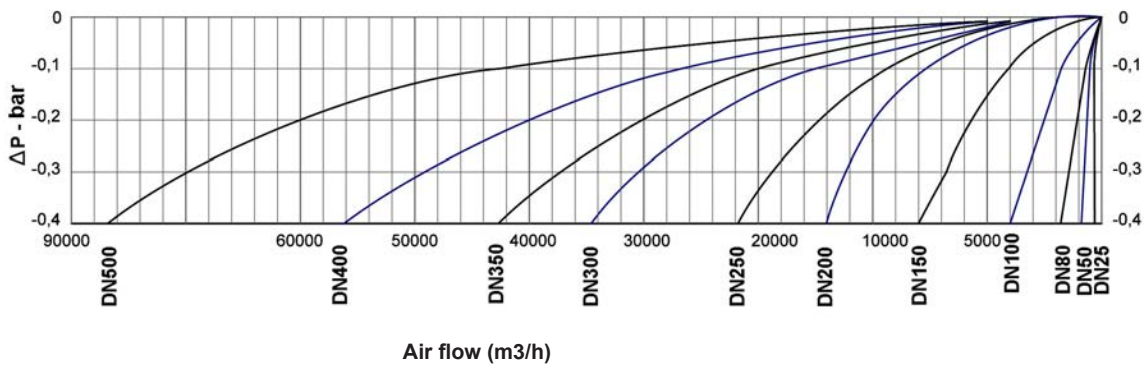

**Tecofi France**

83 rue Marcel Mérieux - 69960 Corbas  
Tél. +33 (0)4 72 79 05 79 - Fax. +33 (0)4 78 90 19 19  
E-mail : sales@tecofi.fr - [www.tecofi.fr](http://www.tecofi.fr)

