

Ref.: JT4243 .pas

Rev. : B

Fecha: 07/02/2019

Pág.: 1/1

# JUNTA DE DESMONTAJE PN16

## JT4243

ISO 9001  
BUREAU VERITAS  
Certification



EAC

**Tecofi'**  
VALVE DESIGNER - FRANCE



### APLICACIÓN

Uso general: Montaje y desmontaje fácil de valvulería destinada al agua y agua potable...

### CARACTERÍSTICAS GENERALES

Rango: a partir de DN 50 hasta DN 2000. Conexión PN16.

### CONSTRUCCIÓN

6	-	Arandela	Acero	Dacromet
5	-	Varilla roscada	Acero 4.8	Dacromet
4	1	Anillo de sellado	EPDM	WRAS
3	1	Brida de sujeción	Fundición dúctil EN-GJS-500-7	DIN: GGG50 ASTM: A536 70-50-05 BS: 500/7
2	1		Fundición dúctil EN-GJS-500-7	DIN: GGG50 ASTM: A536 70-50-05 BS: 500/7
1	1	Brida larga	Fundición dúctil EN-GJS-500-7	DIN: GGG50 ASTM: A536 70-50-05 BS: 500/7
Rep.	Num.	Designación	Material	



### DIMENSIONES

DN		$\Delta L$	L1	D5	D4	n-m	Espesor brida	Peso (kg)
mm	pulg.							
50	2"	50	215	165	125	M16*330*4	16+3	9,9
65	2 1/2"	50	215	185	145	M16*330*4	16+3	11,4
80	3"	50	225	200	160	M16*340*8	16+3	15,7
100	4"	50	225	220	180	M16*340*8	16+3	18,6
125	5"	50	225	250	210	M16*340*8	16+3	27,5
150	6"	50	245	285	240	M20*350*8	16+3	29
200	8"	50	235	340	295	M20*350*12	16+3	39,4
250	10"	50	250	400	355	M24*380*12	19+3	55
300	12"	50	265	455	410	M24*400*12	20.5+3	69,4
350	14"	50	265	520	470	M24*410*16	22.5+3	89
400	16"	50	300	580	525	M27*430*16	24+3	115
450	18"	50	295	640	585	M27*450*20	26+3	158,2
500	20"	50	295	715	650	M30*460*20	27.5+3	198
600	24"	50	315	840	770	M33*500*20	31+3	270
700	28"	50	325	910	840	M33*500*24	34.5+3	296
800	32"	50	340	1025	950	M36*530*24	38+3	386
900	36"	50	350	1125	1050	M36*530*28	41.5+3	456
1000	40"	50	360	1255	1170	M39*570*28	45+3	582
1200	48"	50	370	1485	1390	M45*620*32	52+3	740
1400	56"	50	380	1685	1590	M45*630*36	55+3	1360
1500	60"	50	400	1820	1710	M52*665*36	57+3	1510
1600	64"	50	400	1930	1820	M52*700*40	60+3	1690
1800	72"	50	420	2130	2020	M52*730*44	65+3	2500
2000	80"	50	440	2345	2230	M56*730*48	69+3	2930

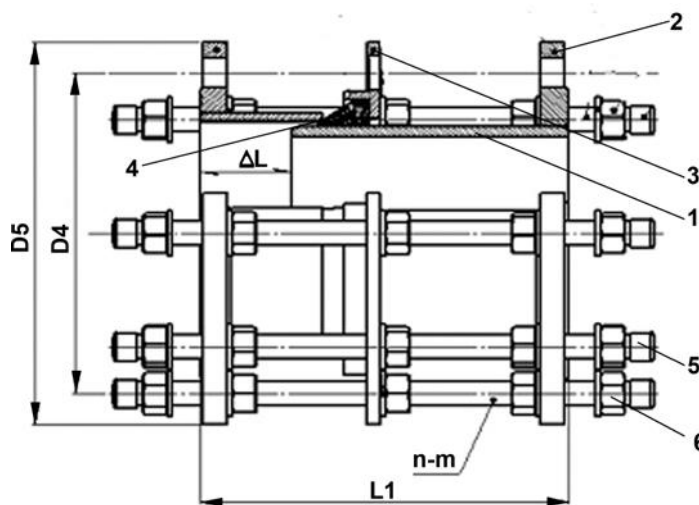

### CONDICIONES DE SERVICIO

Presión max. de servicio: 16 bar  
Temperatura max. de servicio: +4°C / +110°

### APROBACIÓN Y NORMAS

Presión de prueba según: EN12266-1

Cuerpo: 24 bar

Montaje con bridas EN 1092-2 PN16

Pintura epoxy RAL 5015, espesor 250 microns - WRAS

**TECOFI France** - 83, Rue Marcel Mérieux 69960 Corbas - FRANCE  
Tél. +33 (0) 4 72 79 05 79 - Fax +33 (0) 4 78 90 19 19 / +33 (0) 4 72 79 05 70  
Adresses e-mail : sales@tecofi.fr / Site web : [www.tecofi.fr](http://www.tecofi.fr)