

DISMANTLING JOINT

TECHNICAL PASSPORT

PN16 DISMANTLING JOINT

JT4243

APPLICATION

Dismantling joints mounted with flanged shut-off valves facilitate their assembly and disassembly by compensating for the axial movement of the piping.



Fluids : water, waste water, drinking water, compatible fluids, etc

GENERAL CHARACTERISTICS

Range : from DN50 to DN2000.
 Connection : PN10/16 (DN50-DN150) and PN16 beyond
 GEOMET 500® steel tie rods and nuts.
 Epoxy coating.
 Adjustment of +/-25 mm.



Epoxy coated body according to EN 14901 RAL 5015, 250 µm thickness (WRAS QUALITY)

CONSTRUCTION

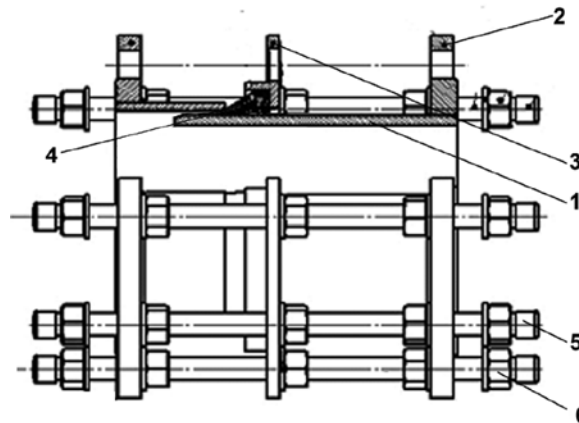

Pos.	Description	Material	Equivalence		
			DIN	ASTM	BS
1	Flanged pipe-long	Ductile iron EN-GJS-500-7	GGG50	A536 70-50-05	BS 500/7
2	Flanged pipe-short	Ductile iron EN-GJS-500-7	GGG50	A536 70-50-05	BS 500/7
3	Retaining flange	Ductile iron EN-GJS-500-7	GGG50	A536 70-50-05	BS 500/7
4	Sealing ring	EPDM (WRAS QUALITY)			
5	Stud bolt	Steel 4.8	GEOMET 500®		
6	Nut & tie rods	Steel	GEOMET 500®		

PRODUCT APPROVALS



Tecofi France

83 rue Marcel Mérieux - 69960 Corbas
 Tél. +33 (0)4 72 79 05 79 - Fax. +33 (0)4 78 90 19 19
 E-mail : sales@tecofi.fr - www.tecofi.fr



DISMANTLING JOINT

TECHNICAL PASSPORT

JT4243

DIMENSIONS

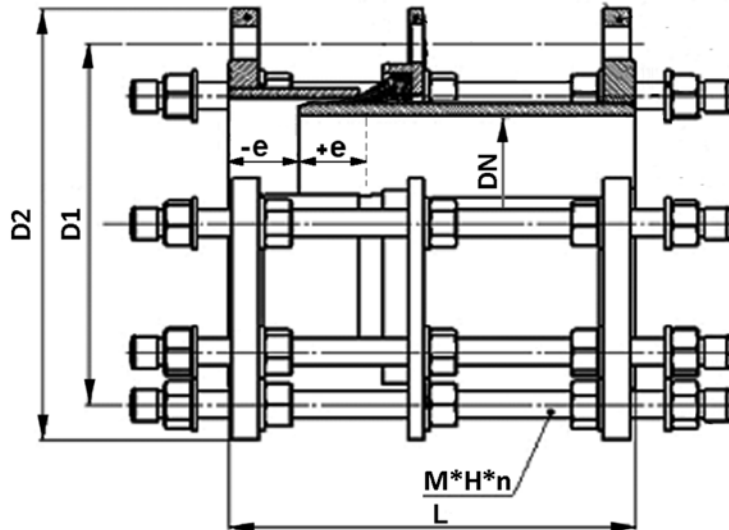

DN		e	L	øD1	øD2	M*H*n	FLANGE THICKNESS	Weight (kg)
mm	inch							
50	2"	25	215	125	165	M16*330*4	16+3	9.9
65	2 1/2"	25	215	145	185	M16*330*4	16+3	11.4
80	3"	25	225	160	200	M16*340*8	16+3	15.7
100	4"	25	225	180	220	M16*340*8	16+3	18.6
125	5"	25	225	210	250	M16*340*8	16+3	27.5
150	6"	25	225	240	285	M20*350*8	16+3	29
200	8"	25	235	295	340	M20*350*12	16+3	39.4
250	10"	25	250	355	400	M24*380*12	19+3	55
300	12"	25	265	410	455	M24*400*12	20.5+3	69.4
350	14"	25	265	470	520	M24*410*16	22.5+3	89
400	16"	25	275	525	580	M27*430*16	24+3	115
450	18"	25	295	585	640	M27*450*20	26+3	158.2
500	20"	25	295	650	715	M30*460*20	27.5+3	198
600	24"	25	315	770	840	M33*500*20	31+3	270
700	28"	25	325	840	910	M33*500*24	34.5+3	296
800	32"	25	340	950	1025	M36*530*24	38+3	386
900	36"	25	350	1050	1125	M36*530*28	41.5+3	456
1000	40"	25	360	1170	1255	M39*570*28	45+3	582
1200	48"	25	370	1390	1485	M45*620*32	52+3	740
1400	56"	25	380	1590	1685	M45*630*36	55+3	1360
1500	60"	25	400	1710	1820	M52*665*36	57+3	1510
1600	64"	25	400	1820	1930	M52*700*40	60+3	1690
1800	72"	25	420	2020	2130	M52*730*44	65+3	2500
2000	80"	25	440	2230	2345	M56*730*48	69+3	2930

WORKING CONDITIONS

Maximum working pressure: 16 bar
 Maximum working temperature: +4°C / +110°C

Tecofi France

83 rue Marcel Mérieux - 69960 Corbas
 Tél. +33 (0)4 72 79 05 79 - Fax. +33 (0)4 78 90 19 19
 E-mail : sales@tecofi.fr - www.tecofi.fr

