

RUBBER EXPANSION JOINT

TECHNICAL PASSPORT

COMPENSATEUR CAOUTCHOUC A BRIDES TOURNANTES

DI 7200-EA

APPLICATION

- Reduction of mechanical and thermal stresses on pipes and related systems : pumps, compressors, motors.
- Absorption of vibrations and noise
- Compensation of axial, lateral and angular movements
- Correction of misalignment of the piping.



Fluid: drinking water

GENERAL CHARACTERISTICS

- Range : from DN200 to DN300.
- Universal expansion joint consisting of :
 - EPDM ACS elastomer bellows
 - Swivel flanges made of carbon steel zinc plated.
 - Identical face to face for all diameters.



ACS

DIMENSIONS

DN		L	Movements				Weight (kg)
mm	inch		Axial compression (mm)	Axial extension (mm)	Lateral (mm)	Angular (degré)	
200	8"	130	12	10	12	15	16.80
250	10"	130	12	10	12	15	21.60
300	12"	130	12	10	12	15	30.10

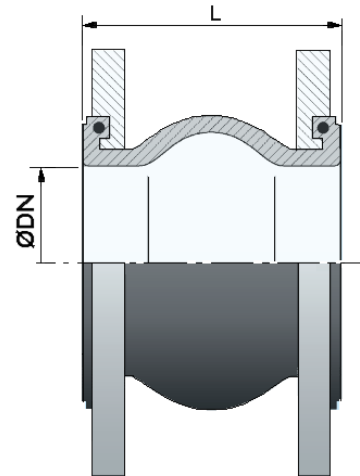

WORKING CONDITIONS

Maximum working pressure : 6 bar at 80°C

STANDARDS

Flanges PN10 according to standards EN1092-1, DIN 3230, BS 6755 and ISO 5208.

PRODUCT APPROVALS



Tecofi France

83 rue Marcel Mérieux - 69960 Corbas
Tél. +33 (0)4 72 79 05 79 - Fax. +33 (0)4 78 90 19 19
E-mail : sales@tecofi.fr - www.tecofi.fr

