

AIR INLET CHECK VALVE

TECHNICAL PASSPORT

CEA5245

FLANGED CARBON STEEL AIR INLET CHECK VALVE

APPLICATION

The air inlet check valve ensures rapid air entry with high flow rate in the piping when the latter is subjected to a vacuum.

Use: Potable water networks, raw water networks, irrigation networks.



Fluids: clear water, compatible liquids.

GENERAL CHARACTERISTICS

Range: from DN50 to DN300.

- Air inlet check valve with conical body and disc
- With sliding rod passing through a bronze bearing.
- Body assembled by bolting on flanged cone
- Profiling of internal parts ensuring high air flow
- Low pressure drop.
- Easy opening under low differential pressure.
- Metal/elastomer type sealing with oblique approach to the contact surfaces.
- Position of the disc modulated by the pressure of the pipe.

STANDARDS

Connection	Flanged connection according to EN1092-2, ISO 7005/2 , BS4504 : -PN10/16 from DN50 to DN150 -PN16 from DN200 to DN300
Essais	Pressure tests according to EN 12266-1, DIN 3230, BS 5154 et ISO 5208 : Body : 1.5 x PS Seat : 1.1 x PS
Coating	Epoxy coated body (250 microns) according to DIN 30677.

PRODUCT APPROVALS



Tecofi France

83 rue Marcel Mérieux - 69960 Corbas
Tél. +33 (0)4 72 79 05 79 - Fax. +33 (0)4 78 90 19 19
E-mail : sales@tecofi.fr - www.tecofi.fr



AIR INLET CHECK VALVE

TECHNICAL PASSPORT

CEA5245

CONSTRUCTION

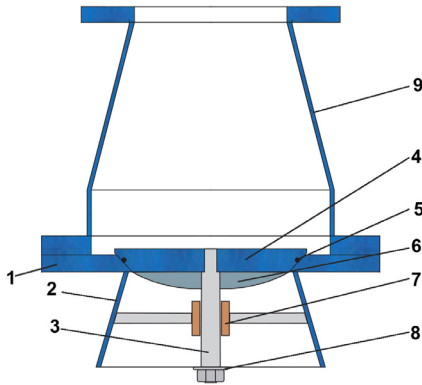

Pos.	Description	Material
1	Body	Steel St 37
2	Inlet cone	Steel St 37
3	Stem	Stainless steel 304
4	Disc	Steel St 37
5	Seat	NBR
6	Backing	PVC
7	Bearing	Bronze
8	Washer	Steel St 37
9	Connection cone	Steel St 37

DIMENSIONS

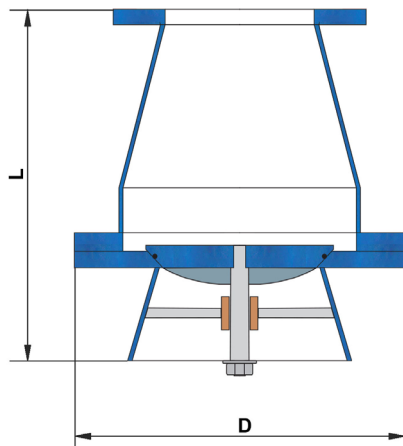

DN		L	D	Weight (kg)
mm	inch			
50	2"	280	250	17
80	3"	300	285	25
100	4"	340	340	33
150	6"	400	395	45
200	8"	470	445	70
250	10"	500	505	95
300	12"	520	565	110

WORKING CONDITIONS

Maximum working pressure: 16 bar
 Maximum working temperature : -10°C / 60°C

AIR INLET FLOW (l/s)

DN		Negative pressure (mCE)			
mm	inch	2 mCE	3 mCE	4 mCE	5 mCE
80	3"	1000	1300	1600	2000
100	4"	2000	2600	3200	4000
150	6"	3500	4550	5600	7000
200	8"	6000	7800	9600	12000
250	10"	10000	13000	16000	20000
300	12"	16000	20800	25600	32000

Tecofi France

83 rue Marcel Mérieux - 69960 Corbas
 Tél. +33 (0)4 72 79 05 79 - Fax. +33 (0)4 78 90 19 19
 E-mail : sales@tecofi.fr - www.tecofi.fr

