

TERMINAL CHECK VALVE

TECHNICAL PASSPORT

POLYESTER TERMINAL CHECK VALVE

CBT9200A

APPLICATION

TECOFI terminal check valve is used to protect pipes against the rise of fluid and the passage of animals

Areas of use: Treatment of domestic and industrial wastewater, irrigation, networks, rainwater and runoff reservoirs



Fluids: clear water, waste water, rain water, surface water, sea water.



GENERAL CHARACTERISTICS

Range: from DN200 to DN1500.

- Body and plate in polyester resin reinforced with glass fibers.
- Low mass structure with minimum face to face
- Easy and quick instauration
- Reduced pressure drop.
- Installation at the end of the networks on a vertical wall or a standard flange.
- Perfect seal ensured with gasket conforming to standard NF EN681-1.

Product advantage:

- Low weight for high pressure resistance
- Great long-term resistance to weathering, UV, ozone, to chemical attacks, mechanical stresses.
- High resistance to corrosion thanks to the 316 stainless steel stem.

STANDARDS

Connection	ISO PN10 flange mounting
-------------------	--------------------------

HOMOLOGATIONS PRODUITS

ERC

Tecofi France

83 rue Marcel Mérieux - 69960 Corbas
Tél. +33 (0)4 72 79 05 79 - Fax. +33 (0)4 78 90 19 19
E-mail : sales@tecofi.fr - www.tecofi.fr



TERMINAL CHECK VALVE

TECHNICAL PASSPORT

CBT9200A

CONSTRUCTION

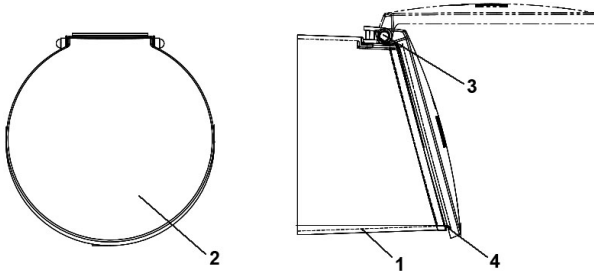

Pos.	Description	Material
1	Body	Glass fiber reinforced isophthalic polyester
2	Plate	Glass fiber reinforced isophthalic polyester
3	Stem	Stainless steel AISI 316
4	Gasket	EPDM

DIMENSIONS

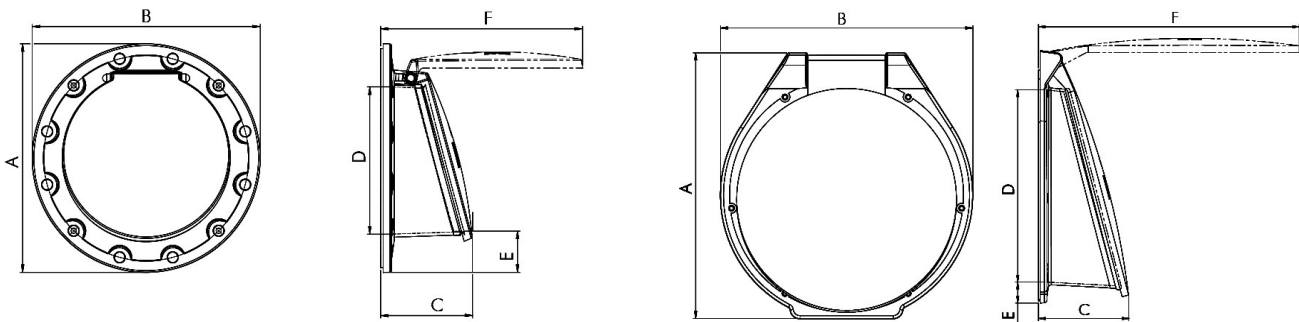

DN200-600

DN800-1500

DN		A	B	C	D	E	F	Weight (kg)
mm	inch							
200	8"	343	343	150	183	73	276	1.6
250	10"	395	395	160	245	67	332	2.0
300	12"	448	448	189	290	68	390	3.7
400	16"	570	570	206	375	86	482	6.5
500	20"	680	680	240	470	89	582	9.7
600	24"	791	791	280	599	78	712	14.3
800	32"	1032	1060	525	800	88	1075	25
1000	40"	1330	1265	535	1020	110	1390	102
1200	48"	1521	1440	695	1200	100	1620	151
1400	56"	1760	1640	800	1400	100	1820	236
1500	60"	1855	1740	870	1500	100	1965	285

WORKING CONDITIONS

Maximum working pressure : 10 mWC

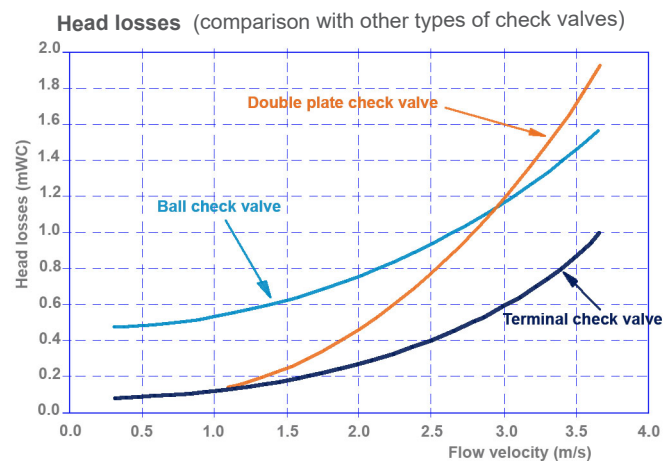

Tecofi France

83 rue Marcel Mérieux - 69960 Corbas
 Tél. +33 (0)4 72 79 05 79 - Fax. +33 (0)4 78 90 19 19
 E-mail : sales@tecofi.fr - www.tecofi.fr

