

Ref. : CB 4251 pas

Rev. : A

Date : 06/10/2016

Page : 1/1

# FLANGED PN25 SWING CHECK VALVE CB 4251



## APPLICATION

General uses: clear and slightly charged water, pumping, piping, irrigation, sewage systems.

## GENERAL CHARACTERISTICS

From DN 40 to 800,  
Epoxy coated body and cover.  
Mounting in horizontal and vertical ascending position.  
Simplicity in construction.  
Total lift swing at opening.  
Reliable and efficient functioning.  
Strong construction materials.  
Noiseless construction.

## CONSTRUCTION

6	Seal	EPDM
5	Shaft	X20CR13
4	Lever	Ductile iron
3	Disc	Steel + EPDM (DN40-400) Ductile iron (DN450-800)
2	Bonnet	Ductile iron
1	Body	Ductile iron
<b>Pos.</b>	<b>Description</b>	<b>Material</b>



## DIMENSIONS

DN		D	L	H	Weight (kg)
mm	inch				
40	1"1/2	150	180	100	10
50	2"	165	200	110	13
65	2"1/2	185	240	120	21
80	3"	200	260	140	22
100	4"	235	300	140	25
125	5"	270	350	200	40
150	6"	300	400	215	52
200	8"	360	500	265	149
250	10"	425	600	285	182
300	12"	485	700	370	316
350	14"	555	800	375	432
400	16"	620	900	550	550
450	18"	670	1000	515	670
500	20"	730	1100	660	880
600	24"	845	1300	610	1102
700	28"	960	1500	765	1800
800	32"	1085	1700	810	2250

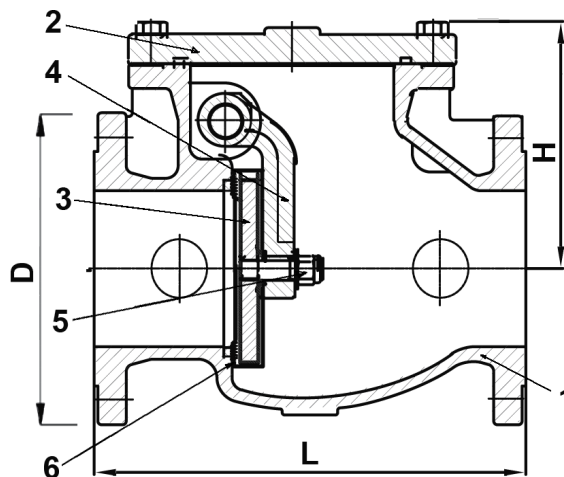

DN 40 - 400

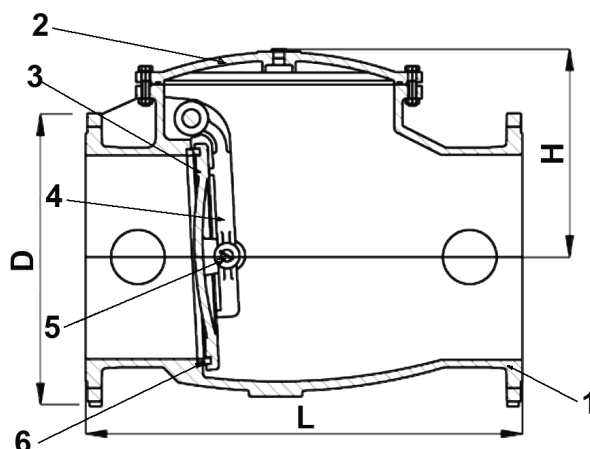

DN 450 - 800

## WORKING CONDITIONS

Maximum working pressure : 25 bar  
Working temperature: -10°C / +80°C

Pressure test according to standards  
EN 12266-1, DIN 3230, BS 6755 and ISO 5208.

## STANDARDS

Face to face according to standards :  
EN 558-1 serie 48 and DIN 3202/1 serie F6.  
Flanges PN25 drilled according to EN 1092-2 and DIN 2501/1

TECOFI France - 83, Rue Marcel Mérieux 69960 Corbas - FRANCE  
Tél. +33 (0) 4 72 79 05 79 - Fax +33 (0) 4 78 90 19 19 / +33 (0) 4 72 79 05 70  
Adresses e-mail : sales@tecofi.fr ; tecofi@tecofi.fr / Site web : www.tecofi.fr