

QUICK CLOSING NON-RETURN CHECK VALVE

TECHNICAL PASSPORT

AXIAL CHECK VALVE - DUCTILE IRON BODY BETWEEN FLANGES

CA 4460

APPLICATION

Protection of installation against back flow.

Area of use: distribution networks, water supply, pumping system, irrigation, chemical industry, etc.



-**Fluids:** water, drinking water, clear fluid lightly loaded water.



ACS

GENERAL CHARACTERISTICS

- **Range** : from DN 50 to DN500.
- Limit water hammer.
- Quick closing thanks to the short obturator stroke.
- Operates silently - No vibrations.
- 100% tightness of the plug in PU on metal seat.
- Damped closing due to obturator elasticity.
- Easy installation and maintenance required due to its design without seat gasket, absence of obturator wear.
- use in all installation positions : stainless steel counter spring.
- Low head losses.
- Robust and resistant body.
- Very low opening (cracking) pressure.

STANDARDS

Connection	Mounting is possible between flanges : -PN10, PN16, PN25 and PN40 according to standard ISO 2531 -ASA 150 and ASA 300 according to standard ASME B16.5.
Tests	Pressure test according to standards EN12266-1, DIN 3230, BS 5154 and ISO 5208: - Body : WP x 1.5 bar - Seat : WP x 1.1 bar

PRODUCT APPROVALS

CE **EAC** **ACS** Health compliance certificate ACS n° 19 ACC LY 031

Tecofi France

83 rue Marcel Mérieux - 69960 Corbas
Tél. +33 (0)4 72 79 05 79 - Fax. +33 (0)4 78 90 19 19
E-mail : sales@tecofi.fr - www.tecofi.fr



QUICK CLOSING NON-RETURN CHECK VALVE

TECHNICAL PASSPORT

CA 4460

CONSTRUCTION

The valves are coated with epoxy paint to protect them against corrosion

Component	Coating
Body	Epoxy powder RAL 5005 250 microns

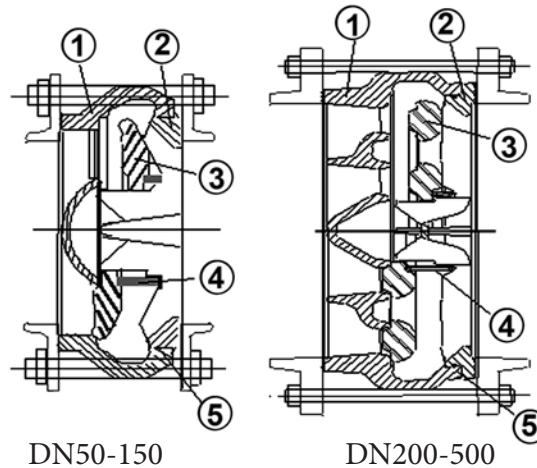

Pos.	Q-ty	Description	Material	Equivalences		
				DIN	ASTM	BS
1	1	Body	Ductile iron GGG40	GGG40	A48 class 408	1452 Grade 250
2	1	Ring	Ductile iron GGG40	GGG40	A48 class 408	1452 Grade 250
3	1	Obturator	Polyurethane			
4	1	Spring	Stainless steel 302			
5	1	Gasket	SBR			

DIMENSIONS

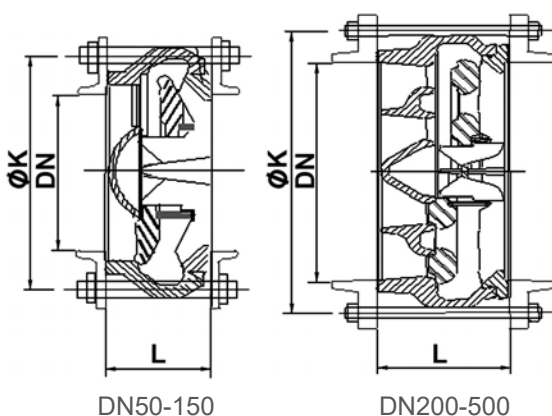

	DN		L	Ø K	Weight (kg)
	mm	inch			
	50	2"	50	91	1
	80*	3"	80	142	2
	100	4"	100	174	6
	125	5"	125	210	11
	150	6"	150	246	17
	200	8"	127	290	22
	250	10"	146	352	35
	300	12"	181	398	50
	350	14"	222	460	80
	400	16"	232	520	100
	450	18"	260	554	135
	500	20"	292	626	180

* - Can be mounted between DN65 flanges

Tecofi France

83 rue Marcel Mérieux - 69960 Corbas
Tél. +33 (0)4 72 79 05 79 - Fax. +33 (0)4 78 90 19 19
E-mail : sales@tecofi.fr - www.tecofi.fr



QUICK CLOSING NON-RETURN CHECK VALVE

TECHNICAL PASSPORT

CA 4460

DYNAMIC RESPONSE

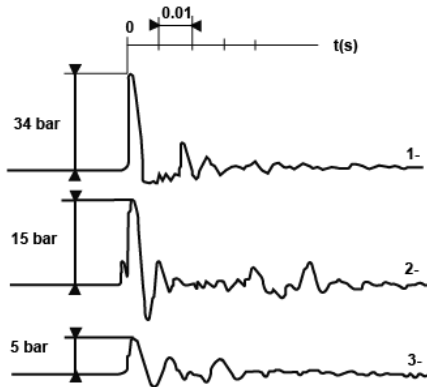

1. Single plate check valve
2. Double plate check valve
3. Quick closing check valve

WORKING CONDITIONS

Maximum working temperature : + 60°C

Maximum working pressure : corresponds to the PN within the limit of 40 bar maximum

DN	Cracking pressure (mWC)												
	mm	50	80	100	125	150	200	250	300	350	400	450	500
	inch	2"	3"	4"	5"	6"	8"	10"	12"	14"	16"	18"	20"
Starting opening pressure		0.39	0.43	0.45	0.45	0.55	0.4	0.41	0.44	0.47	0.63	0.65	0.7
Full opening pressure		0.50	0.65	0.67	0.80	0.90	0.68	0.68	0.69	0.66	0.79	0.92	0.93

- !** The operating pressure values must not exceed the PN of the flanges selected for the mounting.
 Cracking pressure : 0.8 bar
 Minimum counter-pressure for 100% sealing : 1 bar

Head loss chart

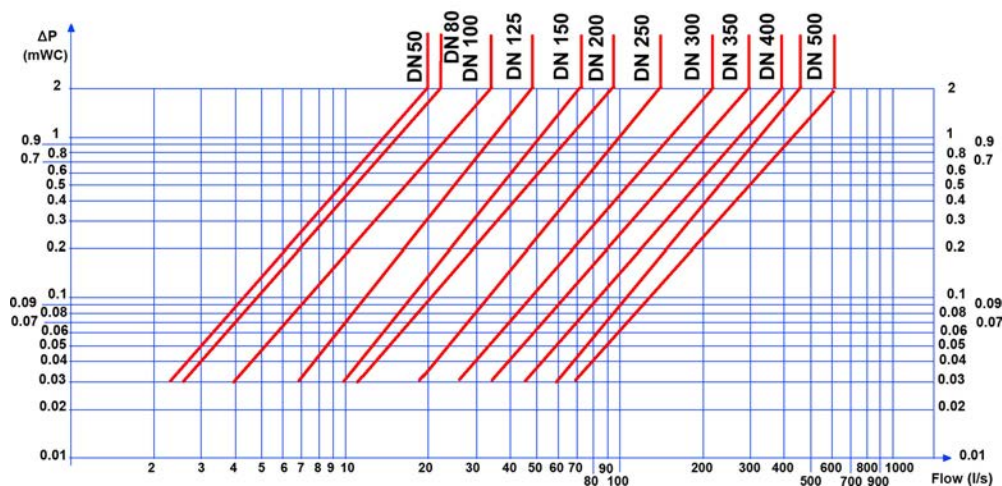

- !** During the mounting it is recommended to maintain a distance of 3 to 5 times the minimal diameter upstream and downstream of an elbow or appliance. This makes it possible to stay out of areas of turbulence likely to increase the risk of wear. At the discharge of a pump it is advisable to carry out the assembly in accordance with the FD CEN/TR 13932 standards.

Tecofi France

83 rue Marcel Mérieux - 69960 Corbas

Tél. +33 (0)4 72 79 05 79 - Fax. +33 (0)4 78 90 19 19

E-mail : sales@tecofi.fr - www.tecofi.fr

