

FLANGED AXIAL CHECK VALVE

TECHNICAL PASSPORT

FLANGED PN40 AXIAL CHECK VALVE DUCTILE IRON BODY

CA 4261

APPLICATION

Disc non-return check valve.

Area of use: Industries, fluid pumping, water supply, hydraulic networks, etc.



Fluids: clear water, uncharged liquids, non-corrosive, etc.



GENERAL CHARACTERISTICS

Range: from DN50 to DN600.

- Non-return valve in cast iron all positions.
- Simple axial guidance prevents blocking of the disc
- Body coated with powder epoxy paint from DN50 to DN400 and liquid epoxy powder from DN450.
- Mounting direction is indicated on the body by an arrow.
- Low cracking pressure.
- Low head losses.
- Simple installation and use.
- Stainless steel return spring for mounting in any position.
- Sealing ensured by flat EPDM gasket.

STANDARDS

Design	Design according to EN 12334
Connection	Flanges drilled according to EN 1092-2 and DIN 2501/1 : ISO PN40.
Tests	Pressure test according to standards EN12266-1, DIN 3230, BS 5154 and ISO 5208: Body : 60 bar Sèat : 44 bar

PRODUCT APPROVALS

ERC

Tecofi France

83 rue Marcel Mérieux - 69960 Corbas
Tél. +33 (0)4 72 79 05 79 - Fax. +33 (0)4 78 90 19 19
E-mail : sales@tecofi.fr - www.tecofi.fr



FLANGED AXIAL CHECK VALVE

TECHNICAL PASSPORT

CA 4261

CONSTRUCTION

Pos.	Description	Material
1	Body	Ductile iron
2	Cone	Ductile iron
3	Disc	Ductile iron
4	Stem	Stainless steel X20Cr13
5	Gasket	EPDM
6	Ring	Bronze
7	Spring	Stainless steel 304

Component	Coating
Body	Epoxy powder (DN50-400) and liquid (DN450-600) RAL 5005 thickness 150µm

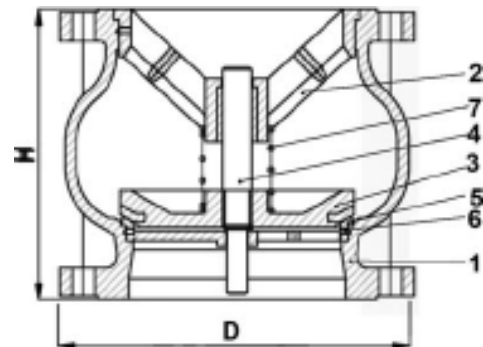

DN50-400

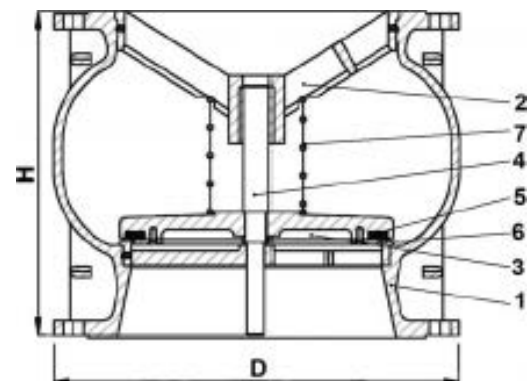

DN450-600

DIMENSIONS

DN		L	ØD	Weight (kg)
mm	inch			
50	2"	125	165	6
65	2"1/2	145	185	8
80	3"	155	200	12
100	4"	175	220	17
125	5"	200	250	23
150	6"	225	285	35
200	8"	275	340	60
250	10"	325	405	95
300	12"	375	460	130
350	14"	425	520	180
400	16"	475	580	240
450	18"	500	650	264
500	20"	587	715	380
600	24"	710	840	590

WORKING CONDITIONS

Maximum working pressure : 40 bar

Maximum working temperature : -10°C / +80°C

Tecofi France

83 rue Marcel Mérieux - 69960 Corbas

Tél. +33 (0)4 72 79 05 79 - Fax. +33 (0)4 78 90 19 19

E-mail : sales@tecofi.fr - www.tecofi.fr

