

BSP THREADED BALL VALVE

TECHNICAL PASSPORT

FULL BORE 3 PIECES BALL VALVE BSP THREADED ENDS - STAINLESS STEEL BODY

BSE 6189-02

APPLICATION

Area of use: Chemical industries, petrochemical industries, hydraulic installation, heating and water distribution



Fluids: water, oil, compatible liquid products.

GENERAL CHARACTERISTICS

- From DN 1/4" to DN 4"
- Packing gland insuring the tightness of the stem.
- Two part PTFE gasket
- Double sealing PTFE/Viton on the stem.
- Fire safe according to API 607.
- Full bore, anti blow-out stem.
- Handle with locking device.
- BSP female threaded connection according to ISO7/1.

CONSTRUCTION

Pos.	Description	Matériau	Pos.	Description	Matériau
1	Body	Stainless steel CF8M	11	Stem gasket	PTFE
2	End	Stainless steel CF8M	12	Packing	Stainless steel AISI 304
3	Ball	Inox AISI 316	13	Belleville washer	Stainless steel AISI 301
4	Seat	PTFE	14	Stopper nut	Stainless steel AISI 304
5	Body seal 1	PTFE	15	Plate washer	Stainless steel AISI 304
6	Body seal 2	PTFE	16	Nut	Stainless steel AISI 304
7	Bearing	PTFE	17	Handle	Stainless steel AISI 304
8	Stem	Stainless steel AISI 316	18	Bolt	Stainless steel AISI 304
9	O-ring	Viton	19	Cover	Plastic
10	O-ring	PTFE	20	Stop pin	Stainless steel AISI 304

DIMENSIONS

DN		d	L	H	h	k	W	C	S	ISO5211	Torque* (Nm)	Weight (kg)
inch	mm											
1/4"	8	11	50	70	42	8	117	9	42.6	F03/F04	5	0.53
3/8"	10	12.5	60	70	42	8	117	9	42.6	F03/F04	5	0.55
1/2"	15	15	75	70	42	8	117	9	42.6	F03/F04	5	0.82
3/4"	20	20	80	78	50	10	134	11	50.4	F04/F05	8	1.36
1"	25	25	90	87	58	10	134	11	50.4	F04/F05	10	1.83
1 1/4"	32	32	110	98	64	12.5	203	14	64.5	F05/F07	14	3.22
1 1/2"	40	40	120	104	69.5	12.5	203	14	64.5	F05/F07	18	4.47
2"	50	50	140	112	78	12.5	203	14	64.5	F05/F07	25	6.37
2 1/2"	65	65	185	140	100	15	255	17	93.6	F07/F10	48	8.58
3"	80	80	205	153	112.5	18	255	17	93.6	F07/F10	75	13.30
4"	100	100	240	166	125.5	18.5	302	17	93.6	F07/F10	110	22.30

* - Torque value without safety factor.

WORKING CONDITIONS

Maximum working pressure : 140 bar

Maximum working temperature: -25°C / +180°C.

PRODUCT APPROVALS



II 2 GD c T2

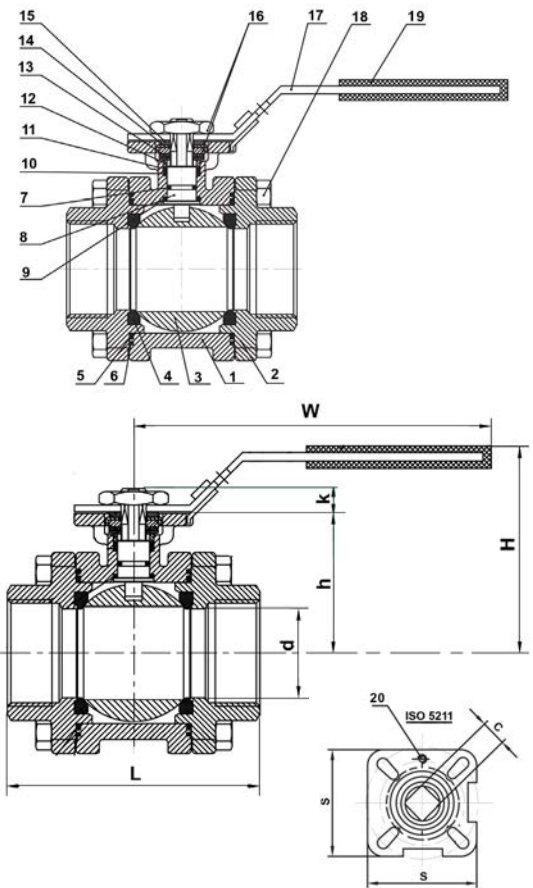

PRESSURE-TEMPERATURE RATING

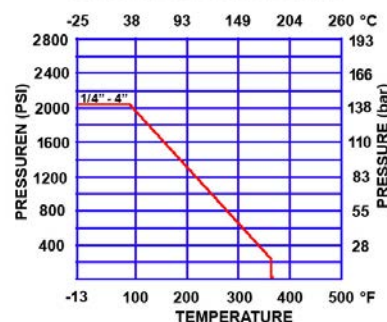

Tecofi France

83 rue Marcel Mérieux - 69960 Corbas

Tél. +33 (0)4 72 79 05 79 - Fax. +33 (0)4 78 90 19 19

E-mail : sales@tecofi.fr - www.tecofi.fr