

FLANGED BALL VALVE

TECHNICAL PASSPORT

2 PIECES FLANGED BALL VALVES STAINLESS STEEL BODY

BSD 6249-02

APPLICATION

Area of use: Chemical industries, petrochemical industries, hydraulic installation, heating and water distribution



Fluids: water, oil, compatible liquid products.

GENERAL CHARACTERISTICS

Range: From DN15 to DN200.

- Two pieces flanged model (split body).
- Fire safe design according to API 607.
- Full bore: fluid circulation without pressure drop.
- Inejctable axis: stability of the maneuvering system.
- PTFE seat.
- Handle with lockable device.
- ISO 5211 mounting plate compliant with all types of actuators.
- Floating ball.



STANDARDS

Connection	Flanged connection according to DIN EN1092-1 PN16/40 from DN15 to DN50 and PN16 from DN65 to DN200
Face to face	Face to face in accordance with: - EN558 serie 27 and DIN3202 F4 from DN15 to DN100 & DIN3202 F5 from DN125 to DN200.
Tests	Hydraulic tests carried out in accordance with standards EN12266 and API598.

PRODUCT APPROVALS



II 2 GD c T2



Tecofi France

83 rue Marcel Mérieux - 69960 Corbas
Tél. +33 (0)4 72 79 05 79 - Fax. +33 (0)4 78 90 19 19
E-mail : sales@tecofi.fr - www.tecofi.fr



FLANGED BALL VALVE

TECHNICAL PASSPORT

BSD 6249-02

CONSTRUCTION

DN15-100

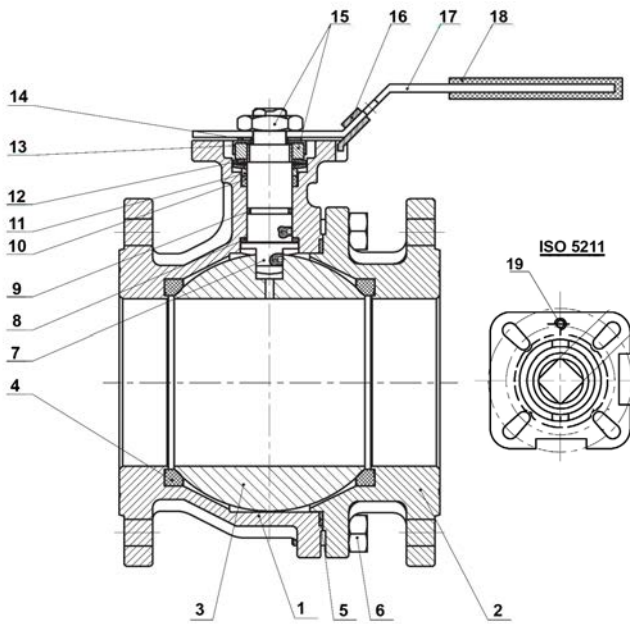

Pos.	Quantity	Description	Material
1	1	Body	ASTM A351 CF8M
2	1	Cap	ASTM A351 CF8M
3	1	Ball	Stainless steel AISI 316
4	2	Ball seat	PTFE
5	1	Body gasket	PTFE
6	4/6/8	Bolt	Stainless steel AISI 304
7	1	Stem	Stainless steel AISI 316
8	1	Thrust washer	PTFE
9	1	O-Ring	Viton
10	1	Stem packing	PTFE
11	1	Packing ring	Stainless steel AISI 304
12	2	Belleville washer	Stainless steel AISI 304
13	1	Nut stopper	Stainless steel AISI 304
14	1	Plate washer	Stainless steel AISI 304
15	2	Nut	Stainless steel AISI 304
16	1	Lock device	Stainless steel AISI 304
17	1	Handle	Stainless steel AISI 304
18	1	Cover	Plastic
19	1	Stop pin	Stainless steel AISI 304

DN125-200

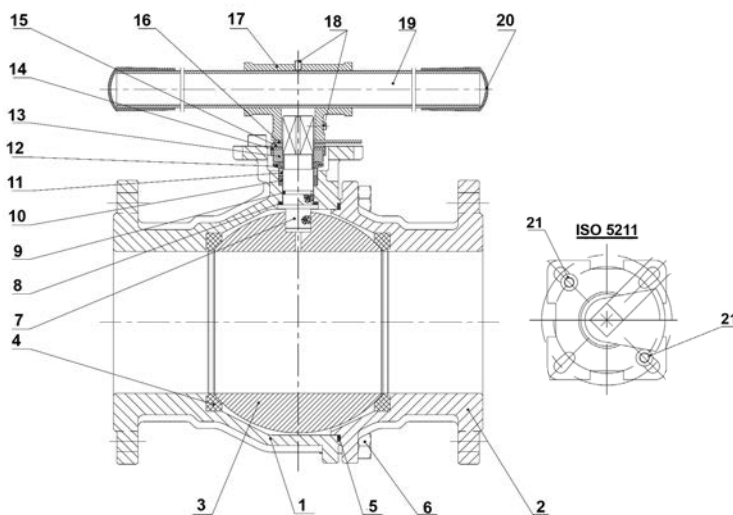

Pos.	Quantity	Description	Material
1	1	Body	ASTM A351 CF8M
2	1	Cap	ASTM A351 CF8M
3	1	Ball	Stainless steel AISI 316
4	2	Ball seat	PTFE
5	1	Body gasket	PTFE
6	4/6/8	Bolt	Stainless steel AISI 304
7	1	Stem	Stainless steel AISI 316
8	1	Thrust washer	PTFE
9	1	O-Ring	Viton
10	1	Stem packing	PTFE
11	1	Packing ring	Stainless steel AISI 304
12	2	Belleville washer	Stainless steel AISI 301
13	1	Nut	Stainless steel AISI 304
14	1	Nut stopper	Stainless steel AISI 304
15	1	Plate washer	Stainless steel AISI 304
16	1	Lock device	Stainless steel AISI 304
17	1	Sleeve	Stainless steel AISI 304
18	2	Vis	Stainless steel AISI 304
19	1	Handle	Stainless steel AISI 304
20	1	Cover	Plastic
21	1	Stop pin	Stainless steel AISI 304

Tecofi France

83 rue Marcel Mérieux - 69960 Corbas

Tél. +33 (0)4 72 79 05 79 - Fax. +33 (0)4 78 90 19 19

E-mail : sales@tecofi.fr - www.tecofi.fr



FLANGED BALL VALVE

TECHNICAL PASSPORT

BSD 6249-02

DIMENSIONS

DN15-100

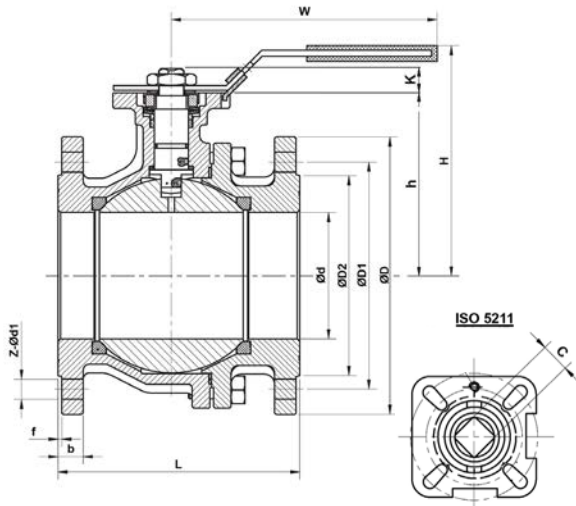

DN125-200

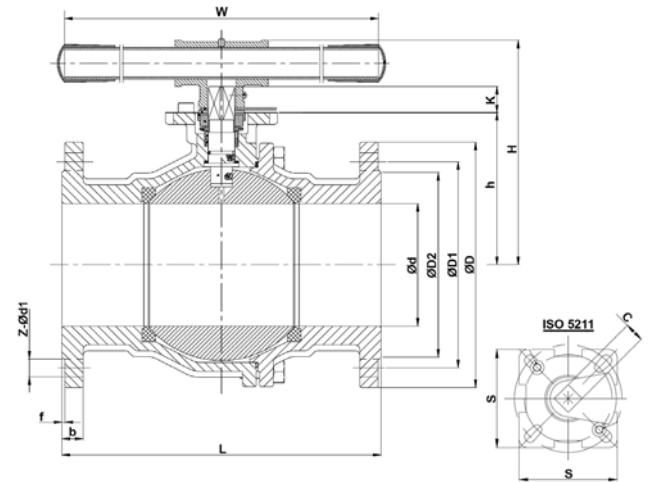

DN		d	L	D	D1	D2	b	f	H	W	C	K	ISO 5211	Z-ød1	h	s	Torque* (Nm)	Weight (kg)
mm	inch																	
15	1/2"	15	115	95	65	45	16	2	82	117	9	9	F03/F04	4-ø14	48	42.6	5	2.08
20	3/4"	20	120	105	75	58	18	2	87	117	9	9	F03/F04	4-ø14	53	42.6	8	2.8
25	1"	25	125	115	85	68	18	2	90	164	11	10	F04/F05	4-ø14	58.5	50	10	3.73
32	1 1/4"	32	130	140	100	78	18	2	100	164	11	12.5	F04/F05	4-ø18	71	50	14	5.18
40	1 1/2"	40	140	150	110	88	18	3	116	203	14	15	F05/F07	4-ø18	76.5	64.5	18	6.56
50	2"	50	150	165	125	102	20	3	125	203	14	13	F05/F07	4-ø18	85	64.5	25	8.9
65	2 1/2"	65	170	185	145	122	18	3	164	255	17	17	F07/F10	4-ø18	110	93.6	48	13.4
80	3"	80	180	200	160	138	20	3	174	255	17	18.8	F07/F10	8-ø18	122.5	93.6	75	18.2
100	4"	100	190	220	180	158	20	3	200	302	17	18.5	F07/F10	8-ø18	145.5	93.6	110	25.7
125	5"	125	325	250	210	188	22	3	258	600	22	21.5	F10/F12	8-ø18	185	114	200	47.5
150	6"	150	350	285	240	212	22	3	276	600	22	21.5	F10/F12	8-ø22	202.5	114	300	63.5
200	8"	200	400	340	295	268	24	3	350	800	27	27	F12/F14	12-ø22	257	131	400	115.3

* - Torque value without safety factor.

WORKING CONDITIONS

Maximum working temperature : -25°C / +180°C
 Maximum working pressure : 40 bar from DN15 to DN50
 16 bar from DN65 to DN200

PRESSURE-TEMPERATURE RATING

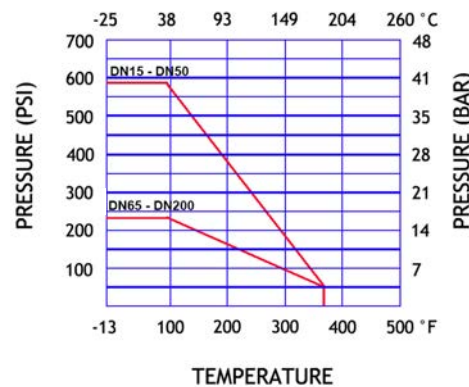

BSD6249-02_EN // Réalisé le 22/06/2021 // Version A

Tecofi France

83 rue Marcel Mérieux - 69960 Corbas
 Tél. +33 (0)4 72 79 05 79 - Fax. +33 (0)4 78 90 19 19
 E-mail : sales@tecofi.fr - www.tecofi.fr

