

## FLANGED BALL VALVE

### TECHNICAL PASSPORT

#### 2 PIECES CARBON STEEL BALL VALVES FLANGED CLASS 150 PN20

BSA 5241

#### APPLICATION

**Area of use:** Chemical industries, petrochemical industries, hydraulic installation, compressed air, heating and water distribution



**Fluids:** water, steam, oil, compatible liquid products.

#### GENERAL CHARACTERISTICS

**Range:** DN15 au DN200.

- Full bore
- Anti blow-out stem
- Double antistatic device
- PTFE filled with 15% glass seat
- Locking device
- ISO 5211 mounting pad
- 2 pieces type ( Split body )
- Hollowed ball from DN125 to DN200
- With exhaust hole in the ball ( located in the top of the ball to avoid overpressure in it )
- Primer coating for carbon steel valves



#### STANDARDS

<b>Design</b>	Meets the requirements of European Directive 2014/68/UE: «Equipment under pressure» modulate H. ATEX «ATmosphère EXplosive» n° 2014/34/UE. Design according to ASME B16.34 Fire safe according to API 607 6th Edition 2010 up to DN200 (8")
<b>Connection</b>	Flange connection Class 150 PN20 150 R.F. according to ASME B16.5
<b>Face to face</b>	Length according to ASME B16.10 ( EN 558 serie 3 up to DN100, serie 12 from DN125 to 200 )
<b>Test</b>	Pressure tests according to API 598, table 6

#### PRODUCT APPROVALS



#### Tecofi France

83 rue Marcel Mérieux - 69960 Corbas  
Tél. +33 (0)4 72 79 05 79 - Fax. +33 (0)4 78 90 19 19  
E-mail : sales@tecofi.fr - [www.tecofi.fr](http://www.tecofi.fr)



## FLANGED BALL VALVE

### TECHNICAL PASSPORT

BSA 5241

#### CONSTRUCTION DN15-50 (1/2"-2")

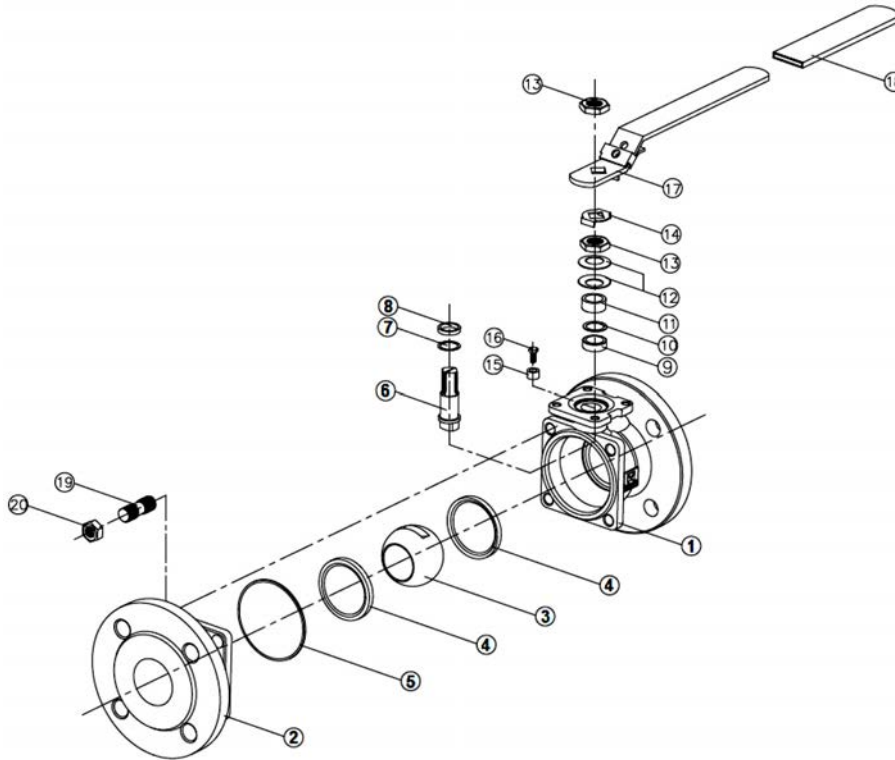

Pos.	Description	Material	Equivalences		
			DIN	ASTM	BS
1	Body	ASTM A216 WCB			
2	Ends	ASTM A216 WCB			
3	Ball	ASTM A351 CF8M			
4	Seat	PTFE filled with 15% glass			
5	Body seal	Graphite			
6	Stem	ASTM A276 316			
7	Ring	PTFE filled with 25% carbon			
8	Ring	PTFE filled with 25% carbon			
9	Packing	Graphite			
10	Packing	PTFE filled with 25% carbon			
11	Packing gland	AISI 304			
12	Elastic ring	AISI 301			
13	Nut	AISI 304			
14	Washer	AISI 304			
15	Pin	AISI 304			
16	Pin screw	AISI 304			
17	Handle	AISI 304			
18	Handle cover	PVC			
19	Stud	AISI 304			
20	Nut	AISI 304			

**Tecofi France**

83 rue Marcel Mérieux - 69960 Corbas  
 Tél. +33 (0)4 72 79 05 79 - Fax. +33 (0)4 78 90 19 19  
 E-mail : sales@tecofi.fr - [www.tecofi.fr](http://www.tecofi.fr)



## FLANGED BALL VALVE

### TECHNICAL PASSPORT

BSA 5241

#### CONSTRUCTION DN65-100 (2"1/2-4")

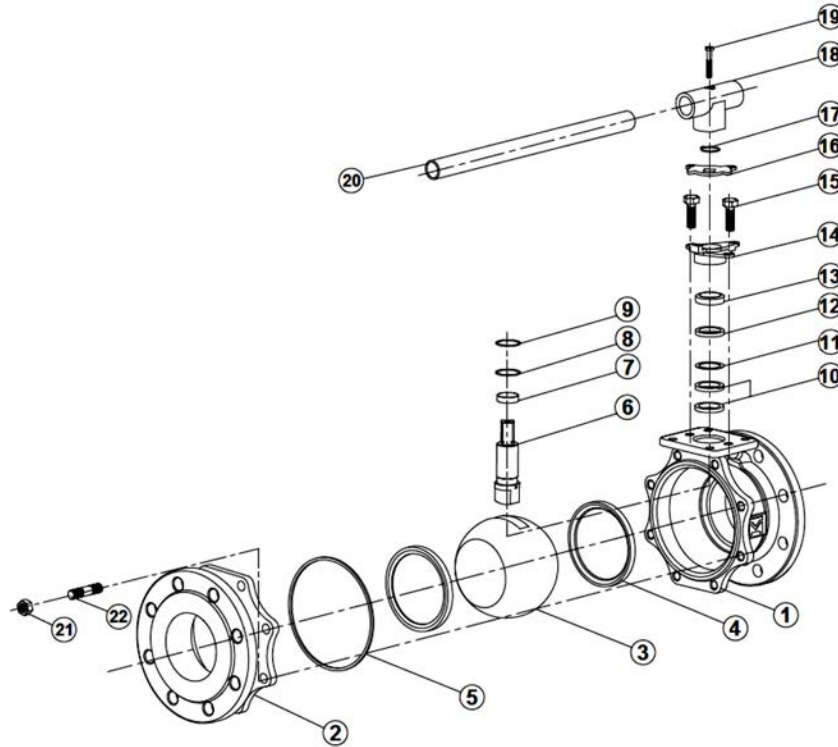

Pos.	Description	Material	Equivalences		
			DIN	ASTM	BS
1	Body	ASTM A216 WCB			
2	Ends	ASTM A216 WCB			
3	Ball	ASTM A351 CF8M			
4	Seat	PTFE filled with 15% glass			
5	Body seal	Graphite			
6	Stem	ASTM A276 316			
7	Ring	PTFE filled with 25% carbon			
8	Ring	PTFE filled with 25% carbon			
9	Ring	PTFE filled with 25% carbon			
10	Packing	Graphite			
11	Packing	PTFE filled with 25% carbon			
12	Ring	AISI 304			
13	Ring	AISI 304			
14	Packing gland	ASTM A351 CF8			
15	Packing gland screw	AISI 304			
16	Pin	AISI 304			
17	Circlips	AISI 304			
18	Handle adaptor	ASTM A351 CF8			
19	Screw	AISI 304			
20	Handle	AISI 304			
21	Nut	AISI 304			
22	Stud	AISI 304			

The photographs and technical art works are not contractual. The specifications of the presented products are open to modifications without previous advice

**Tecofi France**

83 rue Marcel Mérieux - 69960 Corbas  
 Tél. +33 (0)4 72 79 05 79 - Fax. +33 (0)4 78 90 19 19  
 E-mail : sales@tecofi.fr - [www.tecofi.fr](http://www.tecofi.fr)



## FLANGED BALL VALVE

### TECHNICAL PASSPORT

BSA 5241

#### CONSTRUCTION DN125-200 (5" - 8")

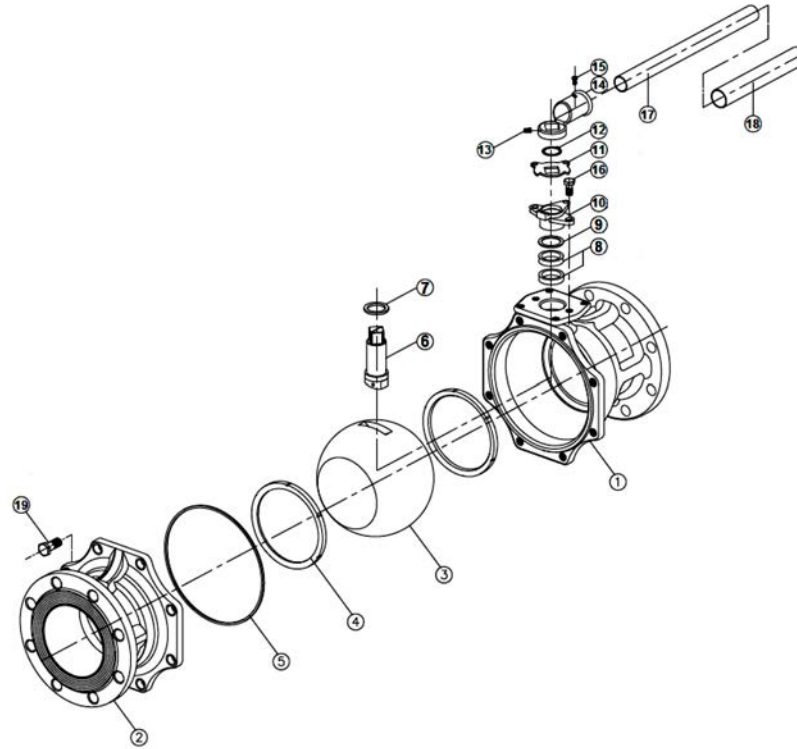

Pos.	Description	Material	Equivalences		
			DIN	ASTM	BS
1	Body	ASTM A216 WCB			
2	Ends	ASTM A216 WCB			
3	Ball	AISI 316			
4	Seat	PTFE filled with 15% glass			
5	Body seal	Graphite			
6	Stem	ASTM A276 316			
7	Ring	PTFE filled with 25% carbon			
8	Packing	Graphite			
9	Packing	PTFE filled with 25% carbon			
10	Packing gland	ASTM A351 CF8			
11	Pin	AISI 304			
12	Circlips	AISI 304			
13	Screw	AISI 304			
14	Handle adaptor	AISI 304			
15	Screw	AISI 304			
16	Packing gland screw	AISI 304			
17	Handle	AISI 304			
18	Handle cover	PVC			
19	Body screw	AISI 304			

**Tecofi France**

83 rue Marcel Mérieux - 69960 Corbas  
 Tél. +33 (0)4 72 79 05 79 - Fax. +33 (0)4 78 90 19 19  
 E-mail : sales@tecofi.fr - [www.tecofi.fr](http://www.tecofi.fr)



## FLANGED BALL VALVE

### TECHNICAL PASSPORT

#### BSA 5241

#### DIMENSIONS

##### DN15-50

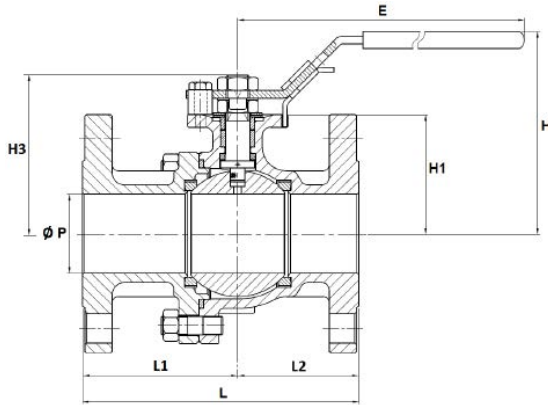

DN	mm	15	20	25	32	40	50
	inch	1/2"	3/4"	1"	1 1/4"	1 1/2"	2"
Ø P		15	20	24	30	38	50
L		108	117	127	140.2	165	178
L1		61	65	72.5	78.2	90.8	98
L2		47	52	54.5	62	74.2	80
E		158	158	196	196	245	261
H		76.6	79.1	92	96	121.1	127.6
H1		39	42.5	52	56	66	73
H3		53.5	56.5	70	73	88	94.5
Weight ( Kg)		1.9	2.4	3.4	4.2	6.1	8.8

##### DN65-100

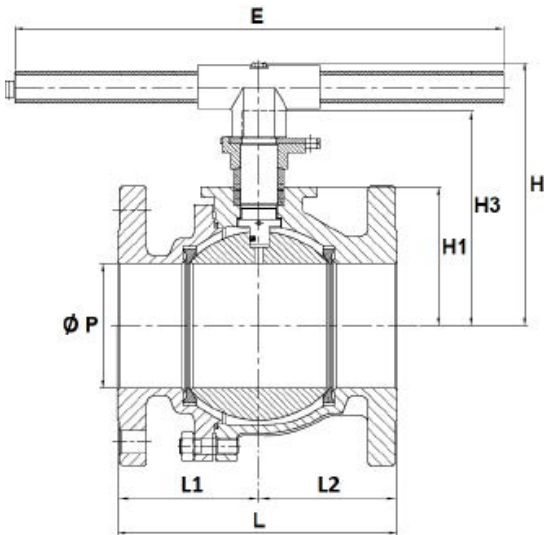

DN	mm	65	80	100
	inch	2 1/2"	3"	4"
Ø P		64	76	98
L		190	203	229
L1		100.3	109.2	119.3
L2		89.7	93.8	109.7
E		400	400	400
H		188	194	215
H1		86.5	91.5	113.5
H3		152	158	179
Weight ( Kg)		16.4	19.5	28.1

##### DN125-200

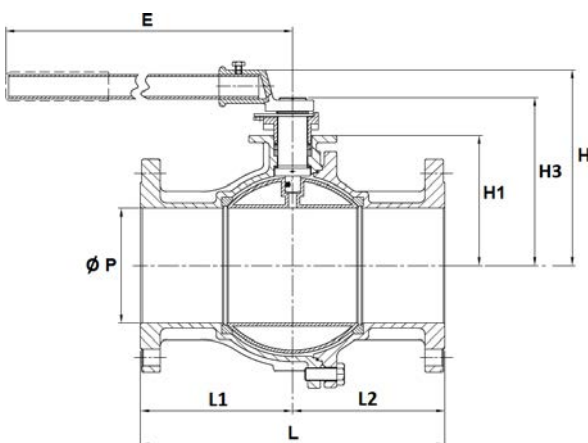

DN	mm	125	150	200
	inch	5"	6"	8"
Ø P		125	150	200
L		356	394	457
L1		176.7	197	226
L2		179.3	197	231
E		743	743	840
H		239.6	256.5	334
H1		147	170	215
H3		199	220	300.5
Weight ( Kg)		40	54	88

**Tecofi France**

83 rue Marcel Mérieux - 69960 Corbas  
 Tél. +33 (0)4 72 79 05 79 - Fax. +33 (0)4 78 90 19 19  
 E-mail : sales@tecofi.fr - [www.tecofi.fr](http://www.tecofi.fr)



## FLANGED BALL VALVE

### TECHNICAL PASSPORT

BSA 5241

#### MOUNTING PLATE DIMENSIONS

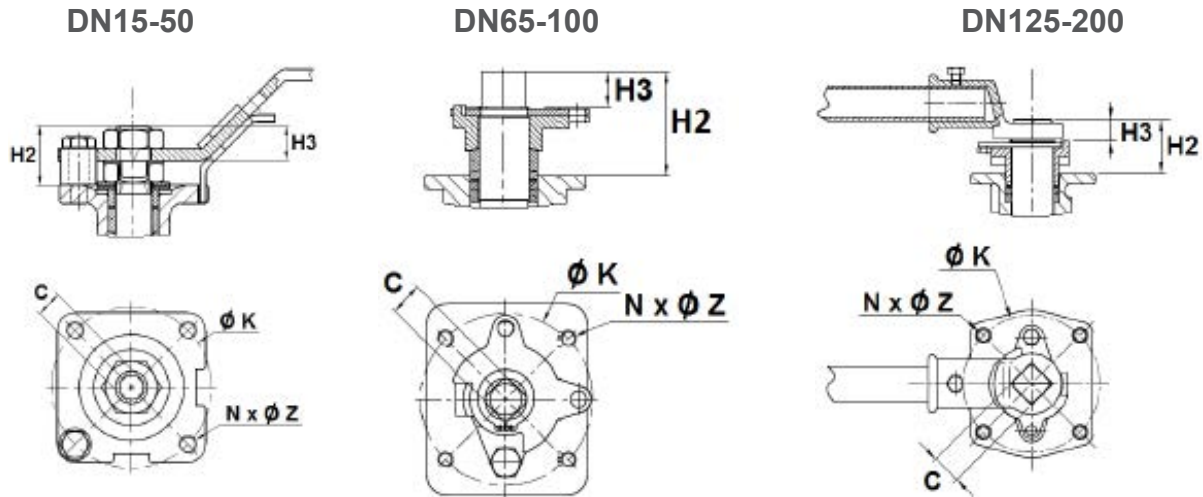

DN	mm	15	20	25	32	40	50	65	80	100	125	150	200
	inch	1/2"	3/4"	1"	1"1/4	1"1/2	2"	2"1/2	3"	4"	5"	6"	8"
Ø C		35	42.9	50.8	63.5	73	92.1	104.8	127	157.2	186	216	270
Ø D		90	100	110	115	125	150	180	190	230	254	279	343
Ø K		60.3	69.9	79.4	88.9	98.4	120.7	139.7	152.4	190.5	216	241.5	298.5
Nb x Ø L		4 x 15.8	4 x 15.8	4 x 15.8	4 x 15.8	4 x 15.8	4 x 19	4 x 19	4 x 19	8 x 19	8 x 22	8 x 22	8 x 22.5
b		11.2	12.7	14.3	15.9	17.5	19	22.3	23.9	23.9	23.9	25.4	28.6
e		1.6	1.6	1.6	1.6	1.6	1.6	1.6	1.6	1.6	1.6	1.6	1.6
Kvs m <sup>3</sup> /h		31	58	86	139	229	415	698	983	1686	2824	3953	7225
Torque (Nm)		8	10	12	20	30	40	60	90	130	160	250	500

#### WORKING CONDITIONS

Min and max Temperatures Ts : -20°C to + 200°C  
 Max Pressure Ps : 20 bars ( see graph under )  
 Maximum pressure for steam : 11 bar

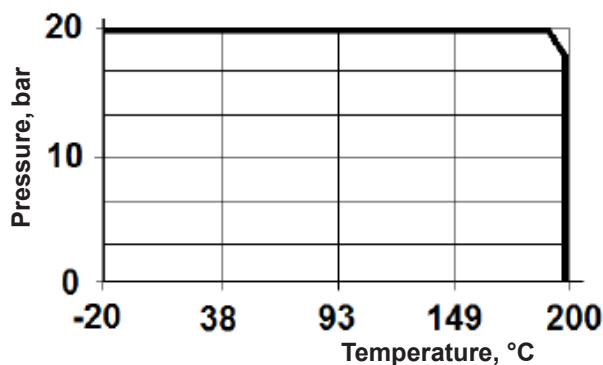

**Tecofi France**

83 rue Marcel Mérieux - 69960 Corbas  
 Tél. +33 (0)4 72 79 05 79 - Fax. +33 (0)4 78 90 19 19  
 E-mail : sales@tecofi.fr - [www.tecofi.fr](http://www.tecofi.fr)

