

Ref. : BS 6379NPT pas

Rev. : Initial

Date : 11/12/2014

Page : 1/1

3PIECES FULL BORE BALL VALVE PN63

BS 6379NPT



APPLICATION

General use : Chemical and pharmaceutical, industries, petrochemical industries.

GENERAL CHARACTERISTICS

From DN1/4" to DN 4".
Full bore.
Anti blowing-out stem.
PTFE packing.
Locking device. Two parts seat for DN3/8".
Stem extension in stainless steel 304 (option).
Blue handle cover possible.

CONSTRUCTION

12	Handle	Stainless steel 304
11	Locking device	Stainless steel 304
10	Handle nut	Stainless steel 304
9	packing nut	Stainless steel 304
8	Packing	PTFE
7	Thrust washer	PTFE
6	Body gasket	PTFE filled with 15% glass
5	Seat	PTFE filled with 15% glass
4	Ends	ASTMA351 CF8M
3	Stem	Stainless steel 316
2	Ball	ASTMA351 CF8M
1	Body	ASTMA351 CF8M
Pos.	Description	Material



DIMENSIONS

DN		L	E	H	T	T1	W	Weight (kg)
mm	inch							
8	1/4"	60	136	52	27,2	51	18	0,33
10	3/8"	60	136	52	27,2	51	22	0,34
15	1/2"	63	136	63	31,8	59,5	26	0,49
20	3/4"	70	136	68	40	71	33	0,64
25	1"	82	165	79	45	80	40	0,96
32	1 1/4"	96	165	88	53	91,5	48	1,37
40	1 1/2"	107	190	97	63,3	106	55	2,2
50	2"	124	190	108	78,8	132,8	67	3,75
65	2 1/2"	164,6	300	128	98,3	164	84,5	6,85
80	3"	182,7	300	140	116,6	194	101	10,2
100	4"	217,7	335	172	200,5	231,5	127	20,5

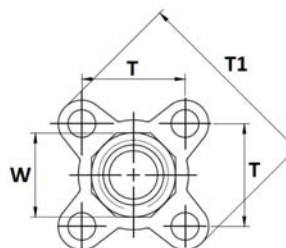
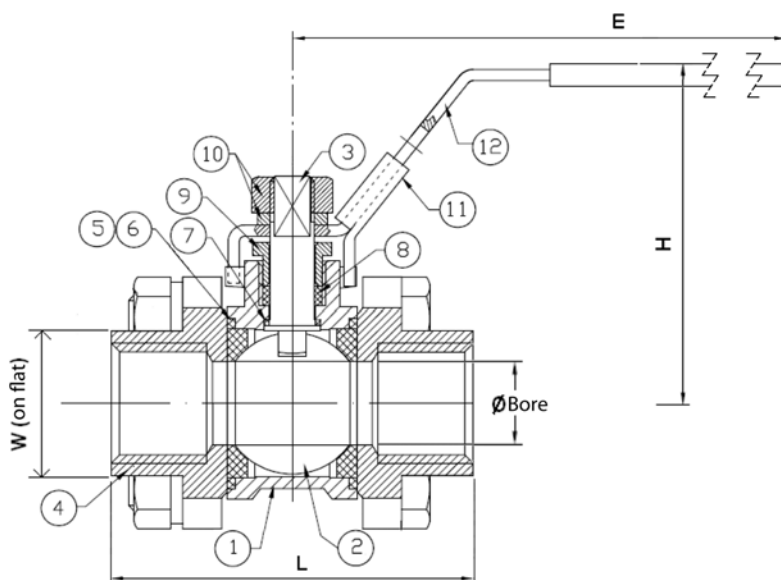

DN 1/4" - 3"

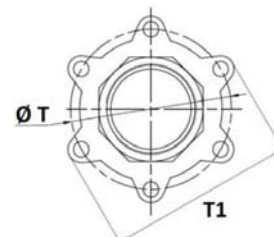

DN 4"

WORKING CONDITIONS

Maximum working temperature : -20°C / + 180°C
Maximum pressure depends on DN

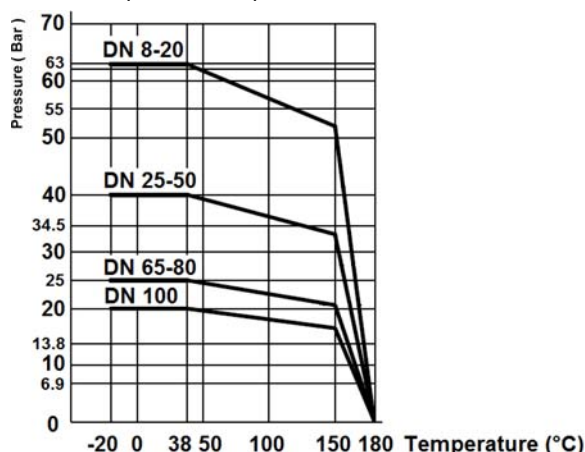

STANDARDS

Fabrication according to ISO 9001: 2008.
Pressure tests according to EN 12266-1, range A.
Connection NPT according to ANSI B1.20.1.

TECOFI France - 83, Rue Marcel Mérieux 69960 Corbas - FRANCE
Tél. +33 (0) 4 72 79 05 79 - Fax +33 (0) 4 78 90 19 19 / +33 (0) 4 72 79 05 70
Adresses e-mail : sales@tecofi.fr ; tecofi@tecofi.fr / Site web : www.tecofi.fr