

Ref. : BS 6245

Rev. : B

Date : 15/04/2020

Page : 1/1

# FLANGED PN16 3 PIECES FULL BORE STAINLESS STEEL BALL VALVE PN63 WITH HANDLE

**BS 6245**



## APPLICATION

General use : Chemical and pharmaceutical industries, petrochemical industries, hydraulic installation, compressed air.

## GENERAL CHARACTERISTICS

Full bore, anti blow-out stem  
Food grade PTFE packing and seal in accordance with standard FDA n° 21CFR 177.1550.  
With ISO top flange for actuator installation



## CONSTRUCTION

12	Stop pin	Stainless steel 304
11	Gland nut	Stainless steel 304
10	Handle	Stainless steel
9	Stem	ASTM A276-316
8	Packing	PTFE
7	Washer	PTFE
6	Seal	PTFE
5	Seat	RTFE
4	Anti static device	Stainless steel 316
3	Ball	Stainless steel A351 CF8M
2	Retainer	Stainless steel 1.4408
1	Body	Stainless steel 1.4408
<b>Pos.</b>	<b>Description</b>	<b>Material</b>

## WORKING CONDITIONS

Maximum working pressure : 16 bar  
Maximum working temperature: -20°C /+200°C.

Test pressure according to EN 12266-1, DIN 3230, BS 5154 et ISO 5208 :

Body : Working pressure x 1.5 (bar)  
Seat : Working pressure x 1.1 (bar)

## STANDARDS

Flanged connection ISO PN16 according to EN 1092-1.

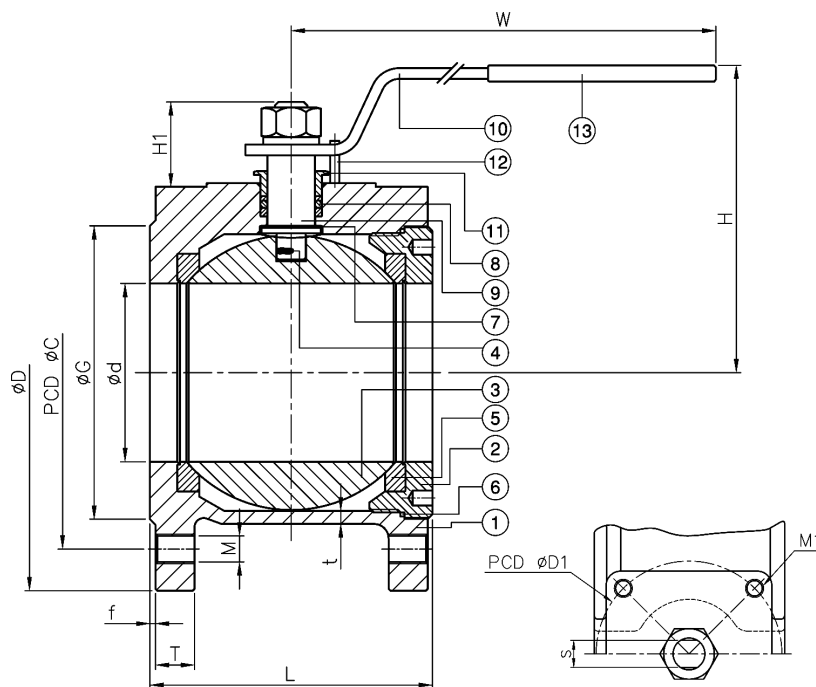

## DIMENSIONS

DN		d	G	C	D	L	H	H1	W	S	ISO	D1	T	f	t	M	M1	Torque Nm	Weight (kg)
mm	inch																		
15	1/2"	15	45	65	88	36	70	21,7	150	7,8	F03	36	6	1	12	M12	M5	5,5	1,2
20	3/4"	20	58	75	98	38	70	22	150	7,8	F03	36	6	1	11,5	M12	M5	7,5	1,4
25	1"	25	68	85	108	43	80	25	150	8	F03	36	7	1,8	14	M12	M5	8,5	1,9
32	1" 1/4	32	78	100	128	51	87	28	156	8	F03	36	7	1,8	14,1	M16	M5	12	2,9
40	1" 1/2	38	88	110	150	63	102	29	180	10	F05	50	13	1,5	6	M16	M6	20	4,4
50	2"	50	102	125	165	70	108	29	180	10	F05	50	14	1,5	5,5	M16	M6	30	5,6
65	2" 1/2	65	123	145	186	107	143	41	282	12	F07	70	14	1,5	6	M16	M8	50	9,9
80	3"	76	138	160	200	120	152	40	290	12	F07	70	15	2	5,5	M16	M8	65	12,6
100	4"	96	158	180	220	152	168	40	325	15	F10	102	17	2,5	7	M16	M10	90	19,7
125	5"	118	188	210	250	196	230	76	300x2	22	F10	102	19	3	6,5	M16	M10	130	29,2
150	6"	135	212	285	240	236	243	76	300x2	22	F12	125	19	3	7	M20	M12	140	39,8

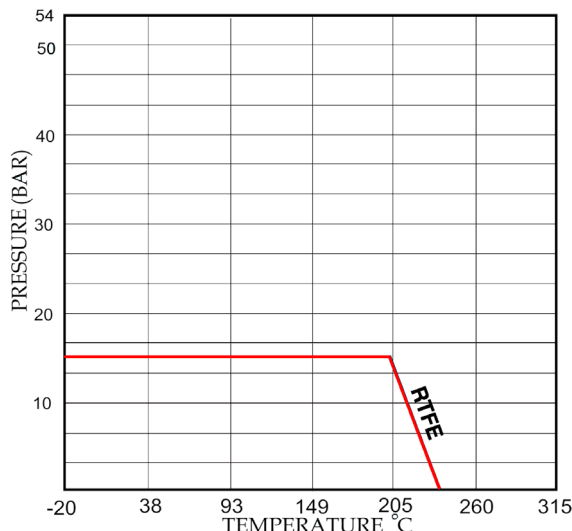

**TECOFI France** - 83, Rue Marcel Mérieux 69960 Corbas - FRANCE  
Tél. +33 (0) 4 72 79 05 79 - Fax +33 (0) 4 78 90 19 19 / +33 (0) 4 72 79 05 70  
Adresses e-mail : sales@tecofi.fr ; tecofi@tecofi.fr / Site web : [www.tecofi.fr](http://www.tecofi.fr)