

Ref. : BS 5379BW pas

Rev. : B

Date : 19/03/2020

Page : 1/1

# 3PIECES FULL BORE BALL VALVE PN63

## BS 5379SW



**Tecofi**  
VALVE DESIGNER - FRANCE

### APPLICATION

General use : Compatible with common fluids of 2nd group.

### GENERAL CHARACTERISTICS

From DN1/4" to DN 4".  
Full bore.  
Anti blowing-out stem.  
PTFE packing.  
Locking device.  
Stem extension in stainless steel 304 (option).  
Black phosphated finish, thickness 5 microns.



### CONSTRUCTION

12	Handle	Stainless steel 304
11	Locking device	Stainless steel 304
10	Handle nut	Stainless steel 304
9	Packing nut	Stainless steel 304
8	Packing	PTFE
7	Thrust washer	PTFE
6	Body gasket	PTFE
5	Seat	PTFE filled with 15% glass
4	Ends	ASTMA216 WCB
3	Stem	Stainless steel 304
2	Ball	Stainless steel 304
1	Body	ASTMA216 WCB
Pos.	Description	Material

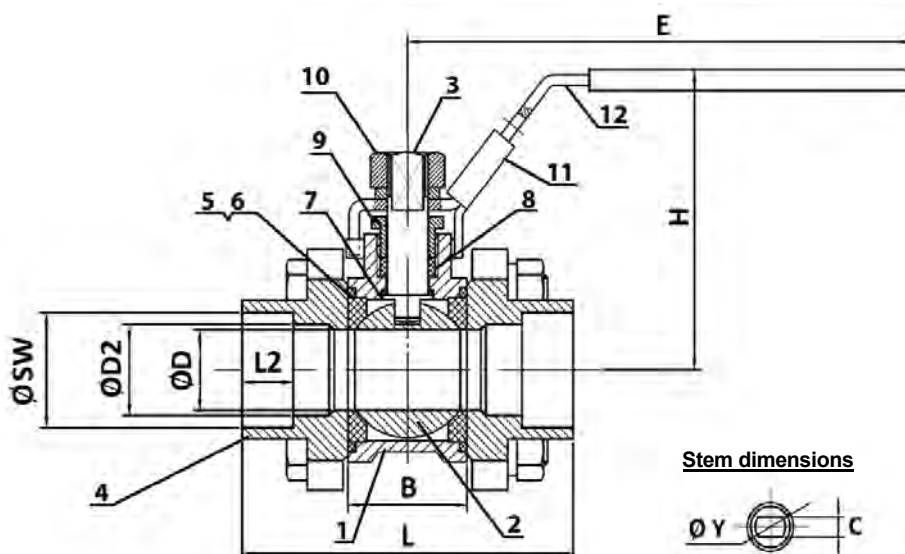

Stem dimensions

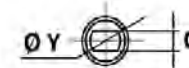

### DIMENSIONS

DN		L	ØD	B	E	H	ØY	C	ØT	T1	ØBW	ØBW1	ØD2	kvs (m3/h)	Torque (Nm)	Weight (kg)
mm	inch															
8	1/4"	59	12	21,1	103	49	M8	5	38,5	51	15,5	13,3	11,6	12,4	4	0,33
10	3/8"	59	13	21,1	103	49	M8	5	38,5	51	17,5	14,5	12,5	24,01	4	0,33
15	1/2"	63,3	15	23,3	126	57	M8	5	43	57,5	22	17	15	33	8	0,45
20	3/4"	70,6	20	28,6	126	62	M8	5	61,5	66	27,3	22,5	20	58,6	8	0,60
25	1"	82	25	34	162	72	M8	6,5	58	74,5	34	28,6	25	91,6	10	0,86
32	1"1/4	97	32	44	162	78	M10	6,5	70	86,5	42,7	36	32	148,2	13	1,35
40	1"1/2	109	38	51	193	91	M10	8,5	81,5	100,5	48,7	43	39,8	211,6	20	2,03
50	2"	124,6	50	63	193	102	M12	8,5	101	121,5	61	54	50	366,4	20	3,19
65	2"1/2	162	64	84,3	230	122	M14	9,8	136	161	76,5	68	64	619,2	35	7,06
80	3"	175	76	94,7	230	132	M14	9,8	157	185	90	84	76	938	45	10,70
100	4"	216	100	119,2	320	177	M20	16	195,5	226,5	115	104	100	1465,6	65	20,95

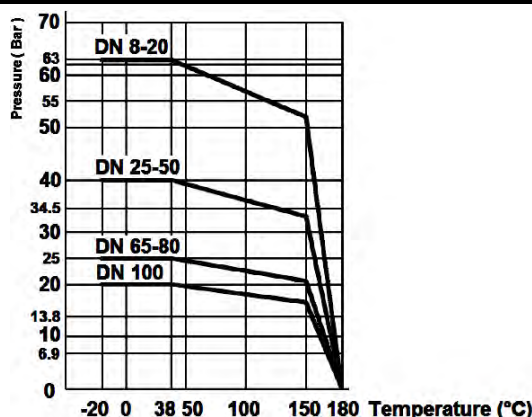
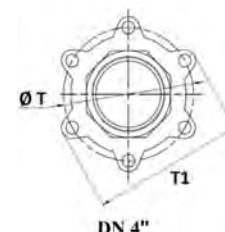
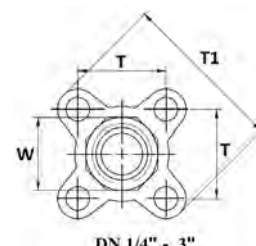

### WORKING CONDITIONS

Maximum working temperature : -20°C / + 180°C  
Maximum pressure depends on DN

### STANDARDS

Fabrication according to ISO 9001: 2008.  
Pressure tests according to EN 12266-1, range A.  
Connection SW.

**TECOFI France** - 83, Rue Marcel Mérieux 69960 Corbas - FRANCE  
Tél. +33 (0) 4 72 79 05 79 - Fax +33 (0) 4 78 90 19 19 / +33 (0) 4 72 79 05 70  
Adresses e-mail : sales@tecofi.fr ; tecofi@tecofi.fr / Site web : [www.tecofi.fr](http://www.tecofi.fr)