

Ref. : BS 5379BSP pas

Rev. : B

Date : 19/03/2020

Page : 1/1

3PIECES FULL BORE BALL VALVE PN63

BS 5379BSP



APPLICATION

General use : Compatible with common fluids of 2nd group.

GENERAL CHARACTERISTICS

From DN1/4" to DN 4".
Full bore.
Anti blowing-out stem.
PTFE packing.
Locking device.
Stem extension in stainless steel 304 (option).
Black phosphated finish, thickness 5 microns.

CONSTRUCTION

17	Handle cover	PVC
16	Handle	Stainless steel 304
15	Locking device	Inox 304
14	Packing	PTFE
13	Stud nut	Stainless steel 304
12	Stud washer	Stainless steel 304
11	Stud	Stainless steel 304
10	Thrust washer	PTFE
9	Packing gland	Stainless steel 304
8	Handle washer	Stainless steel 304
7	Packing nut	Stainless steel 304
6	Stem	Stainless steel 304
5	Seat	PTFE chargé 15% verre
4	Body gasket	PTFE
3	Ball	Stainless steel 304
2	Ends	ASTM A216 WCB
1	Body	ASTM A216 WCB
Pos.	Description	Material

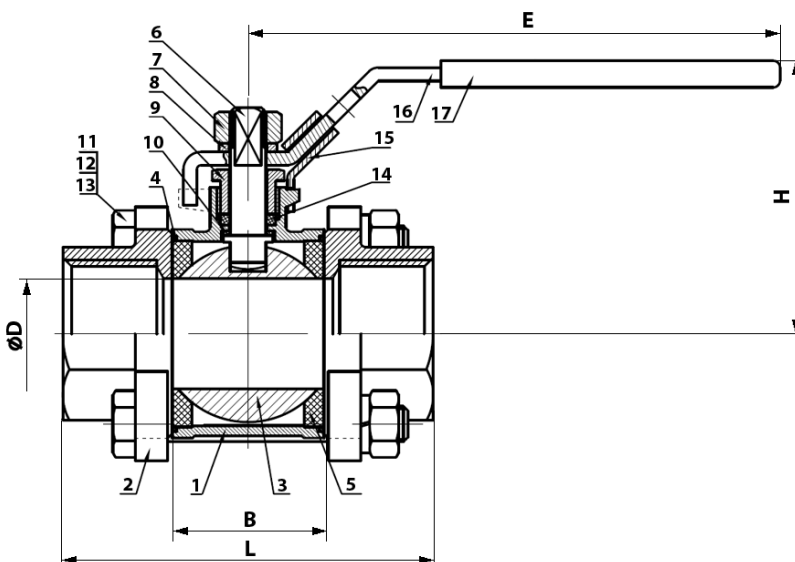
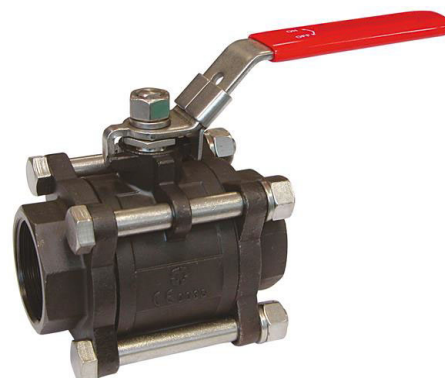

DIMENSIONS

DN		L	ØD	B	E	H	ØY	C	ØT	T1	W	kvs (m3/h)	Torque (Nm)	Weight (kg)
mm	inch													
8	1/4"	59	11,6	21,1	103	49	M8	5	38,5	51	18	12,4	4	0,30
10	3/8"	59	12,5	21,1	103	49	M8	5	38,5	51	21	24,01	4	0,30
15	1/2"	63,3	15	23,3	126	57	M8	5	43	57,5	26	33	8	0,45
20	3/4"	70,6	20	28,6	126	62	M8	5	61,5	66	32	58,6	8	0,60
25	1"	82	25	34	162	72	M8	6,5	58	74,5	39	91,6	10	0,86
32	1 1/4"	97	32	44	162	78	M10	6,5	70	86,5	48	148,2	13	1,32
40	1 1/2"	109	38	51	193	91	M10	8,5	81,5	100,5	55	211,6	20	2,03
50	2"	124,6	50	63	193	102	M12	8,5	101	121,5	67	366,4	20	3,19
65	2 1/2"	162	64	84,3	230	122	M14	9,8	136	161	83	619,2	35	7,06
80	3"	175	76	94,7	230	132	M14	9,8	157	185	99	938	45	10,70
100	4"	216	100	119,2	320	177	M20	16	195,5	226,5	127	1465,6	65	20,95

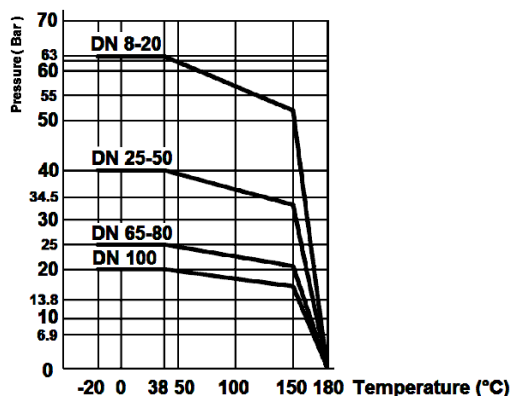
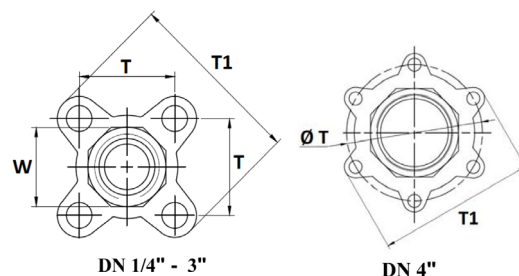

WORKING CONDITIONS

Maximum working temperature : -20°C / + 180°C
Maximum working pressure : depends on DN

STANDARDS

Fabrication according to ISO 9001: 2008.
Pressure tests according to EN 12266-1, range A.
Threaded BSP connection according to ISO 228.1.

TECOFI France - 83, Rue Marcel Mérieux 69960 Corbas - FRANCE
Tél. +33 (0) 4 72 79 05 79 - Fax +33 (0) 4 78 90 19 19 / +33 (0) 4 72 79 05 70
Adresses e-mail : sales@tecofi.fr ; tecofi@tecofi.fr / Site web : www.tecofi.fr