

Ref. : BS 5190

Rev. : initial

Date : 20/04/2015

Page : 1/1

HIGH PRESSURE BALL VALVE

BS 5190



Tecofi
VALVE DESIGNER - FRANCE

APPLICATION

General use : For all common fluids.

GENERAL CHARACTERISTICS

Range from DN1/4" to DN2".
Reduced bore.
Galvanized steel.
High pressure.
Hydraulic type.

CONSTRUCTION

15	Handle screw	Steel DIN 6921 8.8	Steel ISO 4017 8.8
14	Handle washer	Steel 1.0116	Steel 1.0737
13	Handle	Aluminium	Steel 1.0116
12	Seeger	Steel 1.4301	Steel 1.4301
11	Washer	Steel 1.0116	Steel 1.0116
10	O-ring	NBR	NBR
9	Stem seal	POM	POM
8	Stem	Steel 1.0737	Steel 1.0737
7	Spine	Steel 1.0737	Steel 1.0737
6	Caps	PVC	PVC
5	Ends	Galvanized 1.0737 steel	Steel 1.0570
4	O-ring	NBR	NBR
3	Seat	POM	POM
2	Ball	Chromed 1.0737 steel	Chromed 1.0737 steel
1	Body	Galvanized 1.0737 steel	Steel 1.0570
Pos.	Description	DN1/4"-1"1/4	DN1"1/2 - 2"
		Material	

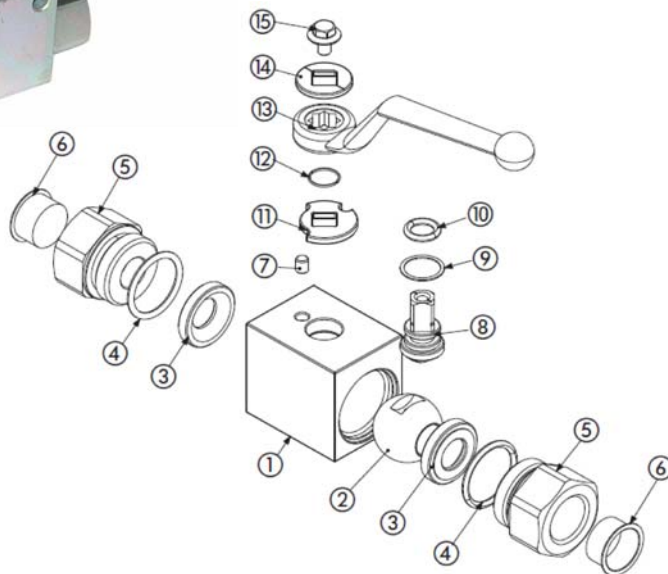

DIMENSIONS

DN		L	L1	Ø	A	B	E	H	T	CH	G	ØR	Weight (kg)
mm	inch												
8	1/4"	71	15.5	6	35	14.5	110	91.5	34	24	30	5.25	0.49
12	3/8"	73	15.5	10	40	17.4	110	96.5	34	30	35	5.25	0.644
15	1/2"	83	17	13	43	18	110	99.5	36	32	37	5.25	0.757
20	3/4"	95	21	20	55	23.4	180	106.5	50	41	45	6.25	1.438
25	1"	112	24	25	65	29.5	180	116.5	50	50	55	6.25	2.223
32	1" 1/4	120	24	25	65	29.5	180	116.5	50	55	55	6.25	2.273
40	1" 1/2	131	25	40	107	53.5	300	134.5	-	75	102	-	7.39
50	2"	140	27	50	114	57	300	141.5	-	85	118	-	9.05

WORKING CONDITIONS

Maximum temperature : -10°C / 100°C

Maximum working pressure: 500 bar - DN1/4" - DN1"1/4
315 bar - DN1"1/2 - 2"

STANDARDS

Fabrication according to ISO 9001 : 2008

Tests according to API 598

Threaded cylindrical BSP ends according to ISO 228-1

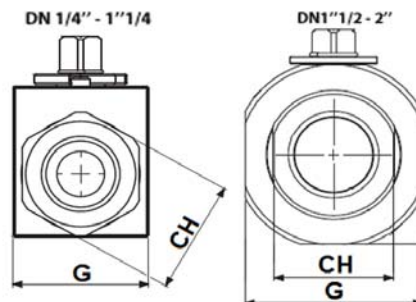
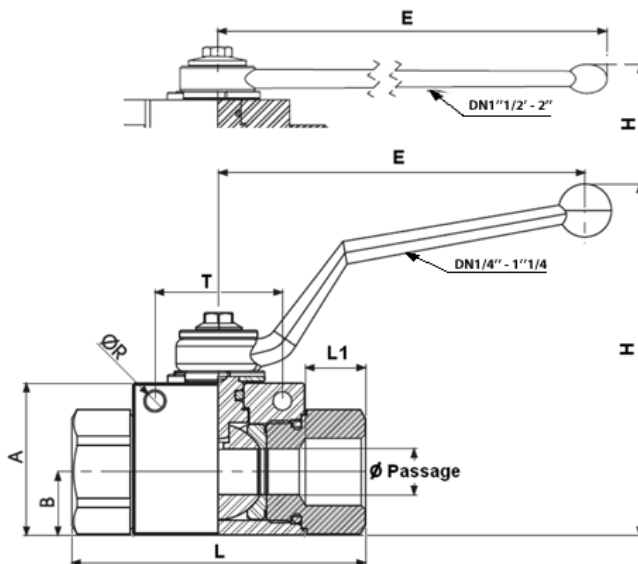

TECOFI France - 83, Rue Marcel Mérieux 69960 Corbas - FRANCE
Tél. +33 (0) 4 72 79 05 79 - Fax +33 (0) 4 78 90 19 19 / +33 (0) 4 72 79 05 70
Adresses e-mail : sales@tecofi.fr ; tecofi@tecofi.fr / Site web : www.tecofi.fr