

Ref. : BS5143NPT

Rev. : Initial

Date : 20/01/2015

Page : 1/1

FORGED STEEL 3 PIECES BALL VALVE 800LBS

BS5143NPT



APPLICATION

General use: Chemical and pharmaceutical industries, petrochemical industries, hydraulic installation, compressed air.

GENERAL CHARACTERISTICS

Full bore
Anti blow-out stem
Packing with elastic rings. Double tightness on stem by PTFE filled with 25% glass fiber packing and FKM O ring. Double tightness between body and ends by FKM O ring and graphite gasket
Antistatic device. Fire safe according to API 607 version 4. Atex
With ISO 5211 mounting pad. Fully encapsulated bolts
800 lbs



CONSTRUCTION

17	Bolting	ASTM A193 B7
16	Stop Pin	Zinc plated steel 8.8
15	Nut	ASTM A582 303
14	ID plate	Aluminium
13	Handle	Zinc plated steel
12	Elastic ring	Stainless steel 301
11	Gland	Stainless steel 316
10	Packing	Graphite
9	O ring	FKM
8	Thrust washer	PTFE filled with 25% glass
7	Seat	PTFE filled with 15% glass
6	O ring	FKM
5	Body gasket	Graphite
4	Stem	ASTM A479 316
3	Ball	ASTM A479 316
2	Ends	ASTM A105N
1	Body	ASTM A105N
Pos.	Description	Material

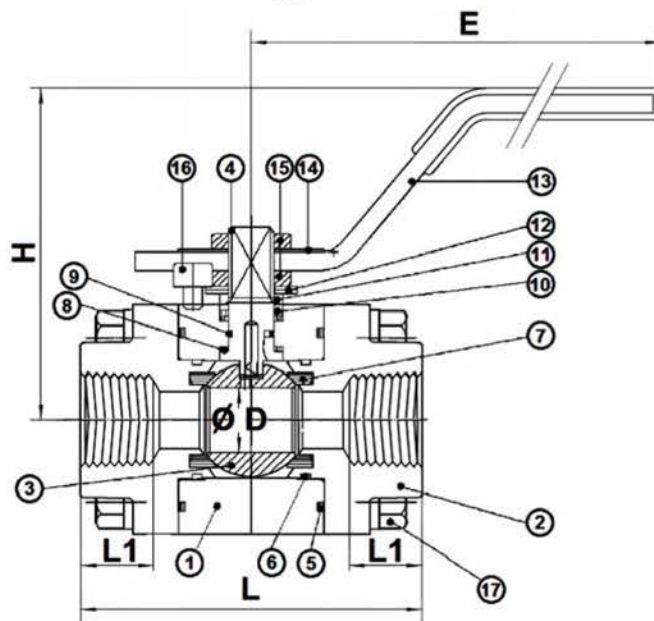

DIMENSIONS

DN	L	H	ØD	E	L1	Stem and ISO plate dimensions							Weight (kg)	
						H1	H2	C	ØY	ØK	ISO	Nx ØZ		
15	1/2"	75	76	14	155	21.5	15.5	9	5.4	10(M10x1.5)	36	F03	4xM5	1
20	3/4"	87	98	20.5	170	27.5	23	14	7.5	12(M12x1.5)	36	F03	4xM5	2.2
25	1"	110	100	25	170	37	25	11	7.5	12(M12x1.5)	42	F04	4xM5	3.1
32	1"1/4	120	20	32.5	230	37	39	16.5	8.9	14(M14x1.5)	50	F05	4xM5	4.8
40	1"1/2	140	130	38	230	44	38	10	8.9	14(M14x1.5)	50	F05	4xM5	6.8
50	2"	160	150	51	310	49	28.3	20	14	20(M20x1.5)	70	F07	4xM5	10.7

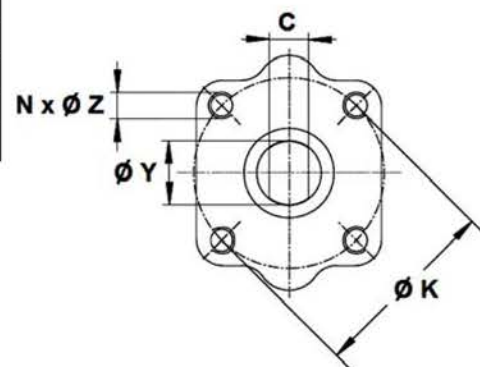
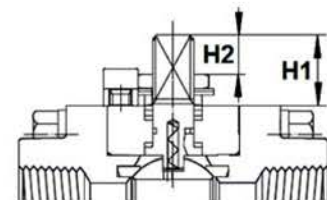

WORKING CONDITIONS

Maximum working pressure : 138 bar
(16 bar maxi for steam).

Maximum working temperature : -29°C/+220°C.

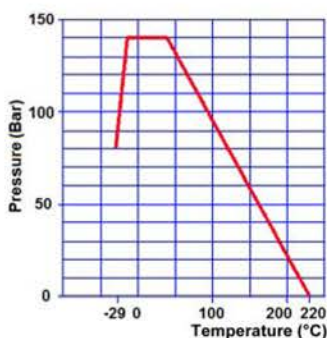

AGREMENT ET NORMES

Fabrication according to ISO 9001 : 2008
DIRECTIVE 2014/68/UE. Risk category III module H
Construction according to ISO 17292
Designing according to ASME B16.34. Tests according to API 598
Fire safe according to API 607 version 4
Threaded NPT ends according to ANSI B1.20.1
ISO 5211 mounting pad

TECOFI France - 83, Rue Marcel Mérieux 69960 Corbas - FRANCE
Tél. +33 (0) 4 72 79 05 79 - Fax +33 (0) 4 78 90 19 19 / +33 (0) 4 72 79 05 70
Adresses e-mail : sales@tecofi.fr ; tecofi@tecofi.fr / Site web : www.tecofi.fr

The photographs and technical art works are not contractual. The specifications of the presented products are open to modifications without previous advice.