

# La vanne à guillotine notre ADN

Knife gate valve, our DNA



**Tecofi est le leader  
mondial de la  
fabrication de  
vannes à guillotine**

Tecofi is the world leader  
in knife gate valves



# VANNE À GUILLOTINE

## KNIFE GATE VALVE

**FONTE DUCTILE**  
**DUCTILE IRON**

**93 > 102**

**INOX**  
**STAINLESS STEEL**

**103 > 110**

**VGB**  
**BI-DIRECTIONNELLE**  
**BIDIRECTIONAL**

**111 > 112**

**VGT**  
**PELLE TRAVERSANTE**  
**THROUGH TYPE**

**113**

**VGS**  
**SOUS SILO**  
**UNDER SILO**

**114**

**MANCHON / HAUTE**  
**PRESSION | PINCH &**  
**HIGH PRESSURE**

**115**

**KIT POUR VG**  
**KIT FOR KGV**

**116 > 139**

**VANNE MURALE**  
**PENSTOCK VALVE**

**140 > 145**

**CONSEILS TECHNIQUES**  
**TECHNICAL NOTES**

**146 > 153**

# VANNE À GUILLOTINE

KNIFE GATE VALVE | DN 50-1200 - PN10

## FOURREAU DE PROTECTION DE TIGE

Tige inox  
*Stem protection tube*  
Stainless steel rising-stem valve



## GRAISSEUR INOX

Stainless steel greaser

## PLAQUES-SUPPORT PRÉFORMÉES

Pre-shaped parts

## PRÉPÉRÇAGE

Pour montage d'accessoires  
*Pilot hole for mounting accessories*

## BOULONNERIE INOX A2

A2 Stainless steel bolts

## CORPS MONOBLOC FONTE DUCTILE

Évite les fuites  
Fonte GGG50 grande résistance aux déformations et à l'abrasion.  
Peinture époxy cuite au four mini 150µm.  
*GGG50 Ductile Iron one piece body*  
Prevents leakage.  
Strong resistance to deformations and abrasions.  
150 micron oven backed epoxy.

## VOLANT FONTE GRISE INCASSABLE

Unbreakable cast iron handwheel

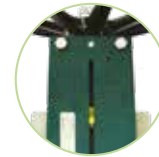

## INDICATEUR DE POSITION

(option)  
Position indicator



## FOULOIR DE PRESSE ÉTOUPE BOULONNÉ AVEC ECROU NYLSTOP

Resserrable en service, pas de desserrage possible si vibration  
*Bolted packing gland*  
Retightening possible while in operation, untightening not possible in the case of vibrations

## PELLE TRANCHANTE

Usinée et polie  
*Beveled gate*  
Machined and polished

## JOINT MOULÉ ÉLASTOMÈRE ET PROFILÉ A TALON

Arrachement du siège impossible  
*Gasket seat wrenching not possible*  
*Heel-shaped molded rubber gasket*

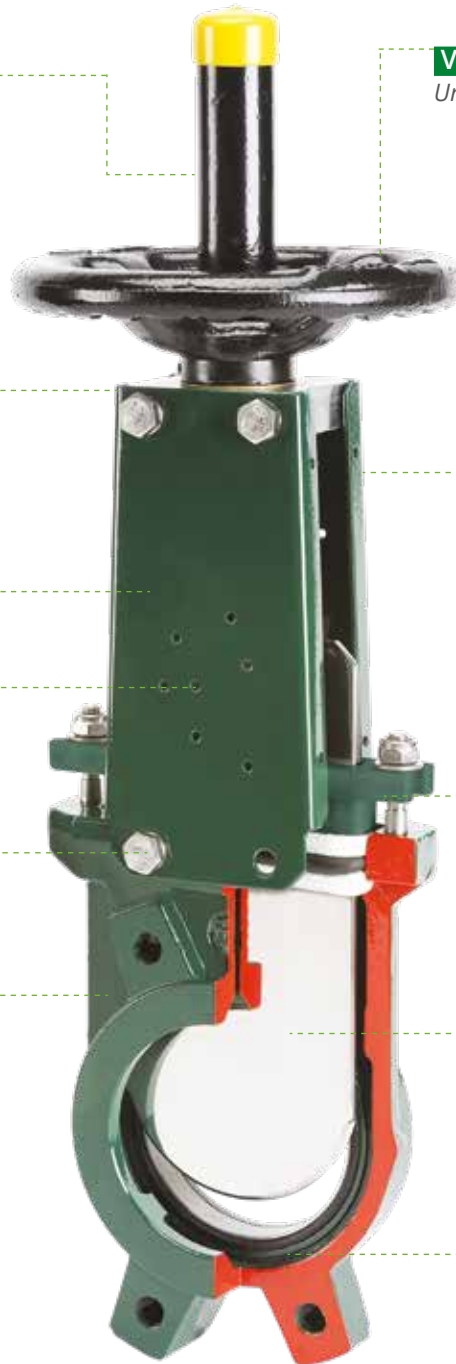

## VANNES À GUILLOTINE

Les vannes à guillotine TECOFI sont particulièrement adaptées pour les applications les plus difficiles (traitement d'eau, papeterie, biogaz, vinicole, cimenterie, usines chimiques).

Constituée d'une pelle chanfreinée coupante, la vanne à guillotine permet la pénétration dans le produit sans blocage. Le fouloir de presse étoupe en fonte ductile est très résistant, et la garniture de presse étoupe offre élasticité à l'ensemble et permet de réduire les efforts de manœuvre.

TECOFI propose de nombreuses options pour répondre à toutes les contraintes des utilisateurs (contacts fin de course, capots de protection, traitement de pelle spécifique...)

## KNIFE GATE VALVES

TECOFI knife gate valve are particularly suitable for the most difficult applications (water treatment networks, the pulp and paper industry, biogas, winemaking, cement works, chemical plants).

The gate is sharp thanks to its beveled edge, facilitating the gate to cut the product without any blockage. The very resistant ductile iron packing gland and the material of the gasket offer more elasticity to the assembly, reducing the operating force.

TECOFI offers many options to meet all user needs (mechanical limit switches, inductive sensor protection, specifically treated gate, etc).

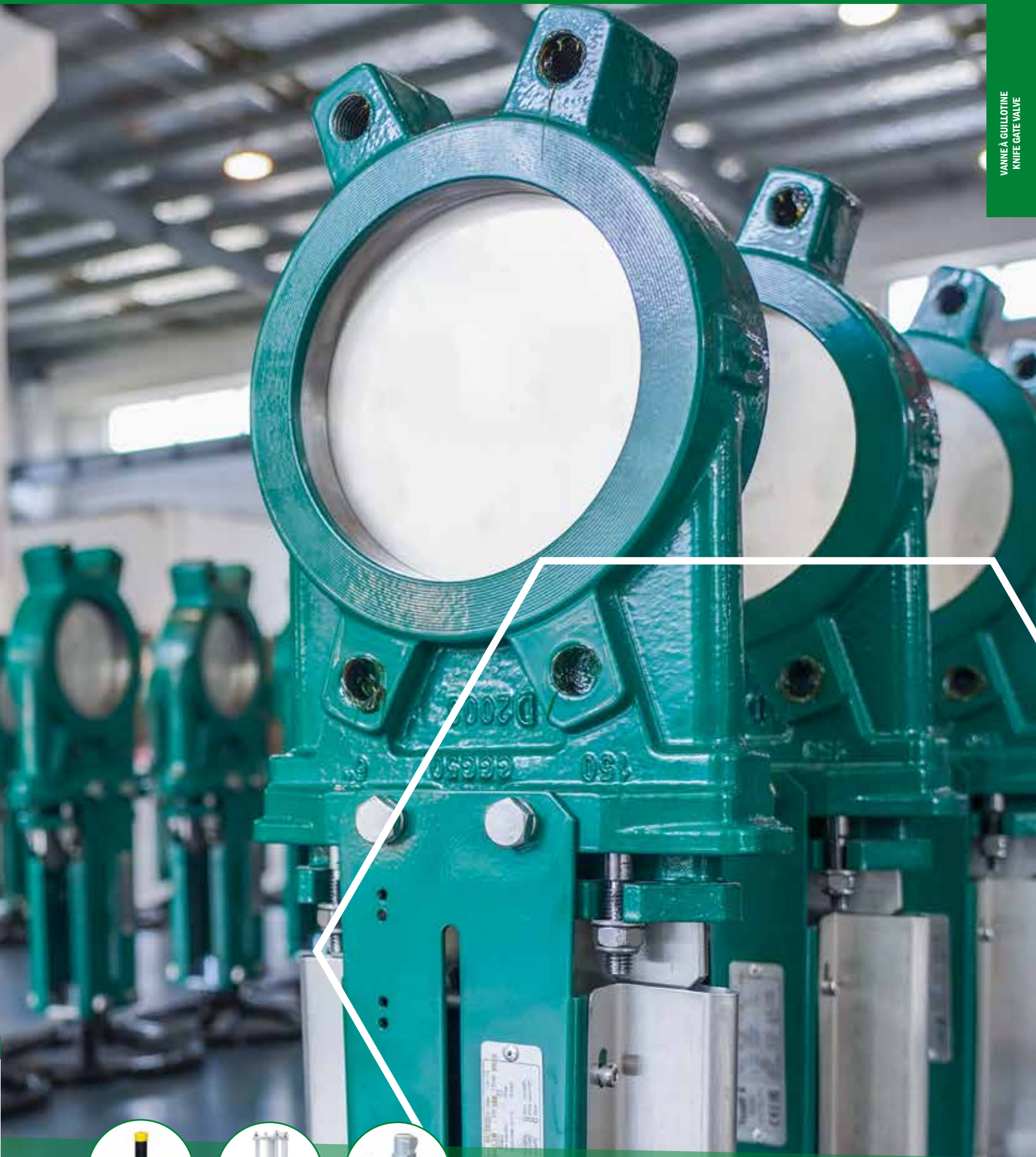

## GAMME COMPLÈTE *Full Range*



VANNE A GUILLOTINE STANDARD - FONTE DUCTILE  
STANDARD KNIFE GATE VALVE - DUCTILE IRON



VANNE À GUILLOTINE  
KNIFE GATE VALVE



ÉVOLUTION DE GAMME !

Corps fonte ductile standardisé

TECOFI adapte sa gamme aux contraintes mécaniques subies par ses vannes et vous propose désormais toutes les vannes à guillotine avec un **corps en fonte ductile (GS)**, parfaitement adapté aux industries lourdes (cimenterie, traitement de déchets...).

Robuste, la fonte ductile possède des propriétés mécaniques améliorées lui procurant une meilleure résistance aux chocs ainsi qu'une meilleure tenue aux vibrations et à l'abrasion.

UPDATED RANGE!

Standard Ductile Iron Body

TECOFI is adapting its range to meet the mechanical strains its valves face, offering from now on all knife gate valves with **ductile iron** bodies, perfectly suitable for heavy industries (cement factories, waste treatment, etc.). Robust, ductile iron has improved mechanical properties, which permits better impact, vibration and abrasion resistance.

VG4400-00NI | VG4400-00MM | VG4400-00EA

Tige montante | Rising-stem

Vanne à guillotine fonte ductile à tige montante et à volant

Ductile iron rising-stem knife gate valve with handwheel



Corps : Fonte ductile EN-GJS-500-7 (GGG50)  
Pelle : Inox 304  
Presse Etoupe : 2 tresses PTFE + 1 torique NBR  
Raccordement : Entre-brides PN10  
Pression de service :  
DN50-250 : 10 bar  
DN300-450 : 7 bar  
DN500-600 : 4 bar  
Température de service : -10°C/+ 80°C  
Plaques support acier préformées permettant l'adaptation d'accessoires

Body: Ductile iron EN-GJS-500-7 (GGG50)  
Gate: Stainless steel 304  
Packing: 2 PTFE packing + 1 NBR O-ring  
Connection: Between flanges PN10  
Working pressure:  
DN50-250: 10 bar  
DN300-450: 7 bar  
DN500-600: 4 bar  
Working temperature: -10°C/+ 80°C  
Pre-shaped parts for accessories

Réducteur conseillé  
> DN450  
Gearbox is  
recommended  
> DN450

DN		L (mm)	Kg	Etanchéité : Nitrile Seat: Nitrile	Etanchéité : Métal/ Métal Seat: Metal/Metal
mm	inch			Ref.	Ref.
50	2"	40	7,5	VG4400-00NI0050	VG4400-00MM0050
65	2 1/2"	40	9	VG4400-00NI0065	VG4400-00MM0065
80	3"	50	10	VG4400-00NI0080	VG4400-00MM0080
100	4"	50	11,5	VG4400-00NI0100	VG4400-00MM0100
125	5"	50	15,5	VG4400-00NI0125	VG4400-00MM0125
150	6"	60	18,5	VG4400-00NI0150	VG4400-00MM0150
200	8"	60	35	VG4400-00NI0200	VG4400-00MM0200
250	10"	70	47	VG4400-00NI0250	VG4400-00MM0250
300	12"	70	61	VG4400-00NI0300	VG4400-00MM0300
350	14"	96	117	VG4400-00NI0350	VG4400-00MM0350
400	16"	100	151	VG4400-00NI0400	VG4400-00MM0400
450	18"	106	187	VG4400-00NI0450	VG4400-00MM0450
500	20"	110	205	VG4400-00NI0500	VG4400-00MM0500
600	24"	110	292	VG4400-00NI0600	VG4400-00MM0600



ATEX sur demande  
ATEX on request



Optez pour la version ACS, pour vos applications sur eau potable !

Order ACS version for your drinking water applications!



Corps : Fonte ductile EN-GJS-500-7 (GGG50)  
Pelle : Inox 316L  
Peinture corps : Bleu ACS RAL5015  
Joint : EPDM ACS  
Tresse : PTFE compatible eau potable  
Raccordement : Entre-brides PN10  
Pression de service :  
DN50-250 : 10 bar  
DN300-450 : 7 bar  
DN500-600 : 4 bar  
Température de service : -10°C/+ 80°C  
Plaques support acier préformées permettant l'adaptation d'accessoires

Body: Ductile iron EN-GJS-500-7 (GGG50)  
Gate: Stainless Steel 316L  
Body coating: Blue ACS RAL5015  
Seal: EPDM ACS  
Packing: PTFE suitable potable water  
Connection: Between flanges PN10  
Working pressure:  
DN50-250: 10 bar  
DN300-450: 7 bar  
DN500-600: 4 bar  
Working temperature: -10°C/+ 80°C  
Pre-shaped parts for accessories

DN		L (mm)	Kg	EPDM ACS	
mm	inch			Ref.	Ref.
50	2"	40	7,5	VG4400-00EA0050	
65	2 1/2"	40	9	VG4400-00EA0065	
80	3"	50	10	VG4400-00EA0080	
100	4"	50	11,5	VG4400-00EA0100	
125	5"	50	15,5	VG4400-00EA0125	
150	6"	60	18,5	VG4400-00EA0150	
200	8"	60	35	VG4400-00EA0200	
250	10"	70	47	VG4400-00EA0250	
300	12"	70	61	VG4400-00EA0300	
350	14"	96	117	VG4400-00EA0350	
400	16"	100	151	VG4400-00EA0400	
450	18"	106	187	VG4400-00EA0450	
500	20"	110	205	VG4400-00EA0500	
600	24"	110	292	VG4400-00EA0600	





Ductile Iron body

## VGA4430-00EP

## ASA150 Tige montante | Rising-stem

Vanne à guillotine fonte ductile à tige montante et à volant- ASA 150  
Ductile iron rising-stem knife gate valve with handwheel - ASA 150



Corps : Fonte ductile EN-GJS-500-7 (GGG50)  
Pelle : Inox 304  
Siège : EPDM  
Presse Etoupe : 2 tresses PTFE + 1 torique EPDM  
Raccordement : ASA150  
Pression de service :  
DN50-250 : 10 bar  
DN300-450 : 7 bar  
DN500-600 : 4 bar  
Température de service : -10°C/+130°C

Body: Ductile iron EN-GJS-500-7 (GGG50)  
Gate: Stainless steel 304  
Seat: EPDM  
Packing: 2 PTFE packing + 1 EPDM O-ring  
Connection: ASA150  
Working pressure:  
DN50-250: 10 bar  
DN300-450: 7 bar  
DN500-600: 4 bar  
Maximum Working temperature: -10°C/+130°C

DN		L (mm)	Kg	Etanchéité : EPDM Seat: EPDM
mm	inch			
50	2"	40	7,5	VGA4430-00EP0050
65	2"1/2	40	9	VGA4430-00EP0065
80	3"	50	10	VGA4430-00EP0080
100	4"	50	11,5	VGA4430-00EP0100
125	5"	50	15,5	VGA4430-00EP0125
150	6"	60	18,5	VGA4430-00EP0150
200	8"	60	35	VGA4430-00EP0200
250	10"	70	47	VGA4430-00EP0250
300	12"	70	61	VGA4430-00EP0300
350	14"	96	117	VGA4430-00EP0350
400	16"	100	151	VGA4430-00EP0400
450	18"	106	187	VGA4430-00EP0450
500	20"	110	205	VGA4430-00EP0500
600	24"	110	292	VGA4430-00EP0600

Autre type de siège sur demande  
Other seat type on request



**Ex** ATEX sur demande  
ATEX on request



Voir kit cadenassable page 117  
See locking kit on page 117





Ductile Iron body

VG4400-001NI | VG4400-001MM | VG4400-001EA **Tige non montante | Non-rising stem**

Vanne à guillotine fonte ductile à tige non montante et à volant  
Ductile iron non-rising stem knife gate valve with handwheel



**Encombrement optimisé en hauteur**  
Height-optimized dimensions



Corps : Fonte ductile EN-GJS-500-7 (GGG50)  
Pelle : Inox 304  
Presse Etoupe : 2 tresses PTFE + 1 torique NBR  
Raccordement : Entre-brides PN10  
Pression de service :  
DN50-250 : 10 bar  
DN300-450 : 7 bar  
DN500-600 : 4 bar  
Température de service : -10°C/+80°C  
Plaques support acier préformées permettant l'adaptation d'accessoires

Body: Ductile Iron EN-GJS-500-7 (GGG50)  
Gate: Stainless steel 304  
Packing: 2 PTFE packing + 1 NBR O-ring  
Connection: Between flanges PN10  
Working pressure:  
DN50-250: 10 bar  
DN300-450: 7 bar  
DN500-600: 4 bar  
Working temperature: -10°C/+80°C  
Pre-shaped parts for accessories



ATEX sur demande  
ATEX on request

DN		L (mm)	Kg	Etanchéité : Nitrile	Etanchéité : Métal/
mm	inch			Seat: Nitrile	Métal
				Ref.	Ref.
50	2"	40	7,5	VG4400-001NI0050	VG4400-001MM0050
65	2"1/2	40	8,8	VG4400-001NI0065	VG4400-001MM0065
80	3"	50	9,4	VG4400-001NI0080	VG4400-001MM0080
100	4"	50	11,5	VG4400-001NI0100	VG4400-001MM0100
125	5"	50	15,4	VG4400-001NI0125	VG4400-001MM0125
150	6"	60	18,5	VG4400-001NI0150	VG4400-001MM0150
200	8"	60	34,8	VG4400-001NI0200	VG4400-001MM0200
250	10"	70	47	VG4400-001NI0250	VG4400-001MM0250
300	12"	70	61	VG4400-001NI0300	VG4400-001MM0300
350	14"	96	117	VG4400-001NI0350	VG4400-001MM0350
400	16"	100	151	VG4400-001NI0400	VG4400-001MM0400
450	18"	106	187	VG4400-001NI0450	VG4400-001MM0450
500	20"	110	205	VG4400-001NI0500	VG4400-001MM0500
600	24"	110	292	VG4400-001NI0600	VG4400-001MM0600



Optez pour la version ACS, pour vos applications sur eau potable !

Order ACS version for your drinking water applications!

**ACS**



Corps : Fonte ductile EN-GJS-500-7 (GGG50)  
Pelle : Inox 316L  
Peinture corps : Bleu ACS RAL5015  
Joint : EPDM ACS  
Tresse : PTFE compatible eau potable  
Raccordement : Entre-brides PN10  
Pression de service :  
DN50-250 : 10 bar  
DN300-450 : 7 bar  
DN500-600 : 4 bar  
Température de service : -10°C/+80°C  
Plaques support acier préformées permettant l'adaptation d'accessoires

Body: Ductile iron EN-GJS-500-7 (GGG50)  
Gate: Stainless steel 316L  
Body coating: Blue ACS RAL5015  
Seal: EPDM ACS  
Packing: PTFE suitable potable water  
Connection: Between flanges PN10  
Working pressure:  
DN50-250: 10 bar  
DN300-450: 7 bar  
DN500-600: 4 bar  
Working temperature: -10°C/+80°C  
Pre-shaped parts for accessories

DN		L (mm)	Kg	EPDM ACS
mm	inch			Ref.
50	2"	40	7,5	VG4400-001EA0050
65	2"1/2	40	8,8	VG4400-001EA0065
80	3"	50	9,4	VG4400-001EA0080
100	4"	50	11,5	VG4400-001EA0100
125	5"	50	15,4	VG4400-001EA0125
150	6"	60	18,5	VG4400-001EA0150
200	8"	60	34,8	VG4400-001EA0200
250	10"	70	47	VG4400-001EA0250
300	12"	70	61	VG4400-001EA0300
350	14"	96	117	VG4400-001EA0350
400	16"	100	151	VG4400-001EA0400
450	18"	106	187	VG4400-001EA0450
500	20"	110	205	VG4400-001EA0500
600	24"	110	292	VG4400-001EA0600





Ductile Iron body

**VG4400-051NI | VG4400-051MM**

**Commande par carré de manœuvre | Square operating**

Vanne à guillotine fonte ductile tige non montante et à carré de manœuvre  
Ductile iron non-rising stem knife gate valve with square operating

Etanchéité : Nitrile Seat: Nitrile		Etanchéité : Métal/ Métal Seat: Metal/Metal	
mm	inch	Ref.	Ref.

DN		L (mm)	Kg	Ref.	Ref.
mm	inch				
50	2"	40	6,5	VG4400-051NI0050	VG4400-051MM0050
65	2"1/2	40	7,8	VG4400-051NI0065	VG4400-051MM0065
80	3"	50	8,4	VG4400-051NI0080	VG4400-051MM0080
100	4"	50	10,5	VG4400-051NI0100	VG4400-051MM0100
125	5"	50	14,4	VG4400-051NI0125	VG4400-051MM0125
150	6"	60	17,5	VG4400-051NI0150	VG4400-051MM0150
200	8"	60	32,8	VG4400-051NI0200	VG4400-051MM0200
250	10"	70	45	VG4400-051NI0250	VG4400-051MM0250
300	12"	70	59	VG4400-051NI0300	VG4400-051MM0300
350	14"	96	114	VG4400-051NI0350	VG4400-051MM0350
400	16"	100	148	VG4400-051NI0400	VG4400-051MM0400
450*	18"	106	184	VG4400-051NI0450	VG4400-051MM0450

\*Manœuvre manuelle non recommandée à partir du DN450  
Manual operation not recommended from DN450 and up



Corps : Fonte ductile EN-GJS-500-7 (GGG50)  
Pelle : Inox 304  
Presse Etoupe : 2 tresses PTFE + 1 torique NBR  
Raccordement : Entre-bridés PN10  
Pression de service :  
DN50-250 : 10 bar  
DN300-450 : 7 bar  
DN500 : 4 bar  
Température de service : -10°C/+80°C

Body: Ductile Iron EN-GJS-500-7 (GGG50)  
Gate: Stainless steel 304  
Packing: 2 PTFE packing + 1 NBR O-ring  
Connection: Between flanges PN10  
Working pressure:  
DN50-250: 10 bar  
DN300-450: 7 bar  
DN500: 4 bar  
Working temperature: -10°C/+80°C



ATEX sur demande  
ATEX on request



**Vanne idéale pour montage avec colonnette droite et murale ou installées dans un regard.**  
Voor pages 135-136  
**Valve ideal for column or wall mounting or installed in a manhole.** See on pages 135-136



**Voir carré seul page 116**  
See ref square page 116



**VG4400-02NI | VG4400-02MM**

**Commande par levier | Lever operating**

Vanne à guillotine fonte ductile à levier  
Ductile iron knife gate valve lever operating



**Ouverture et fermeture rapide**  
For quick opening and closing

Etanchéité : Nitrile Seat: Nitrile		Etanchéité : Métal/ Métal Seat: Metal/Metal	
mm	inch	Ref.	Ref.

DN		L (mm)	Kg	Ref.	Ref.
mm	inch				
50	2"	40	7,5	VG4400-02NI0050	VG4400-02MM0050
65	2"1/2	40	7,8	VG4400-02NI0065	VG4400-02MM0065
80	3"	50	8,4	VG4400-02NI0080	VG4400-02MM0080
100	4"	50	11,5	VG4400-02NI0100	VG4400-02MM0100
125	5"	50	14,4	VG4400-02NI0125	VG4400-02MM0125
150	6"	60	18,5	VG4400-02NI0150	VG4400-02MM0150
200	8"	60	28,8	VG4400-02NI0200	VG4400-02MM0200
250*	10"	70	41	VG4400-02NI0250	VG4400-02MM0250
300*	12"	70	58	VG4400-02NI0300	VG4400-02MM0300

\*Manœuvre plus difficile à partir du DN250 | Please note: more difficult to operate from DN250 and up



Corps : Fonte ductile EN-GJS-500-7 (GGG50)  
Pelle : Inox 304  
Presse Etoupe : 2 tresses PTFE + 1 torique NBR  
Raccordement : Entre-bridés PN10  
Pression de service :  
DN50-250 : 10 bar  
DN300 : 7 bar  
Température de service : -10°C/+80°C  
Actionnement de manœuvre rapide par levier

Body: Ductile Iron EN-GJS-500-7 (GGG50)  
Gate: Stainless steel 304  
Packing: 2 PTFE packing + 1 NBR O-ring  
Connection: Between flanges PN10  
Working pressure:  
DN50-250: 10 bar  
DN300: 7 bar  
Working temperature: -10°C/+80°C  
Fast lever actuation



ATEX sur demande  
ATEX on request



**Version (ACS) disponible sur demande**  
ACS model available on request



**Voir kit cadenassable page 117**  
See locking kit page 117







Ductile Iron body

VG4400-03NI | VG4400-03MM | VG4400-03EA

Vérin pneumatique | Pneumatic actuator

Vanne à guillotine fonte ductile à vérin pneumatique double effet  
Ductile iron knife gate valve with double-acting pneumatic actuator

Etanchéité : Nitrile Seat: Nitrile	Etanchéité : Métal/ Métal Seat: Metal/Metal
---------------------------------------	---



**Corps :** Fonte ductile EN-GJS-500-7 (GGG50)  
**Pelle :** Inox 304  
**Presse Etoupe :** DN50-600 = 2 tresses PTFE+ 1 torique NBR  
DN700-800 = 3 tresses PTFE+ 1 torique NBR  
DN900-1200 = 4 tresses PTFE+ 1 torique NBR  
**Raccordement :** Entre-bridés PN10  
**Pression de service :**  
DN50-250 : 10 bar  
DN300-450 : 7 bar  
DN500-600 : 4 bar  
DN700-1200 : 2 bar  
**Température de service :** -10°C/+80°C  
**Capots de protection :** Inox 304  
**Vérin pneumatique double effet 6 bar**

**Body:** Ductile iron EN-GJS-500-7 (GGG50)  
**Gate:** Stainless steel 304  
**Packing:** DN50-600 = 2 PTFE packing + 1 NBR O-ring  
DN700-800 = 3 PTFE packing + 1 NBR O-ring  
DN900-1200 = 4 PTFE packing + 1 NBR O-ring  
**Connection:** Between flanges PN10

**Working pressure:**  
DN50-250: 10 bar  
DN300-450: 7 bar  
DN500-600: 4 bar  
DN700-1200: 2 bar  
**Working temperature:** -10°C/+80°C  
**Protective cover:** Stainless steel 304  
**Double-acting pneumatic actuator 6 bar**

DN		L (mm)	Kg	Ref.	Ref.
mm	inch				
50	2"	40	7,5	VG4400-03NI0050	VG4400-03MM0050
65	2 1/2"	40	7,8	VG4400-03NI0065	VG4400-03MM0065
80	3"	50	8,4	VG4400-03NI0080	VG4400-03MM0080
100	4"	50	12,5	VG4400-03NI0100	VG4400-03MM0100
125	5"	50	16,4	VG4400-03NI0125	VG4400-03MM0125
150	6"	60	20,5	VG4400-03NI0150	VG4400-03MM0150
200	8"	60	35,8	VG4400-03NI0200	VG4400-03MM0200
250	10"	70	52	VG4400-03NI0250	VG4400-03MM0250
300	12"	70	72	VG4400-03NI0300	VG4400-03MM0300
350	14"	96	129	VG4400-03NI0350	VG4400-03MM0350
400	16"	100	144	VG4400-03NI0400	VG4400-03MM0400
450	18"	106	177	VG4400-03NI0450	VG4400-03MM0450
500	20"	110	268	VG4400-03NI0500	VG4400-03MM0500
600	24"	110	351	VG4400-03NI0600	VG4400-03MM0600
700	28"	110	556	VG4400-03NI0700	VG4400-03MM0700
800	32"	110	679	VG4400-03NI0800	VG4400-03MM0800
900	36"	110	804	VG4400-03NI0900	VG4400-03MM0900
1000	40"	120	1053	VG4400-03NI1000	VG4400-03MM1000
1200	40"	130	-	VG4400-03NI1200	VG4400-03MM1200



**Ex** ATEX sur demande  
ATEX on request



Utiliser de l'air comprimé conforme à la classe de pureté ISO 8573-1  
Use compressed air conforming to the purity class ISO 8573-1

Version avec vérin pneumatique simple effet voir page 102  
Version equipped with single-acting pneumatic actuator, see on page 102



Optez pour la version ACS, pour vos applications sur eau potable!

Order ACS version for your drinking water applications!

**ACS**

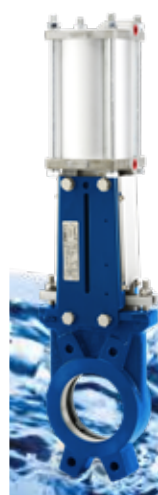

**Corps :** Fonte ductile EN-GJS-500-7 (GGG50)  
**Pelle :** Inox 316L  
**Peinture corps :** Bleu ACS RAL5015  
**Joint :** EPDM ACS  
**Tresse :** PTFE compatible eau potable  
**Raccordement :** Entre-bridés PN10  
**Pression de service :**  
DN50-250 : 10 bar  
DN300-450 : 7 bar  
DN500-600 : 4 bar  
DN700-1200 : 2 bar  
**Température de service :** -10°C/+80°C  
**Capots de protection :** Inox 304  
**Vérin pneumatique double effet 6 bar**

**Body:** Ductile iron EN-GJS-500-7 (GGG50)  
**Gate:** Stainless steel 316L  
**Body coating:** Blue ACS RAL5015  
**Seal:** EPDM ACS  
**Packing:** PTFE suitable potable water  
**Connection:** Between flanges PN10  
**Working pressure:**  
DN50-250: 10 bar  
DN300-450: 7 bar  
DN500-600: 4 bar  
DN700-1200: 2 bar  
**Working temperature:** -10°C/+80°C  
**Protective cover:** Stainless steel 304  
**Double-acting pneumatic actuator 6 bar**

DN		L (mm)	Kg	Ref.	EPDM ACS
mm	inch				Ref.
50	2"	40	7,5	VG4400-03EA0050	
65	2 1/2"	40	7,8	VG4400-03EA0065	
80	3"	50	8,4	VG4400-03EA0080	
100	4"	50	12,5	VG4400-03EA0100	
125	5"	50	16,4	VG4400-03EA0125	
150	6"	60	20,5	VG4400-03EA0150	
200	8"	60	35,8	VG4400-03EA0200	
250	10"	70	52	VG4400-03EA0250	
300	12"	70	72	VG4400-03EA0300	
350	14"	96	129	VG4400-03EA0350	
400	16"	100	144	VG4400-03EA0400	
450	18"	106	177	VG4400-03EA0450	
500	20"	110	268	VG4400-03EA0500	
600	24"	110	351	VG4400-03EA0600	



Ductile Iron body

VGA4430-03EP

ASA150 Vérin pneumatique | Pneumatic actuator

Vanne à guillotine fonte ductile à vérin pneumatique double effet - ASA 150  
Ductile iron knife gate valve with double-acting pneumatic actuator - ASA 150



Corps : Fonte ductile EN-GJS-500-7 (GGG50)  
Pelle : Inox 304  
Siège : EPDM  
Presse Etoupe : 2 tresses PTFE + 1 torique NBR  
Raccordement : ASA150  
Pression de service :  
DN50-250 : 10 bar  
DN300-450 : 7 bar  
Température de service : -10°C/+130°C  
Capots de protection : Inox 304

Body: Ductile Iron EN-GJS-500-7 (GGG50)  
Gate: Stainless steel 304  
Seat: EPDM  
Packing: 2 PTFE packing + 1 NBR O-ring  
Connection: ASA150  
Working pressure:  
DN50-250: 10 bar  
DN300-450: 7 bar  
Working temperature: -10°C/+130°C  
Protective cover: Stainless steel 304

DN		L (mm)	Kg	Etanchéité : EPDM Seat: EPDM.
mm	inch			
50	2"	40	7,5	VGA4430-03EP0050
65	2"1/2	40	7,8	VGA4430-03EP0065
80	3"	50	8,4	VGA4430-03EP0080
100	4"	50	12,5	VGA4430-03EP0100
125	5"	50	16,4	VGA4430-03EP0125
150	6"	60	20,5	VGA4430-03EP0150
200	8"	60	35,8	VGA4430-03EP0200
250	10"	70	52	VGA4430-03EP0250
300	12"	70	72	VGA4430-03EP0300
350	14"	96	129	VGA4430-03EP0350
400	16"	100	144	VGA4430-03EP0400
450	18"	106	177	VGA4430-03EP0450
500	20"	110	205	VGA4430-03EP500
600	24"	110	292	VGA4430-03EP600

Autre type de siège sur demande  
Other seat type on request



ATEX sur demande  
ATEX on request



Utiliser de l'air comprimé conforme à la classe de pureté ISO 8573-1  
Use compressed air conforming to the purity class ISO 8573-1

VG4400-031NI

Commande de secours | Manual emergency control

Vanne à guillotine fonte ductile à vérin pneumatique double effet + commande manuelle de secours  
Ductile iron knife gate valve with double-acting pneumatic actuator + manual emergency control



Corps : Fonte ductile EN-GJS-500-7 (GGG50)  
Pelle : Inox 304  
Presse Etoupe : 2 tresses PTFE + 1 torique NBR  
Raccordement : Entre-brides PN10  
Pression de service :  
DN50-250 : 10 bar  
DN300-450 : 7 bar  
DN500-600 : 4 bar  
Température de service : -10°C/+80°C  
Capot de protection : Inox 304  
Vérin pneumatique double effet 6 bar équipé de commande manuelle de secours

Body: Ductile Iron EN-GJS-500-7 (GGG50)  
Gate: Stainless steel 304  
Packing: 2 PTFE packing + 1 NBR O-ring  
Connection: Between flanges PN10  
Working pressure:  
DN50-250: 10 bar  
DN300-450: 7 bar  
DN500-600: 4 bar  
Working temperature: -10°C/+80°C  
Protective cover: Stainless steel 304  
Double-acting pneumatic actuator 6 bar equipped with manual emergency control

DN		L (mm)	Kg	Etanchéité : Nitrile Seat: Nitrile.
mm	inch			
50	2"	40	10	VG4400-031NI0050
65	2"1/2	40	11	VG4400-031NI0065
80	3"	50	12	VG4400-031NI0080
100	4"	50	15	VG4400-031NI0100
125	5"	50	21	VG4400-031NI0125
150	6"	60	27	VG4400-031NI0150
200	8"	60	45	VG4400-031NI0200
250	10"	70	69	VG4400-031NI0250
300	12"	70	89	VG4400-031NI0300
350	14"	96	153	VG4400-031NI0350
400	16"	100	166	VG4400-031NI0400
450	18"	106	212	VG4400-031NI0450
500	20"	110	251	VG4400-031NI0500
600	24"	110	300	VG4400-031NI0600



ATEX sur demande  
ATEX on request



Utiliser de l'air comprimé conforme à la classe de pureté ISO 8573-1  
Use compressed air conforming to the purity class ISO 8573-1



Voir kit de commande seul page 119  
See control kit on page 119



Ductile Iron body

**VG4400-004NI | VG4400-004MM** **Embase ISO | ISO mounting plate**

Vanne à guillotine fonte ductile à tige montante avec embase ISO pour motorisation électrique  
Ductile iron rising-stem knife gate valve with ISO mounting plate for electric actuator



Corps : Fonte ductile EN-GJS-500-7 (GGG50)  
Pelle : Inox 304  
Embase ISO : Acier A45  
Presse Étoupe : 2 tresses PTFE + 1 torique NBR  
Raccordement : Entre-bridés PN10  
Pression de service :  
DN50-250 : 10 bar  
DN300-450 : 7 bar  
DN500-600 : 4 bar  
Température de service : -10°C/+80°C

Body: Ductile Iron EN-GJS-500-7 (GGG50)  
Gate: Stainless steel 304  
ISO plate : Steel A45  
Packing: 2 PTFE packing + 1 NBR O-ring  
Connection: Between flanges PN10  
Working pressure:  
DN50-250: 10 bar  
DN300-450: 7 bar  
DN500-600: 4 bar  
Working temperature: -10°C/+80°C



**Ex** ATEX sur demande  
ATEX on request

				Etanchéité : Nitrile Seat: Nitrile	Etanchéité : Métal/ Métal Seat: Metal/Metal
DN			Kg	Ref.	Ref.
mm	inch				
50	2"	40	6	VG4400-004NI0050	VG4400-004MM0050
65	2 1/2"	40	8	VG4400-004NI0065	VG4400-004MM0065
80	3"	50	9	VG4400-004NI0080	VG4400-004MM0080
100	4"	50	10	VG4400-004NI0100	VG4400-004MM0100
125	5"	50	15	VG4400-004NI0125	VG4400-004MM0125
150	6"	60	19	VG4400-004NI0150	VG4400-004MM0150
200	8"	60	33	VG4400-004NI0200	VG4400-004MM0200
250	10"	70	47	VG4400-004NI0250	VG4400-004MM0250
300	12"	70	58	VG4400-004NI0300	VG4400-004MM0300
350	14"	96	107	VG4400-004NI0350	VG4400-004MM0350
400	16"	100	137	VG4400-004NI0400	VG4400-004MM0400
450	18"	106	177	VG4400-004NI0450	VG4400-004MM0450
500	20"	110	212	VG4400-004NI0500	VG4400-004MM0500
600	24"	110	256	VG4400-004NI0600	VG4400-004MM0600

Pour DN supérieur, voir vannes avec réducteur motorisable  
Other DN, please check the valve stem gearbox actuator operating

**Version (ACS) disponible sur demande**  
ACS model available on request

**VG4400-08NI | VG4400-08MM** **Réducteur manuel | Gearbox actuator**

Vanne à guillotine fonte ductile à tige montante à réducteur manuel  
Ductile iron knife gate valve rising-stem with gearbox actuator operating



Avec platine de motorisation sur réducteur  
With motorization plate on reducer





Corps : Fonte ductile EN-GJS-500-7 (GGG50)  
Pelle : Inox 304  
Presse Étoupe :  
DN50-600 = 2 tresses PTFE+ 1 torique NBR  
DN700-800 = 3 tresses PTFE+ 1 torique NBR  
DN900-1200 = 4 tresses PTFE+ 1 torique NBR  
Raccordement : Entre-bridés PN10  
Pression de service :  
DN350-450 : 7 bar  
DN500-600 : 4 bar  
DN700-1200 : 2 bar  
Température de service : -10°C/+80°C  
Manœuvre : Réducteur à volant ou motorisable

Body: Ductile iron EN-GJS-500-7 (GGG50)  
Gate: Stainless steel 304  
Packing:  
DN50-600 = 2 PTFE packing + 1 NBR O-ring  
DN700-800 = 3 PTFE packing + 1 NBR O-ring  
DN900-1200 = 4 PTFE packing + 1 NBR O-ring  
Connection: Between flanges PN10  
Working pressure:  
DN350-450: 7 bar  
DN500-600: 4 bar  
DN700-1200: 2 bar  
Working temperature: -10°C/+80°C  
Operation : Manual gearbox with handwheel or ISO top flange for electric actuator connection



**Ex** ATEX sur demande  
ATEX on request

				Réducteur manuel à volant Manual handwheel gearbox	
DN			Kg	Etanchéité : Nitrile Seat: Nitrile	Etanchéité : Métal/ Métal Seat: Metal/Metal
mm	inch			Ref.	Ref.
250	10"	60	64	VG4400-08NI0250	VG4400-08MM0250
300	12"	70	75	VG4400-08NI0300	VG4400-08MM0300
350	14"	96	127	VG4400-08NI0350	VG4400-08MM0350
400	16"	100	159	VG4400-08NI0400	VG4400-08MM0400
450	18"	110	198	VG4400-08NI0450	VG4400-08MM0450
500	20"	110	233	VG4400-08NI0500	VG4400-08MM0500
600	24"	110	277	VG4400-08NI0600	VG4400-08MM0600

				Réducteur motorisable Motorizable gearbox	
DN			Kg	Etanchéité : Nitrile Seat: Nitrile	Etanchéité : Métal/ Métal Seat: Metal/Metal
mm	inch			Ref.	Ref.
700	28"	110	410	VG4400-08NI0700	VG4400-08MM0700
800	32"	110	560	VG4400-08NI0800	VG4400-08MM0800
900	36"	110	780	VG4400-08NI0900	VG4400-08MM0900
1 000	40"	110	985	VG4400-08NI1000	VG4400-08MM1000
1 200	48"	120	1635	VG4400-08NI1200	VG4400-08MM1200

**Version (ACS) disponible sur demande**  
ACS model available on request



Ductile Iron body

**VG4400-U04NI**

**AUMA**

Vanne à guillotine fonte ductile à tige montante avec moteur AUMA - entre brides PN10  
 Ductile iron rising-stem knife gate valve with AUMA electric actuator - between flanges PN10



Corps : Fonte ductile EN-GJS-500-7 (GGG50)  
 Pelle : Inox 304  
 Joint de siège : NBR  
 Presse Etoupe : DN50-600 = 2 tresses PTFE+ 1 torique NBR  
 DN700-800 = 3 tresses PTFE+ 1 torique NBR  
 DN900-1200 = 4 tresses PTFE+ 1 torique NBR  
 Raccordement : Entre-brides PN10  
 Pression de service :  
 DN50-250 : 10 bar  
 DN300-450 : 7 bar  
 DN500-600 : 4 bar  
 DN700-1200 : 2 bar  
 Température de service : -10°C / +80°C  
 Type de moteur : AUMA 400V 3PH  
 Equipé de capot de protection selon Directive Machine

Body: Ductile Iron EN-GJS-500-7 (GGG50)  
 Gate: Stainless steel 304  
 Seat gasket: NBR  
 Packing: DN50-600 = 2 PTFE packing + 1 NBR O-ring  
 DN700-800 = 3 PTFE packing + 1 NBR O-ring  
 DN900-1200 = 4 PTFE packing + 1 NBR O-ring  
 Connection: Between flanges PN10  
 Working pressure:  
 DN50-250: 10 bar  
 DN300-450: 7 bar  
 DN500-600: 4 bar  
 DN700-1200: 2 bar  
 Working temperature: -10°C/+80°C  
 Actuator type: AUMA 400V 3PH  
 Equipped with protective cover according to Machine Directive



**Ex** ATEX sur demande  
 ATEX on request

Moteur monté sur réducteur motorisable  
 Actuator mounted on gearbox

DN		L (mm)	Kg	Etanchéité : Nitrile Seat: Nitrile
mm	inch			
50	2"	40	27	VG4400-U04NI0050
65	2 1/2"	40	29	VG4400-U04NI0065
80	3"	50	30	VG4400-U04NI0080
100	4"	50	31	VG4400-U04NI0100
125	5"	50	38	VG4400-U04NI0125
150	6"	60	42	VG4400-U04NI0150
200	8"	60	57	VG4400-U04NI0200
250	10"	70	75	VG4400-U04NI0250
300	12"	70	87	VG4400-U04NI0300
350	14"	96	137	VG4400-U04NI0350
400	16"	100	167	VG4400-U04NI0400
450	18"	106	231	VG4400-U04NI0450
500	20"	110	266	VG4400-U04NI0500
600	24"	110	310	VG4400-U04NI0600
700	28"	110	435	VG4400-U04NI0700
800	32"	110	585	VG4400-U04NI0800
900	36"	110	805	VG4400-U04NI0900
1 000	40"	110	1016	VG4400-U04NI1000
1 200	48"	120	1683	VG4400-U04NI1200



Version **ACS** disponible sur demande  
 ACS model available on request



Voir moteur AUMA seul page 119  
 See AUMA actuator on page 119

**VGA4430-U04NI**

**ASA 150 AUMA**

Vanne à guillotine fonte ductile à tige montante avec moteur AUMA - ASA 150  
 Ductile iron rising-stem knife gate valve with AUMA electric actuator - ASA 150



Corps : Fonte ductile EN-GJS-500-7 (GGG50)  
 Pelle : Inox 304  
 Joint de siège : NBR  
 Presse Etoupe : DN50-600 = 2 tresses PTFE+ 1 torique NBR  
 Raccordement : Entre-brides PN10  
 Pression de service :  
 DN50-250 : 10 bar  
 DN300-450 : 7 bar  
 DN500-600 : 4 bar  
 Température de service : -10°C / +80°C  
 Type de moteur : AUMA 400V 3PH  
 Equipé de capot de protection selon Directive Machine

Body: Ductile Iron EN-GJS-500-7 (GGG50)  
 Gate: Stainless steel 304  
 Seat gasket: NBR  
 Packing: DN50-600 = 2 PTFE packing + 1 NBR O-ring  
 Connection: Between flanges PN10  
 Working pressure:  
 DN50-250: 10 bar  
 DN300-450: 7 bar  
 DN500-600: 4 bar  
 Working temperature: -10°C/+80°C  
 Actuator type: AUMA 400V 3PH  
 Equipped with protective cover according to Machine Directive



**Ex** ATEX sur demande  
 ATEX on request

DN		L (mm)	Kg	Etanchéité : Nitrile Seat: Nitrile
mm	inch			
50	2"	40	27	VGA4430-U04NI0050
65	2 1/2"	40	29	VGA4430-U04NI0065
80	3"	50	30	VGA4430-U04NI0080
100	4"	50	31	VGA4430-U04NI0100
125	5"	50	38	VGA4430-U04NI0125
150	6"	60	42	VGA4430-U04NI0150
200	8"	60	57	VGA4430-U04NI0200
250	10"	70	75	VGA4430-U04NI0250
300	12"	70	87	VGA4430-U04NI0300
350	14"	96	137	VGA4430-U04NI0350
400	16"	100	167	VGA4430-U04NI0400
450	18"	106	231	VGA4430-U04NI0450
500	20"	110	266	VGA4430-U04NI0500
600	24"	110	310	VGA4430-U04NI0600



Voir moteur AUMA seul page 119  
 See AUMA actuator on page 119



Cast Iron body

**VG3400-07NI | VG3400-07MM**

**Vérin pneumatique | Pneumatic actuator**

Vanne à guillotine fonte grise à vérin pneumatique simple effet N.F\*  
Cast Iron knife gate valve with single-acting pneumatic actuator N.C\*



**Corps :** Fonte EN-GJL-250 (GG25)  
**Pelle :** Inox 304  
**Presse Etoupe :**  
- 2 tresses PTFE  
- 1 torique NBR  
**Raccordement :** Entre-bridges PN10  
**Pression de service :**  
DN50-150 : 10 bar  
DN200 : 8 bar  
DN250-300 : 6 bar  
**Température de service :** -10°C/+80°C

**Body:** Cast iron EN-GJL-250 (GG25)

**Gate:** Stainless steel 304

**Packing:**

- 2 PTFE packing  
- 1 NBR O-ring

**Connection:** Between flanges PN10

**Working pressure:**

DN50-150: 10 bar

DN200: 8 bar

DN250-300: 6 bar

**Working temperature:** -10°C/+80°C



ATEX sur demande  
ATEX on request



Utiliser de l'air comprimé conforme à la classe de pureté ISO 8573-1  
Use compressed air conforming to the purity class ISO 8573-1

DN		L (mm)	Kg	Etanchéité : Nitrile Seat: Nitrile	Etanchéité : Métal/ Métal Seat: Metal/Metal
mm	inch			Ref.	Ref.
50	2"	40	19	VG3400-07NI0050	VG3400-07MM0050
65	2"1/2	40	22	VG3400-07NI0065	VG3400-07MM0065
80	3"	50	23	VG3400-07NI0080	VG3400-07MM0080
100	4"	50	24	VG3400-07NI0100	VG3400-07MM0100
125	5"	50	35	VG3400-07NI0125	VG3400-07MM0125
150	6"	60	36	VG3400-07NI0150	VG3400-07MM0150
200	8"	60	66	VG3400-07NI0200	VG3400-07MM0200
250	10"	70	130	VG3400-07NI0250	VG3400-07MM0250
300	12"	70	143	VG3400-07NI0300	VG3400-07MM0300

\*N.O sur demande / N.O on request



**Au delà du DN300, prévoir VG double effet avec ballon réserve de secours d'air comprimé.**  
**Beyond DN300, provide double-acting KGV with emergency compressed air tank.**





**VANNE A GUILLOTINE - INOX**  
**KNIFE GATE VALVE - STAINLESS STEEL**



Stainless steel body

VG6400-00EP | VG6400-00MM | VG6400-00EA

Tige montante | Rising-stem

Vanne à guillotine à volant tige montante  
Rising-stem cast iron knife gate valve with handwheel



Corps : Inox 316 (CF8M)  
Pelle : Inox 316L  
Presse Etoupe : 2 tresses PTFE + 1 torique EPDM  
Raccordement : Entre-bridés PN10  
Pression de service :  
DN50-250 : 10 bar  
DN300-450 : 7 bar  
DN500-600 : 4 bar  
Température de service : -10°/+130°C

Body: Stainless steel 316 (CF8M)  
Gate: Stainless steel 316L  
Packing: 2 PTFE packing + 1 EPDM O-ring  
Connection: Between flanges PN10  
Working pressure:  
DN50-250: 10 bar  
DN300-450: 7 bar  
DN500-600: 4 bar  
Maximum working temperature:  
-10°/+130°C



ATEX sur demande  
ATEX on request

Réducteur conseillé  
> DN400  
Gearbox is  
recommended  
> DN400

DN		L (mm)	Kg	Etanchéité : EPDM Seat: EPDM	Etanchéité : Métal/ Métal Seat: Metal/Metal
mm	inch			Ref.	Ref.
50	2"	40	7,5	VG6400-00EP0050	VG6400-00MM0050
65	2 1/2"	40	9	VG6400-00EP0065	VG6400-00MM0065
80	3"	50	10	VG6400-00EP0080	VG6400-00MM0080
100	4"	50	11,5	VG6400-00EP0100	VG6400-00MM0100
125	5"	50	15,5	VG6400-00EP0125	VG6400-00MM0125
150	6"	60	18,5	VG6400-00EP0150	VG6400-00MM0150
200	8"	60	35	VG6400-00EP0200	VG6400-00MM0200
250	10"	70	47	VG6400-00EP0250	VG6400-00MM0250
300	12"	70	61	VG6400-00EP0300	VG6400-00MM0300
350	14"	96	117	VG6400-00EP0350	VG6400-00MM0350
400	16"	100	151	VG6400-00EP0400	VG6400-00MM0400
450	18"	106	187	VG6400-00EP0450	VG6400-00MM0450
500	20"	110	205	VG6400-00EP0500	VG6400-00MM0500
600	24"	110	292	VG6400-00EP0600	VG6400-00MM0600



Plaques supports Inox 304 et 316 page 126 pour une vanne tout inox !  
Support plates SS 304 and 316 on page 126 for a Stainless steel valve!



Optez pour la version ACS, pour vos applications sur eau potable !

Order ACS version for your drinking water applications!

**ACS**



Corps : Inox 316 (CF8M)  
Pelle : Inox 316L  
Joint : EPDM ACS  
Tresse : PTFE compatible eau potable  
Raccordement : Entre-bridés PN10  
Pression de service :  
DN50-250 : 10 bar  
DN300-450 : 7 bar  
DN500-600 : 4 bar  
Température de service : -10°C/+ 80°C

Body: Stainless steel 316 (CF8M)  
Gate: Stainless steel 316L  
Seal: EPDM ACS  
Packing: PTFE suitable for potable water  
Connection: Between flanges PN10  
Working pressure:  
DN50-250: 10 bar  
DN300-450: 7 bar  
DN500-600: 4 bar  
Working temperature: -10°C/+ 80°C



DN		L (mm)	Kg	EPDM ACS
mm	inch			Ref.
50	2"	40	7,5	VG6400-00EA0050
65	2 1/2"	40	9	VG6400-00EA0065
80	3"	50	10	VG6400-00EA0080
100	4"	50	11,5	VG6400-00EA0100
125	5"	50	15,5	VG6400-00EA0125
150	6"	60	18,5	VG6400-00EA0150
200	8"	60	35	VG6400-00EA0200
250	10"	70	47	VG6400-00EA0250
300	12"	70	61	VG6400-00EA0300
350	14"	96	117	VG6400-00EA0350
400	16"	100	151	VG6400-00EA0400
450	18"	106	187	VG6400-00EA0450
500	20"	110	205	VG6400-00EA0500
600	24"	110	292	VG6400-00EA0600

corps inox



Stainless steel body

## VGA6430-00EP | VGA6430-00MM

## ASA 150 Tige montante | Rising-stem

Vanne à guillotine à volant tige montante - ASA 150  
Rising-stem knife gate valve with handwheel - ASA 150



Corps : Inox 316 (CF8M)  
Pelle : Inox 316L  
Presse Etoupe : 2 tresses PTFE + 1 torique EPDM  
Raccordement : ASA 150  
Pression de service :  
DN50-250 : 10 bar  
DN300-450 : 7 bar  
DN500-600 : 4 bar  
Température de service : -10°/130°C

Body: Stainless steel 316 (CF8M)  
Gate: Stainless steel 316L  
Packing: 2 PTFE packing + 1 EPDM O-ring  
Connection: ASA 150  
Working pressure:  
DN50-250: 10 bar  
DN300-450: 7 bar  
DN500-600: 4 bar  
Working temperature:  
-10°/130°C

Réducteur conseillé  
> DN400  
Gearbox is  
recommended  
> DN400

DN		L (mm)	Kg	Etanchéité : EPDM Seat: EPDM	Etanchéité : Métal/ Métal Seat: Metal/Metal
mm	inch			Ref.	Ref.
50	2"	40	7,5	VGA6430-00EP0050	VGA6430-00MM0050
65	2 1/2"	40	9	VGA6430-00EP0065	VGA6430-00MM0065
80	3"	50	10	VGA6430-00EP0080	VGA6430-00MM0080
100	4"	50	11,5	VGA6430-00EP0100	VGA6430-00MM0100
125	5"	50	15,5	VGA6430-00EP0125	VGA6430-00MM0125
150	6"	60	18,5	VGA6430-00EP0150	VGA6430-00MM0150
200	8"	60	35	VGA6430-00EP0200	VGA6430-00MM0200
250	10"	70	47	VGA6430-00EP0250	VGA6430-00MM0250
300	12"	70	61	VGA6430-00EP0300	VGA6430-00MM0300
350	14"	96	117	VGA6430-00EP0350	VGA6430-00MM0350
400	16"	100	151	VGA6430-00EP0400	VGA6430-00MM0400
450	18"	106	187	VGA6430-00EP0450	VGA6430-00MM0450
500	20"	110	205	VGA6430-00EP0500	VGA6430-00MM0500
600	24"	110	292	VGA6400-00EP0600	VGA6400-00MM0600

Autre type de siège sur demande  
Other seat type on request



Plaques supports Inox 304 et 316 page 126 pour une vanne tout inox !  
Support plates SS 304 and 316 on page 126 for a Stainless steel valves!



Voir kit cadenassable page 117  
See locking kit on page 117





Stainless steel body

VG6400-001EP | VG6400-001MM | VG6400-001EA

Tige non montante | Non-rising stem

Vanne à guillotine à volant tige non montante  
Non-rising stem knife gate valve with handwheel



ATEX sur demande  
ATEX on request



**Encombrement optimisé en hauteur**  
Optimized height



Corps : Inox 316 (CF8M)  
Pelle : Inox 316L  
Presse Etoupe : 2 tresses PTFE + 1 torique EPDM  
Raccordement : Entre-brides PN10  
Pression de service :  
DN50-250 : 10 bar  
DN300-450 : 7 bar  
DN500-600 : 4 bar  
Température de service : -10°/130°C

Body: Stainless steel 316 (CF8M)  
Gate: Stainless steel 316L  
Packing: 2 PTFE packing + 1 EPDM O-ring  
Connection: Between flanges PN10  
Working pressure:  
DN50-250: 10 bar  
DN300-450: 7 bar  
DN500-600: 4 bar  
Working temperature: -10°/130°C

Etanchéité : EPDM Seat: EPDM		Etanchéité : Métal/ Métal Seat: Metal/Metal	
---------------------------------	--	---	--

DN		L (mm)	Kg	Ref.	Ref.
mm	inch				
50	2"	40	7,5	VG6400-001EP0050	VG6400-001MM0050
65	2"1/2	40	8,8	VG6400-001EP0065	VG6400-001MM0065
80	3"	50	9,4	VG6400-001EP0080	VG6400-001MM0080
100	4"	50	11,5	VG6400-001EP0100	VG6400-001MM0100
125	5"	50	15,4	VG6400-001EP0125	VG6400-001MM0125
150	6"	60	18,5	VG6400-001EP0150	VG6400-001MM0150
200	8"	60	34,8	VG6400-001EP0200	VG6400-001MM0200
250	10"	70	47	VG6400-001EP0250	VG6400-001MM0250
300	12"	70	61	VG6400-001EP0300	VG6400-001MM0300
350	14"	96	117	VG6400-001EP0350	VG6400-001MM0350
400	16"	100	151	VG6400-001EP0400	VG6400-001MM0400
450	18"	106	187	VG6400-001EP0450	VG6400-001MM0450
500	20"	110	205	VG6400-001EP0500	VG6400-001MM0500
600	24"	110	292	VG6400-001EP0600	VG6400-001MM0600



Optez pour la version ACS, pour vos applications sur eau potable !

Order ACS version for your drinking water applications!

**ACS**



Corps : Inox 316 (CF8M)  
Pelle : Inox 316L  
Joint : EPDM ACS  
Tresse : PTFE compatible eau potable  
Raccordement : Entre-brides PN10  
Pression de service :  
DN50-250 : 10 bar  
DN300-450 : 7 bar  
DN500-600 : 4 bar  
Température de service : -10°C/+ 80°C

Body: Stainless steel 316 (CF8M)  
Gate: Stainless steel 316L  
Seal: EPDM ACS  
Packing: PTFE suitable potable water  
Connection: Between flanges PN10  
Working pressure:  
DN50-250: 10 bar  
DN300-450: 7 bar  
DN500-600: 4 bar  
Working temperature: -10°C/+ 80°C

EPDMACS

DN		L (mm)	Kg	Ref.
mm	inch			
50	2"	40	7,5	VG6400-001EA0050
65	2"1/2	40	8,8	VG6400-001EA0065
80	3"	50	9,4	VG6400-001EA0080
100	4"	50	11,5	VG6400-001EA0100
125	5"	50	15,4	VG6400-001EA0125
150	6"	60	18,5	VG6400-001EA0150
200	8"	60	34,8	VG6400-001EA0200
250	10"	70	47	VG6400-001EA0250
300	12"	70	61	VG6400-001EA0300
350	14"	96	117	VG6400-001EA0350
400	16"	100	151	VG6400-001EA0400
450	18"	106	187	VG6400-001EA0450
500	20"	110	205	VG6400-001EA0500
600	24"	110	292	VG6400-001EA0600





corps inox



Stainless steel body

**VG6400-051EP | VG6400-051MM**

**Commande par carré de manoeuvre | Square operating**

Vanne à guillotine à tige non montante et à carré de manoeuvre  
Non-rising stem knife gate valve with square operating

Etanchéité : EPDM  
Seat: EPDM

Etanchéité : Métal/  
Métal  
Seat: Metal/Metal

DN		L (mm)	Kg	Ref.	Ref.
mm	inch				
50	2"	40	6	VG6400-051EP0050	VG6400-051MM0050
65	2 1/2"	40	7,8	VG6400-051EP0065	VG6400-051MM0065
80	3"	50	8,4	VG6400-051EP0080	VG6400-051MM0080
100	4"	50	10,5	VG6400-051EP0100	VG6400-051MM0100
125	5"	50	14,4	VG6400-051EP0125	VG6400-051MM0125
150	6"	60	17,5	VG6400-051EP0150	VG6400-051MM0150
200	8"	60	32,8	VG6400-051EP0200	VG6400-051MM0200
250	10"	70	45	VG6400-051EP0250	VG6400-051MM0250
300	12"	70	59	VG6400-051EP0300	VG6400-051MM0300
350	14"	96	114	VG6400-051EP0350	VG6400-051MM0350
400	16"	100	148	VG6400-051EP0400	VG6400-051MM0400
450*	18"	106	186	VG6400-051EP0450	VG6400-051MM0450

\*Manœuvre manuelle non recommandée à partir du DN450  
Manual operation not recommended from DN450



Corps : Inox 316 (CF8M)  
Pelle : Inox 316L  
Presse Etope :  
- 2 tresses PTFE  
- 1 torique EPDM  
Raccordement : Entre-brides PN10  
Pression de service :  
DN50-250 : 10 bar  
DN300-400 : 7 bar  
DN500 : 4 bar  
Température de service : -10°C/+130°C

Body: Stainless steel 316 (CF8M)  
Gate: Stainless steel 316L

Packing:  
- 2 PTFE packing  
- 1 EPDM O-ring  
Connection: Between flanges PN10

Working pressure:  
DN50-250: 10 bar  
DN300-400: 7 bar  
DN500: 4 bar  
Working temperature: -10°C+130°C



ATEX sur demande  
ATEX on request



**Vanne idéale pour montage avec colonnette droite et murale ou installée dans un regard. Voir pages 136-137**  
Valve adapted for pedestal floor and wall mounted. See on pages 136-137



**Voir carré seul page 116**  
See ref square on page 116



**VG6400-02EP | VG6400-02MM**

**Commande par levier | Lever operating**

Vanne à guillotine à levier  
Knife gate valve lever operating



**Pour ouverture et fermeture rapide**  
For quick opening and closing



Corps : Inox 316 (CF8M)  
Pelle : Inox 316L  
Presse Etope :  
- 2 tresses PTFE  
- 1 torique EPDM  
Raccordement : Entre-brides PN10  
Pression de service :  
DN50-250 : 10 bar  
DN300 : 7 bar  
Température de service : -10°/130°C  
Actionnement de manoeuvre rapide par levier

Body: Stainless steel 316 (CF8M)  
Gate: Stainless steel 316L

Packing:  
- 2 PTFE packing  
- 1 EPDM O-ring  
Connection: Between flanges PN10

Working pressure:  
DN50-250: 10 bar  
DN300: 7 bar  
Maximum Working temperature: -10°/130°C  
Fast lever actuation



ATEX sur demande  
ATEX on request



Etanchéité : EPDM  
Seat: EPDM

Etanchéité : Métal/  
Métal  
Seat: Metal/Metal

DN		L (mm)	Kg	Ref.	Ref.
mm	inch				
50	2"	40	7,5	VG6400-02EP0050	VG6400-02MM0050
65	2 1/2"	40	7,8	VG6400-02EP0065	VG6400-02MM0065
80	3"	50	8,4	VG6400-02EP0080	VG6400-02MM0080
100	4"	50	11,5	VG6400-02EP0100	VG6400-02MM0100
125	5"	50	14,4	VG6400-02EP0125	VG6400-02MM0125
150	6"	60	18,5	VG6400-02EP0150	VG6400-02MM0150
200	8"	60	28,8	VG6400-02EP0200	VG6400-02MM0200
250*	10"	70	41	VG6400-02EP0250	VG6400-02MM0250
300*	12"	70	58	VG6400-02EP0300	VG6400-02MM0300

\*Attention, manoeuvre plus difficile à partir du DN250  
Please note: more difficult to operate from DN250 and up



**Version (ACS) disponible sur demande**  
ACS model available on request



**Voir kit cadennassable page 117**  
See locking kit on page 117



corps inox



Stainless steel body

VG6400-03EP | VG6400-03MM | VG6400-03EA

Vérin pneumatique | Pneumatic actuator

Vanne à guillotine à vérin pneumatique double effet  
Knife gate valve with double-acting pneumatic actuator



Corps : Inox 316 (CF8M)  
Pelle : Inox 316L  
Presse Etoupe :  
DN50-600 = 2 tresses PTFE+ 1 torique EPDM  
DN700-800 = 3 tresses PTFE+ 1 torique EPDM  
DN900-1200 = 4 tresses PTFE+ 1 torique EPDM  
Raccordement : Entre-brides PN10  
Pression de service :  
DN50-250 : 10 bar  
DN300-450 : 7 bar  
DN500-600 : 4 bar  
DN700-1200 : 2 bar  
Température de service : -10°/130°C  
Capot de protection : Inox 304  
Vérin pneumatique double effet 6 bar

Body: Stainless steel 316 (CF8M)  
Gate: Stainless steel 316L  
Packing: DN50-600 = 2 PTFE packing + 1 EPDM O-ring  
DN700-800 = 3 PTFE packing + 1 EPDM O-ring  
DN900-1200 = 4 PTFE packing + 1 EPDM O-ring  
Connection: Between flanges PN10  
Working pressure:  
DN50-250: 10 bar  
DN300-450: 7 bar  
DN500-600: 4 bar  
DN700-1200: 2 bar  
Maximum Working temperature: -10°/130°C  
Protective cover: Stainless steel 304  
Double-acting pneumatic actuator 6 bar



ATEX sur demande  
ATEX on request

DN		L (mm)	Kg	Etanchéité : EPDM Seat: EPDM	Etanchéité : Métal/ Métal Seat: Metal/Metal
mm	inch			Ref.	Ref.
50	2"	40	7,5	VG6400-03EP0050	VG6400-03MM0050
65	2 1/2"	40	7,8	VG6400-03EP0065	VG6400-03MM0065
80	3"	50	8,4	VG6400-03EP0080	VG6400-03MM0080
100	4"	50	12,5	VG6400-03EP0100	VG6400-03MM0100
125	5"	50	16,4	VG6400-03EP0125	VG6400-03MM0125
150	6"	60	20,5	VG6400-03EP0150	VG6400-03MM0150
200	8"	60	35,8	VG6400-03EP0200	VG6400-03MM0200
250	10"	70	52	VG6400-03EP0250	VG6400-03MM0250
300	12"	70	72	VG6400-03EP0300	VG6400-03MM0300
350	14"	96	129	VG6400-03EP0350	VG6400-03MM0350
400	16"	100	144	VG6400-03EP0400	VG6400-03MM0400
450	18"	106	177	VG6400-03EP0450	VG6400-03MM0450
500	20"	110	268	VG6400-03EP0500	VG6400-03MM0500
600	24"	110	351	VG6400-03EP0600	VG6400-03MM0600
700	28"	110	556	VG6400-03EP0700	VG6400-03MM0700
800	32"	110	679	VG6400-03EP0800	VG6400-03MM0800
900	36"	110	840	VG6400-03EP0900	VG6400-03MM0900
1 000	40"	110	1053	VG6400-03EP1000	VG6400-03MM1000
1 200	48"	120	-	VG6400-03EP1200	VG6400-03MM1200

Version avec vérin pneumatique simple effet voir page 102  
Version equipped with single-acting pneumatic actuator, see page 102



Optez pour la version ACS, pour vos applications sur eau potable!

Order ACS version for your drinking water applications!

**ACS**



Joint : EPDM ACS  
Tresse : PTFE compatible eau potable  
Température de service : -10°C/+ 80°C  
Seal: EPDM ACS  
Packing: PTFE suitable potable water  
Working temperature: -10°C/+80°C



DN		L (mm)	Kg	EPDM ACS	
mm	inch			Ref.	Ref.
50	2"	40	7,5	VG6400-03EA0050	
65	2 1/2"	40	7,8	VG6400-03EA0065	
80	3"	50	8,4	VG6400-03EA0080	
100	4"	50	12,5	VG6400-03EA0100	
125	5"	50	16,4	VG6400-03EA0125	
150	6"	60	20,5	VG6400-03EA0150	
200	8"	60	35,8	VG6400-03EA0200	
250	10"	70	52	VG6400-03EA0250	
300	12"	70	72	VG6400-03EA0300	
350	14"	96	129	VG6400-03EA0350	
400	16"	100	144	VG6400-03EA0400	
450	18"	106	177	VG6400-03EA0450	
500	20"	110	268	VG6400-03EA0500	
600	24"	110	351	VG6400-03EA0600	

corps inox



Stainless steel body

VGA6430-03EP | VGA6430-03MM

ASA150 Vérin pneumatique | Pneumatic actuator

Vanne à guillotine à vérin pneumatique double effet - ASA 150

Knife gate valve with double-acting pneumatic actuator ASA 150



Corps : Inox 316 (CF8M)  
 Pelle : Inox 316L  
 Presse Etoupe : 2 tresses PTFE + 1 torique EPDM  
 Raccordement : ASA 150  
 Pression de service :  
 DN50-250 : 10 bar  
 DN300-450 : 7 bar  
 DN500-600 : 4 bar  
 Température de service : -10°/130°C

Body: Stainless steel 316 (CF8M)  
 Gate: Stainless Steel 316L  
 Packing: 2 PTFE packing + 1 EPDM O-ring  
 Connection: ASA 150  
 Working pressure:  
 DN50-250: 10 bar  
 DN300-450: 7 bar  
 DN500-600: 4 bar  
 Maximum Working temperature: -10°/130°C

DN		L (mm)	Kg	Etanchéité : EPDM Seat: EPDM	Etanchéité : Métal/ Métal Seat: Metal/Metal
mm	inch			Ref.	Ref.
50	2"	40	7,5	VGA6430-03EP0050	VGA6430-03MM0050
65	2"1/2	40	7,8	VGA6430-03EP0065	VGA6430-03MM0065
80	3"	50	8,4	VGA6430-03EP0080	VGA6430-03MM0080
100	4"	50	12,5	VGA6430-03EP0100	VGA6430-03MM0100
125	5"	50	16,4	VGA6430-03EP0125	VGA6430-03MM0125
150	6"	60	20,5	VGA6430-03EP0150	VGA6430-03MM0150
200	8"	60	35,8	VGA6430-03EP0200	VGA6430-03MM0200
250	10"	70	52	VGA6430-03EP0250	VGA6430-03MM0250
300	12"	70	72	VGA6430-03EP0300	VGA6430-03MM0300
350	14"	96	129	VGA6430-03EP0350	VGA6430-03MM0350
400	16"	100	144	VGA6430-03EP0400	VGA6430-03MM0400
450	18"	106	177	VGA6430-03EP0450	VGA6430-03MM0450
500	20"	110	268	VGA6430-03EP0500	VGA6430-03MM0500
600	24"	110	351	VGA6400-03EP0600	VGA6400-03MM0600



Utiliser de l'air comprimé conforme à la classe de pureté ISO 8573-1  
 Use compressed air conforming to the purity class ISO 8573-1

Autre DN sur demande / Other DN on request

VG6400-07EP | VG6400-07MM

Vérin pneumatique | Pneumatic actuator

Vanne à guillotine à vérin pneumatique simple effet N.F

Knife gate valve with single-acting pneumatic actuator N.C\*



Corps : Inox 316 (CF8M)  
 Pelle : Inox 316L  
 Presse Etoupe : 2 tresses PTFE + 1 torique EPDM  
 Raccordement : Entre-brides PN10  
 Pression de service :  
 DN50-150 : 10 bar  
 DN200 : 8 bar  
 DN250-300 : 6 bar  
 Température de service : -10°/130°C

Body: Stainless steel 316 (CF8M)  
 Gate: Stainless steel 316L  
 Packing: 2 PTFE packing + 1 EPDM O-ring  
 Connection: Between flanges PN10  
 Working pressure:  
 DN50-150: 10 bar  
 DN200: 8 bar  
 DN250-300: 6 bar  
 Working temperature: -10°/130°C

DN		L (mm)	Kg	Etanchéité : EPDM Seat: EPDM	Etanchéité : Métal/ Métal Seat: Metal/Metal
mm	inch			Ref.	Ref.
50	2"	40	19	VG6400-07EP0050	VG6400-07MM0050
65	2"1/2	40	22	VG6400-07EP0065	VG6400-07MM0065
80	3"	50	23	VG6400-07EP0080	VG6400-07MM0080
100	4"	50	24	VG6400-07EP0100	VG6400-07MM0100
125	5"	50	35	VG6400-07EP0125	VG6400-07MM0125
150	6"	60	36	VG6400-07EP0150	VG6400-07MM0150
200	8"	60	66	VG6400-07EP0200	VG6400-07MM0200
250	10"	70	130	VG6400-07EP0250	VG6400-07MM0250
300	12"	70	143	VG6400-07EP0300	VG6400-07MM0300

\*N.O sur demande / N.O on request



ATEX sur demande  
 ATEX on request



Utiliser de l'air comprimé conforme à la classe de pureté ISO 8573-1  
 Use compressed air conforming to the purity class ISO 8573-1



**Au delà du DN300, prévoir VG double effet avec ballon réserve de secours d'air comprimé.**  
**From DN300, plan for a double-acting VG with emergency reserve of compressed air.**



Stainless steel body

VG6400-004EP | VG6400-004MM

Embase ISO | ISO mounting plate

Vanne à guillotine tige montante avec embase ISO pour motorisation électrique  
Rising-stem knife gate valve with ISO mounting plate for electric actuator



Corps : Inox 316 (CF8M)  
Pelle : Inox 316L  
Presse Etoupe : 2 tresses PTFE + 1 torique EPDM  
Raccordement : Entre-brides PN10  
Pression de service :  
DN50-250 : 10 bar  
DN300-450 : 7 bar  
DN500-600 : 4 bar  
Température de service : -10°/130°C

Body: Stainless steel 316 (CF8M)  
Gate: Stainless steel 316L  
Packing: 2 PTFE packing + 1 EPDM O-ring  
Connection: Between flanges PN10  
Working pressure:  
DN50-250: 10 bar  
DN300-450: 7 bar  
DN500-600: 4 bar  
Maximum Working temperature: -10°/130°C



**Ex** ATEX sur demande  
ATEX on request

**Version (ACS) disponible sur demande**  
ACS model available on request

**Avec embase de motorisation et tige de manœuvre rallongée pour accouplement**  
With ISO mounting plate and extended operating rod for coupling

DN		L (mm)	Kg	Etanchéité : EPDM Seat: EPDM	Etanchéité : Métal/ Métal Seat: Metal/Metal
mm	inch			Ref.	Ref.
50	2"	40	6	VG6400-004EP0050	VG6400-004MM0050
65	2 1/2"	40	8	VG6400-004EP0065	VG6400-004MM0065
80	3"	50	9	VG6400-004EP0080	VG6400-004MM0080
100	4"	50	10	VG6400-004EP0100	VG6400-004MM0100
125	5"	50	15	VG6400-004EP0125	VG6400-004MM0125
150	6"	60	19	VG6400-004EP0150	VG6400-004MM0150
200	8"	60	33	VG6400-004EP0200	VG6400-004MM0200
250	10"	70	47	VG6400-004EP0250	VG6400-004MM0250
300	12"	70	58	VG6400-004EP0300	VG6400-004MM0300
350	14"	96	107	VG6400-004EP0350	VG6400-004MM0350
400	16"	100	137	VG6400-004EP0400	VG6400-004MM0400
450	18"	106	177	VG6400-004EP0450	VG6400-004MM0450
500	20"	110	212	VG6400-004EP0500	VG6400-004MM0500
600	24"	110	256	VG6400-004EP0600	VG6400-004MM0600

Pour DN supérieur, voir vannes avec réducteur motorisable  
Other DN, please check the valve stem gearbox actuator operating

VG6400-08EP | VG6400-08MM

Réducteur manuel | Gearbox actuator

Vanne à guillotine à réducteur manuel  
Knife gate valve with gearbox



Corps : Inox 316 (CF8M)  
Pelle : Inox 316L  
Presse Etoupe :  
DN50-600 = 2 PTFE packing + 1 EPDM O-ring  
DN700-800 = 3 PTFE packing + 1 EPDM O-ring  
DN900-1200 = 4 PTFE packing + 1 EPDM O-ring  
Raccordement : Entre-brides PN10  
Pression de service :  
DN350-450 : 7 bar  
DN500-600 : 4 bar  
DN700-1200 : 2 bar  
Température de service : -10°/130°C  
Manœuvre : Réducteur à volant ou motorisable

Body: Stainless steel 316 (CF8M)  
Gate: Stainless steel 316L  
Packing:  
DN50-600 = 2 PTFE packing + 1 EPDM O-ring  
DN700-800 = 3 PTFE packing + 1 EPDM O-ring  
DN900-1200 = 4 PTFE packing + 1 EPDM O-ring  
Connection: Between flanges PN10  
Working pressure:  
DN350-450: 7 bar  
DN500-600: 4 bar  
DN700-1200: 2 bar  
Working temperature: -10°/130°C  
Operation: Manual gearbox with handwheel or ISO top flange for electric actuator connection



**Ex** ATEX sur demande  
ATEX on request

**Version (ACS) disponible sur demande**  
ACS model available on request

DN		L (mm)	Kg	Réducteur manuel à volant Manual gearbox	
mm	inch			Etanchéité : EPDM Seat: EPDM	Etanchéité : Métal/ Métal Seat: Metal/Metal
250	10"	70	64	VG6400-08EP0250	VG6400-08MM0250
300	12"	70	75	VG6400-08EP0300	VG6400-08MM0300
350	14"	96	127	VG6400-08EP0350	VG6400-08MM0350
400	16"	100	159	VG6400-08EP0400	VG6400-08MM0400
450	18"	106	198	VG6400-08EP0450	VG6400-08MM0450
500	20"	110	233	VG6400-08EP0500	VG6400-08MM0500
600	24"	110	277	VG6400-08EP0600	VG6400-08MM0600

DN		L (mm)	Kg	Réducteur motorisable Motorizable gearbox with ISO top flange	
mm	inch			Etanchéité : EPDM Seat: EPDM	Etanchéité : Métal/ Métal Seat: Metal/Metal
700	28"	110	612	VG6400-08EP0700	VG6400-08MM0700
800	32"	110	657	VG6400-08EP0800	VG6400-08MM0800
900	36"	110	917	VG6400-08EP0900	VG6400-08MM0900
1 000	40"	110	1 260	VG6400-08EP1000	VG6400-08MM1000
1 200	48"	120	-	VG6400-08EP1200	VG6400-08MM1200



Stainless steel body

VG6400-U04EP | VGA6430-U04

AUMA

Vanne à guillotine avec moteur AUMA - entre brides PN10 / ASA 150  
Knife gate valve with AUMA electric actuator - between flanges PN10



Corps : Inox 316 (CF8M)  
Pelle : Inox 316L  
Presse Etoupe :  
DN50-600 = 2 tresses PTFE+ 1 torique EPDM  
DN700-800 = 3 tresses PTFE+ 1 torique EPDM  
DN900-1200 = 4 tresses PTFE+ 1 torique EPDM  
Raccordement : Entre-brides PN10 / ASA 150  
Pression de service :  
DN350-450 : 7 bar  
DN500-600 : 4 bar  
DN700-1200 : 2 bar  
Température de service : -10°/130°C  
Type de moteur : AUMA 400V 3PH  
Equipé de capot de protection selon Directive Machine

Body: Stainless steel 316 (CF8M)  
Gate: Stainless steel 316L  
Packing:  
DN50-600 = 2 PTFE packing + 1 EPDM O-ring  
DN700-800 = 3 PTFE packing + 1 EPDM O-ring  
DN900-1200 = 4 PTFE packing + 1 EPDM O-ring  
Connection: Between flanges PN10 / ASA 150  
Working pressure:  
DN350-450: 7 bar  
DN500-600: 4 bar  
DN700-1200: 2 bar  
Working temperature: -10°/130°C  
Actuator type: AUMA 400V 3PH  
Equipped with protective cover according to Machine Directive

Moteur monté sur réducteur motorisable  
Actuator mounted on gearbox



ATEX sur demande  
ATEX on request

DN		L (mm)	Kg	PN10	ASA150
mm	inch			Ref.	Ref.
50	2"	40	27	VG6400-U04EP0050	VGA6430-U04EP0050
65	2 1/2"	40	29	VG6400-U04EP0065	VGA6430-U04EP0065
80	3"	50	30	VG6400-U04EP0080	VGA6430-U04EP0080
100	4"	50	31	VG6400-U04EP0100	VGA6430-U04EP0100
125	5"	50	38	VG6400-U04EP0125	VGA6430-U04EP0125
150	6"	60	42	VG6400-U04EP0150	VGA6430-U04EP0150
200	8"	60	57	VG6400-U04EP0200	VGA6430-U04EP0200
250	10"	70	75	VG6400-U04EP0250	VGA6430-U04EP0250
300	12"	70	87	VG6400-U04EP0300	VGA6430-U04EP0300
350	14"	96	137	VG6400-U04EP0350	VGA6430-U04EP0350
400	16"	100	167	VG6400-U04EP0400	VGA6430-U04EP0400
450	18"	106	231	VG6400-U04EP0450	VGA6430-U04EP0450
500	20"	110	266	VG6400-U04EP0500	VGA6430-U04EP0500
600	24"	110	310	VG6400-U04EP0600	VGA6430-U04EP0600
700	28"	110	556	VG6400-U04EP0700	-
800	32"	110	679	VG6400-U04EP0800	-
900	36"	110	840	VG6400-U04EP0900	-
1 000	40"	110	1053	VG6400-U04EP1000	-
1 200	48"	120	-	VG6400-U04EP1200	-

Autre type d'étanchéité (NI / MM) sur demande  
Other seat types available (NI/MM) on request



Version (ACS) disponible sur demande  
ACS model available on request



Voir moteur AUMA seul page 119  
See AUMA actuators on page 119

VG6400-031

Commande de secours | Manual emergency control

Vanne à guillotine à vérin pneumatique double effet + commande manuelle de secours  
Knife gate valve with double-acting pneumatic actuator + manual emergency control



Corps : Inox 316  
Pelle : Inox 316  
Siège : EPDM  
Presse Etoupe : 2 tresses PTFE + 1 torique EPDM  
Raccordement : Entre-brides PN10  
Pression de service :  
DN50-250 : 10 bar  
DN300-450 : 7 bar  
DN500-600 : 4 bar  
Température de service : -10°C/+130°C  
Capot de protection : Inox 304  
Vérin pneumatique double effet 6 bar équipé de commande manuelle de secours

Body: Stainless steel 316  
Gate: Stainless steel 316  
Seat: EPDM  
Packing: 2 PTFE packing + 1 EPDM O-ring  
Connection: Between flanges PN10  
Working pressure:  
DN50-250: 10 bar  
DN300-450: 7 bar  
DN500-600: 4 bar  
Working temperature: -10°C/+130°C  
Protective cover: Stainless steel 304  
Double-acting pneumatic actuator 6 bar equipped with manual emergency control

DN		L (mm)	Kg	Ref.
mm	inch			
50	2"	40	10	VG6400-031EP0050
65	2 1/2"	40	11	VG6400-031EP0065
80	3"	50	12	VG6400-031EP0080
100	4"	50	15	VG6400-031EP0100
125	5"	50	21	VG6400-031EP0125
150	6"	60	27	VG6400-031EP0150
200	8"	60	45	VG6400-031EP0200
250	10"	70	69	VG6400-031EP0250
300	12"	70	89	VG6400-031EP0300
350	14"	96	153	VG6400-031EP0350
400	16"	100	166	VG6400-031EP0400
450	18"	106	212	VG6400-031EP0450
500	20"	110	251	VG6400-031EP0500
600	24"	110	300	VG6400-031EP0600



ATEX sur demande  
ATEX on request



Voir kit de commande seul page 119  
See control kit on page 119



Utiliser de l'air comprimé conforme à la classe de pureté ISO 8573-1  
Use compressed air conforming to the purity class ISO 8573-1



# VG BIDIRECTIONNELLE

## BIDIRECTIONAL KNIFE GATE VALVE



### Etanchéité Bi-directionnelle

Cette vanne de construction monobloc est étanche dans les deux sens. Elle est principalement utilisée pour des liquides faiblement chargés comme les réseaux d'adduction d'eau.

### ✓ Bi-directional sealing

This one-piece body knife gate valve is watertight in both directions. This model is mainly used for slightly contaminated fluids like for water networks.



### VANNE À GUILLOTINE BIDIRECTIONNELLE ENCOMBREMENT CONFORME À LA NORME EN558 SÉRIE 20

DN 50 à 400 - PN10

### *Bidirectional knife gate valves Face to face according EN558 serie 20*

DN 50 up to 400 - PN10

### CORPS FONTE DUCTILE

*Ductile Iron body*

**Pour une utilisation optimale, utilisez la pelle polie miroir. Elle permet de diminuer l'accroche des produits en position fermée. (Option de traitement de pelle sur demande, voir page 135)**

For optimal use, use a mirror-polished gate.

It reduces the grip of products in the closed position. (Treated gate option on request, see on page 135)

### VGB3400N-001NI | VGB4400-001NI

### Volant et tige non montante | Non-rising stem with handwheel

Vanne à guillotine bidirectionnelle à tige non montante à volant  
Non-rising stem **bidirectional** type knife gate valve with handwheel



Corps : Voir tableau

Pelle : Inox 304

Siège : NBR

Presse Étoupe :

- 2 tresses PTFE

- 1 torique NBR

Raccordement :

Entre-brides PN10

Pression de service :

DN50-250 : 10 bar

DN300-400 : 7 bar

Température de service :

-10°C/+80°C

Body: See on the table

Gate: Stainless steel 304

Seat: NBR

Packing:

- 2 PTFE packing

- 1 NBR O-ring

Connection:

Between flanges PN10

Working pressure:

DN50-250: 10 bar

DN300-400: 7 bar

Working temperature:

-10°C/+80°C

				Fonte ductile Ductile Iron (GGG50)	
DN		L (mm)	Kg	Ref.	
mm	inch				
50	2"	43	9	VGB4400-001NI0050	
65	2 1/2"	46	10	VGB4400-001NI0065	
80	3"	46	11	VGB4400-001NI0080	
100	4"	52	14	VGB4400-001NI0100	
125	5"	56	18	VGB4400-001NI0125	
150	6"	56	21	VGB4400-001NI0150	
200	8"	60	34	VGB4400-001NI0200	
250	10"	68	51	VGB4400-001NI0250	
300	12"	78	59	VGB4400-001NI0300	
350	14"	78	123	VGB4400-001NI0350	
400	16"	102	156	VGB4400-001NI0400	



Version **(ACS)** disponible sur demande  
ACS model available on request



VGB3400N-08NI | VGB4400-08NI

Réducteur manuel | Gearbox actuator

Vanne à guillotine bidirectionnelle à réducteur manuel  
 Bidirectional type knife gate valve with gearbox



**Corps :** Voir tableau  
**Pelle :** Inox 304  
**Siège :** NBR  
**Presse Etoupe :**  
 - 2 tresses PTFE  
 - 1 torique NBR  
**Raccordement :**  
 Entre-brides PN10  
**Pression de service :**  
 DN450 : 7 bar  
 DN500-600 : 4 bar  
**Température de service :**  
 -10°C/+80°C  
**Manceuvre :** Réducteur à volant ou motorisable

**Body:** See on the table  
**Gate:** Stainless steel 304  
**Seat:** NBR  
**Packing:**  
 - 2 PTFE packing  
 - 1 NBR O-ring  
**Connection:**  
 Between flanges PN10  
**Working pressure:**  
 DN450: 7 bar  
 DN500-600: 4 bar  
**Working temperature:**  
 -10°C/+80°C  
**Operation :** Manual gearbox with handwheel or ISO top flange for electric actuator connection

DN		L (mm)	Kg	Fonte ductile Ductile Iron (GGG50)	
mm	inch			Ref.	
450	18"	114	243	VGB4400-08NI0450	
500	20"	127	328	VGB4400-08NI0500	
600	24"	154	444	VGB4400-08NI0600	

VGB3400N-03NI | VGB4400-03NI

Vérin pneumatique | Pneumatic actuator

Vanne à guillotine bidirectionnelle à vérin pneumatique double effet  
 Bidirectional type knife gate valve with double-acting pneumatic actuator



**Corps :** Voir tableau  
**Pelle :** Inox 304  
**Siège :** NBR  
**Presse Etoupe :**  
 - 2 tresses PTFE  
 - 1 torique NBR  
**Raccordement :**  
 Entre-brides PN10  
**Pression de service :**  
 DN50-250 : 10 bar  
 DN300-400 : 7 bar  
**Température de service :**  
 -10°C/+80°C

**Body:** See on the table  
**Gate:** Stainless steel 304  
**Seat:** NBR  
**Packing:**  
 - 2 PTFE packing  
 - 1 NBR O-ring  
**Connection:**  
 Between flanges PN10  
**Working pressure:**  
 DN50-250: 10 bar  
 DN300-400: 7 bar  
**Working temperature:**  
 -10°C/+80°C

DN		L (mm)	Kg	Fonte ductile Ductile Iron (GGG50)	
mm	inch			Ref.	
50	2"	43	8	VGB4400-03NI0050	
65	2 1/2"	46	9	VGB4400-03NI0065	
80	3"	46	10	VGB4400-03NI0080	
100	4"	52	13	VGB4400-03NI0100	
125	5"	56	18	VGB4400-03NI0125	
150	6"	56	21	VGB4400-03NI0150	
200	8"	60	36	VGB4400-03NI0200	
250	10"	68	57	VGB4400-03NI0250	
300	12"	78	77	VGB4400-03NI0300	
350	14"	78	138	VGB4400-03NI0350	
400	16"	102	173	VGB4400-03NI0400	
450	18"	114	237	VGB4400-03NI0450	
500	20"	127	291	VGB4400-03NI0500	
600	24"	154	-	VGB4400-03NI0600	



Utiliser de l'air comprimé lubrifié conforme à la classe de pureté ISO 8573-1  
 Use lubricated compressed air conforming to the purity class ISO 8573-1

VGB4400-004NI

Embase ISO | ISO mounting plate

Vanne à guillotine bidirectionnelle avec platine ISO motorisable  
 Bidirectional type knife gate valve with ISO mounting plate for electric actuator



**Corps :** Voir tableau  
**Pelle :** Inox 304  
**Siège :** NBR  
**Presse Etoupe :**  
 - 2 tresses PTFE  
 - 1 torique NBR  
**Raccordement :**  
 Entre-brides PN10  
**Pression de service :**  
 DN50-250 : 10 bar  
 DN300-450 : 7 bar  
 DN500-600 : 4 bar  
**Température de service :**  
 -10°C/+80°C

**Body:** See on the table  
**Gate:** Stainless steel 304  
**Seat:** NBR  
**Packing:**  
 - 2 PTFE packing  
 - 1 NBR O-ring  
**Connection:**  
 Between flanges PN10  
**Working pressure:**  
 DN50-250: 10 bar  
 DN300-450: 7 bar  
 DN500-600: 4 bar  
**Working temperature:**  
 -10°C/+80°C

DN		L (mm)	Kg	Fonte ductile Ductile Iron (GGG50)	
mm	inch			Ref.	
50	2"	43	8	VGB4400-004NI0050	
65	2 1/2"	46	9	VGB4400-004NI0065	
80	3"	46	10	VGB4400-004NI0080	
100	4"	52	13	VGB4400-004NI0100	
125	5"	56	18	VGB4400-004NI0125	
150	6"	56	21	VGB4400-004NI0150	
200	8"	60	36	VGB4400-004NI0200	
250	10"	68	57	VGB4400-004NI0250	
300	12"	78	77	VGB4400-004NI0300	
350	14"	78	138	VGB4400-004NI0350	
400	16"	102	173	VGB4400-004NI0400	
450	18"	114	243	VGB4400-004NI0450	
500	20"	127	328	VGB4400-004NI0500	
600	24"	157	444	VGB4400-004NI0600	



**Moteur électrique page 119**  
**Electric actuator on page 119**



# VG PELLE TRAVERSANTE

## THROUGH CONDUIT KNIFE GATE VALVE



### Pas de zone de rétention

Cette vanne est constituée d'un corps en deux parties sans zone de rétention avec deux joints de siège qui permettent une étanchéité bidirectionnelle. Elle est particulièrement adaptée en papèterie, en sortie de pulpeur ou sous des silos.

### ✓ No retention zone

This valve has a two-piece body without a retention zone, with two seat gaskets, allowing a bidirectional tightness. It is especially adapted for the pulp and paper industry, at pulp outlets or under silos.



**Idéal pour fluides très épais (pâte à papier...)**  
Ideal for very thick fluids (paper pulp...)

### VANNE A GUILLOTINE PELLE TRAVERSANTE

#### "Nouvelle technologie" :

Amélioration du guidage de la pelle.

#### Through conduit knife gate valve

#### "New technology":

Improved gate guiding.



**L'ensemble des accessoires sont identiques aux VG standards.**

See all accessories for standard KGV.

### VGT3400-00 | VGT4400-00

Vanne à guillotine à pelle traversante à volant

Through conduit type knife gate valve with handwheel



Corps : Voir tableau

Pelle : Inox 304

Siège : NBR

Presse Etoupe :

- 2 tresses PTFE

- 1 torique NBR

Raccordement :

Entre-brides PN10

Pression de service :

DN50-250 : 10 bar

Température de service :

-10°C/+80°C

Sur demande :

- Moteur électrique

- DN > 200

Body: See on the table

Gate: Stainless steel 304

Seat: NBR

Packing:

- 2 PTFE packing

- 1 NBR O-ring

Connection:

Between flanges PN10

Working pressure:

DN50-250: 10 bar

Working temperature:

-10°C/+80°C

On request:

- Electric actuator

- DN > 200

DN		L (mm)	Kg	Fonte ductile Ductile Iron (GGG50)
mm	inch			Ref.
50	2"	40	13	VGT4400-00NI0050
65	2 1/2"	40	15	VGT4400-00NI0065
80	3"	50	19	VGT4400-00NI0080
100	4"	50	23	VGT4400-00NI0100
125	5"	50	29	VGT4400-00NI0125
150	6"	60	38	VGT4400-00NI0150
200	8"	60	65	VGT4400-00NI0200

### VGT3400-03 | VGT4400-03

Vanne à guillotine à pelle traversante à vérin pneumatique double effet

Through conduit type knife gate valve with double-acting pneumatic actuator



Corps : Voir tableau

Pelle : Inox 304

Siège : NBR

Presse Etoupe :

- 2 tresses PTFE

- 1 torique NBR

Raccordement :

Entre-brides PN10

Pression de service :

DN50-250 : 10 bar

DN300-400 : 6 bar

Température de service :

-10°C/+80°C

Body: See on the table

Gate: Stainless steel 304

Seat: NBR

Packing:

- 2 PTFE packing

- 1 NBR O-ring

Connection:

Between flanges PN10

Working pressure:

DN50-250: 10 bar

DN300-400: 6 bar

Working temperature:

-10°C/+80°C

DN		L (mm)	Kg	Fonte ductile Ductile Iron (GGG50)
mm	inch			Ref.
50	2"	40	10	VGT4400-03NI0050
65	2 1/2"	40	12	VGT4400-03NI0065
80	3"	50	18	VGT4400-03NI0080
100	4"	50	24	VGT4400-03NI0100
125	5"	50	31	VGT4400-03NI0125
150	6"	60	39	VGT4400-03NI0150
200	8"	60	67	VGT4400-03NI0200
250	10"	70	126	VGT4400-03NI0250
300	12"	70	138	VGT4400-03NI0300
350	14"	96	200	VGT4400-03NI0350
400	16"	100	281	VGT4400-03NI0400



### Equipé de carters de protection Inox

Equipped with Stainless steel protective housings



# VG SOUS SILO

## UNDER SILO KNIFE GATE VALVE

### VANNE À GUILLOTINE SOUS SILO

DN150 à 400

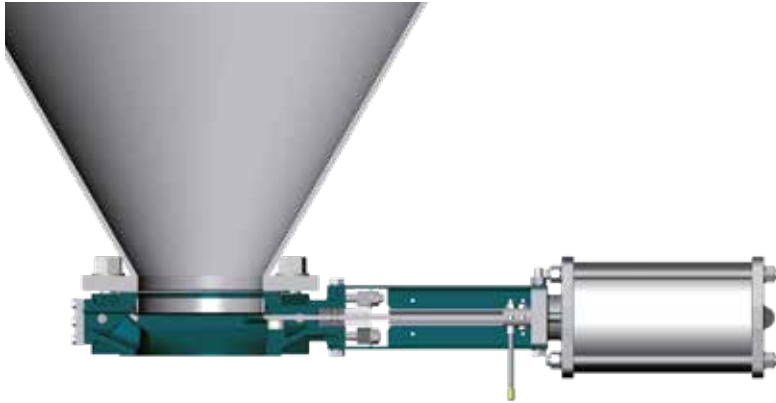

**Idéal pour silos de grains, cimenteries, pulvérulents**  
Ideal for grain silos, cement factories, powders

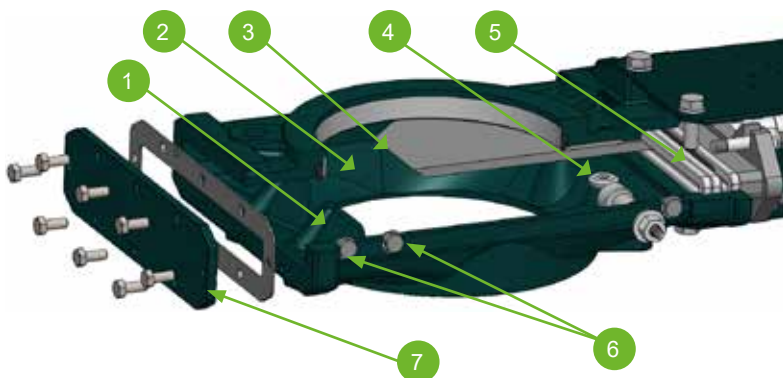

### Under silo knife gate valves

DN150 up to 400

- 1 Butées de pelle : pas de zone de rétention.  
Steel reinforced gate: no retention zone.
- 2 Corps large et évasé : pas d'accumulation, passage du produit facilité.  
Wide body: ease of product evacuation.
- 3 Pelle plate et tranchante avec chanfrein : attaque franche.  
Sharp gate with beveled edge straight cut.
- 4 Guidage de la pelle par doigts PTFE : peu de frottements.  
Gate guided by PTFE rubbing plates: low friction.
- 5 Tresse effet racleur : nettoyage de la pelle lors des mouvements.  
Packing with scraper effect: ease of gate cleaning.
- 6 Trous de soufflage : nettoyage du corps simplifié.  
Flushing holes: easy cleaning of the body.
- 7 Fond démontable pour nettoyer sans démonter la vanne.  
Removable bottom for cleaning without dismantling the valve.

**Étanche aux poudres, ne pas utiliser avec de l'eau.**  
Powder tight, do not use with water.

### VGS3400-03 | VGS4400-03

### Sous silo | Under silo

Vanne à guillotine sous silo à vérin pneumatique double effet

Under silo knife gate valve with double-acting pneumatic actuator



Corps : Voir tableau  
Pelle : Inox 304  
Siège : NBR  
Raccordement : Entre-brides PN10  
Pression de service : DN150: 2,5 bar  
DN200 : 2 bar  
DN250-300 : 1,5 bar  
DN350-400 : 1,3 bar  
Working temperature: -10°C/+80°C  
Trous de soufflage : Nettoyage du corps simplifié  
Fond démontable

Body: See on the table  
Gate: Stainless steel 304  
Seat: NBR  
Connection: Between flanges PN10  
Working pressure: DN150: 2,5 bar  
DN200: 2 bar  
DN250-300: 1,5 bar  
DN350-400: 1,3 bar  
Working temperature: -10°C/+80°C  
Flushing holes: Body cleaning simplified  
Dismantling bottom

CE

**Ex** ATEX sur demande  
ATEX on request

DN		L (mm)	Kg	Fonte ductile Ductile iron (GGG50)
mm	inch			Ref.
150	6"	76	23	VGS4400-03NI0150
200	8"	89	31	VGS4400-03NI0200
250	10"	114	65	VGS4400-03NI0250
300	12"	114	81	VGS4400-03NI0300
350	14"	96	200	VGS4400-03NI0350
400	16"	100	281	VGS4400-03NI0400



**Equipé de carters de protection inox**  
Equipped with Stainless steel protective housings

# AUTRES MODÈLES | OTHER MODELS

VG À MANCHON | VG HAUTE PRESSION  
PINCH KNIFE GATE VALVE | HIGH PRESSURE KNIFE GATE VALVE

**DISPONIBLE SUR DEMANDE | ON REQUEST**

(Étude particulière selon vos exigences pour un produit le plus adapté, nous consulter)  
(Contact us for a specific study according to your needs for a better adapted product)

## GAMME VGP

**A manchon | Pinch**

Vanne à guillotine à manchon  
Pinch knife gate valve



**Mines**  
Mining industry

Application : Vanne adaptée aux transports de produits abrasifs  
Prix sur demande

Application: Valve used for transport of abrasive products  
Price on request



## GAMME VG

**Haute température | High temperature**

Vanne à guillotine T° max 500°C  
Max Temperature 500°C



Application : Vanne adaptée aux très hautes températures  
Prix sur demande

Application: Valve used for very high temperature  
Price on request

## GAMME VGH

**Haute pression | High pressure**

Vanne à guillotine à chapeau boulonné  
Bolted bonnet knife gate valve

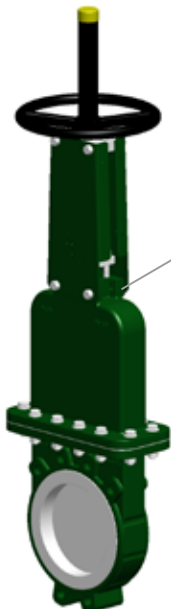

**Pour haute pression**  
For high pressure

Application : Vanne appropriée aux liquides clairs ou faiblement chargés à des pressions élevées (40 bar)  
Prix sur demande

Application: Valve used for clean water or with a low concentration of solids at high pressure (40 bar)  
Price on request

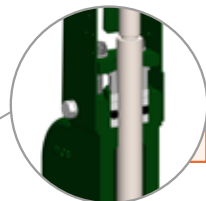

## GAMME VGB

**Biogaz | Biogas**

Vanne à guillotine bidirectionnelle spéciale biogaz  
Biogas bidirectional knife gate valve



**Pour applications biogaz**  
For biogas applications

### ASSEMBLAGE SPÉCIAL

Kit de tresses renforcées en fibres Aramide

Application BIOGAZ pour une performance maximale :  
- excellente tenue mécanique  
- bonne résistance sur fluides abrasifs  
- auto lubrifiante  
- tresse exempte de silicone

### SPECIAL ASSEMBLY

Packing reinforced with Aramide fibers

BIOGAS application for maximum performance:  
- Excellent mechanical strength  
- Good resistance to abrasive fluids  
- Self-lubricating  
- Packing silicone-free



**Modèle VGB pages 111-112**  
VGB type on pages 111-112



**Kit tresses BIOGAZ page 134**  
Special biogas packing on page 134



# KIT VG

## ACCESSOIRES, OPTIONS ET MOTORISATIONS ACCESSORIES, OPTIONS AND ACTUATORS



Commandes pour vannes à guillotine | Knife gate valve actuators

### CARRÉ DE FONTAINIER CONIQUE | SQUARE ADAPTOR

Carré de manœuvre pour vanne à guillotine tige non montante  
Square adaptor for non-rising stem knife gate valve



Matière : Fonte FT25  
Dimensions : 30x30

Material: Cast Iron FT25  
Dimensions: 30x30

DN		Ref.
mm	inch	
50-150	2"-6"	VGCARRENM1
200-300	8"-12"	VGCARRENM2
350-450	14"-18"	VGCARRENM3

DN supérieurs sur demande / Other DN on request



Voir clé de fontainier page 137  
See lever wrench on page 137

### KIT VOLANT À CHAÎNE | CHAINWHEEL KIT

Volant à chaîne pour vanne à guillotine  
Chainwheel kit for knife gate valve



Montage sur vanne à guillotine tige montante  
Assembly on rising-stem only



Composé de :  
- Entretoise acier au carbone  
- Volant à chaîne acier au carbone  
- Guide chaîne Inox 304

Comprised of:  
- Carbon steel spacer  
- Carbon steel chainwheel  
- Stainless steel 304 guide

Remplace le volant standard

Replaces the standard handwheel

DN		Ref.
mm	inch	
50 - 150	2"-6"	300000014
200 - 300	8"-12"	300000015
350 - 450	14"-18"	300000016
500 - 600	20"-24"	300000017

#### EN OPTION | OPTION

Chaîne acier ou inox / Prix au mètre  
Steel or Stainless steel chain / Price per meter

Matière / Material	Ref.
Acier / Steel	VGCHAINE-AC01
Inox / Stainless steel	VGCHAINE-IN01



Support non inclus  
Support not included

Très utilisé pour les installations en hauteur avec des accès difficiles. Le volant se place en position verticale.  
Widely used in high installations with difficult access. The steering wheel is placed in a vertical position.



**KIT SYSTEME CADENASSABLE | LOCKING KIT**

**Kit VG à levier / volant cadenassable**

Lever or handwheel locking kit



**Levier :**

- Cadenas laiton
- Plaque de verrouillage VG à levier inox 304
- Position ouverte et fermée.

**Volant :**

- Cadenas
- Plaque de verrouillage VG à volant inox 304
- Câble de consignation

**Lever:**

- Brass locker
- Stainless steel 304 locking plate for VG with lever
- Open and closed position.

**Handwheel:**

- Brass locker
- Stainless steel 304 locking plate for VG with handwheel
- Lockout cable

DN		Ref.	Modèle / Model
mm	inch		
50 - 300	2" - 12"	300200316	LEVIER / LEVER
50-150	2"-6"	300200347	VOLANT / HANDWHEEL
200-300	8"-12"	300200348	VOLANT / HANDWHEEL
350-600	14"-24"	300200349	VOLANT / HANDWHEEL

**VERIN | PNEUMATIC ACTUATOR**

**Vérin double effet**

Double-acting pneumatic actuator



**Pression de service :** 5 à 7 bar (air lubrifié)  
**Corps et flasques :** Aluminium

**Working pressure:** 5 to 7 bar (lubricated air)  
**Body and flanges:** Aluminium

DN		Ref.	Prix / Price	DN		Ref.
mm	inch			mm	inch	
50	2"	VGVERINDE-0050	198,00€	350	14"	VGVERINDE-0350
65	2"1/2	VGVERINDE-0065	200,00€	400	16"	VGVERINDE-0400
80	3"	VGVERINDE-0080	208,00€	450	18"	VGVERINDE-0450
100	4"	VGVERINDE-0100	251,00€	500	20"	VGVERINDE-0500
125	5"	VGVERINDE-0125	360,00€	600	24"	VGVERINDE-0600
150	6"	VGVERINDE-0150	384,00€	700	28"	VGVERINDE-0700
200	8"	VGVERINDE-0200	580,00€	800	32"	VGVERINDE-0800
250	10"	VGVERINDE-0250	908,00€	1000	40"	VGVERINDE-1000
300	12"	VGVERINDE-0300	1.014,00€			

→ Pièces détachées pour vérin | Actuator spare parts

**KIT DE JOINTS | GASKETS KIT**

Kit de joints pour vérin double effet

Gaskets kit for double-acting pneumatic actuator



- 2 joints toriques / 2 o-rings
- 1 joint cache poussières / 1 dust cap
- 1 joint d'étanchéité / 1 gasket
- 1 o-ring de piston / 1 piston o-ring

	DN		Ref.
	mm	inch	
50/65/80	2"	2" 1/2 / 3"	VGKITVERINDE-0050
100	4"		VGKITVERINDE-0100
125/150	5"	6"	VGKITVERINDE-0125
200	8"		VGKITVERINDE-0200
250/300	10"	12"	VGKITVERINDE-0250
350/400/450	14"	16" / 18"	VGKITVERINDE-0350
500	20"		VGKITVERINDE-0500
600	24"		VGKITVERINDE-0600
700	28"		VGKITVERINDE-0700

**PISTON | PISTON**

Piston pour vérin double effet

Piston for double-acting pneumatic actuator



Matière : Nitrile

Material: Nitrile

	DN		Ref.
	mm	inch	
50/65/80	2"	2" 1/2 / 3"	VGPISTOVERIN-0050
100	4"		VGPISTOVERIN-0100
125/150	5"	6"	VGPISTOVERIN-0125
200	8"		VGPISTOVERIN-0200
250/300	10"	12"	VGPISTOVERIN-0250
350/400/450	14"	16" / 18"	VGPISTOVERIN-0350
500/600	20"	24"	VGPISTOVERIN-0500

**TIRANTS | THREADED RODS**

Kit tirants INOX pour VG vérin

Stainless steel threaded rods for knife gate valve actuators



**Idéal sur ambiance corrosive**  
For corrosive environments

DN			Inox 304 (A2)	Inox 316 (A4)
	mm	inch	Ref.	Ref.
50	2"		300160018	300160032
65	2" 1/2		300160019	300160033
80	3"		300160020	300160034
100	4"		300160021	300160035
125	5"		300160022	300160036
150	6"		300160023	300160037
200	8"		300160024	300160038
250	10"		300160025	300160039
300	12"		300160026	300160040
350	14"		300160027	300160041
400	16"		300160028	300160042
450	18"		300160029	300160043
500	20"		300160030	300160044
600	24"		300160031	300160045

DN supérieurs sur demande / Other DN on request



En stock / Available



Avec délais / Not in stock

➔ (Suite) Commandes pour vanne à guillotine | Knife gate valve actuations

**COMMANDE DE SECOURS | EMERGENCY HANDWHEEL**

Commande manuelle de secours pour vanne à guillotine standard à actionneur pneumatique  
Manual emergency handwheel for standard knife gate valve with pneumatic actuator



**Commande manuelle de secours à goupiller**  
**Manual emergency control with pin**



Composé de :  
- 1 vérin pneumatique avec tige sortante inox + volant  
- 2 plaques support acier peint époxy

Comprised of:  
- 1 pneumatic actuator with Stainless steel rising-stem + handwheel  
- 2 Epoxy-coated steel support plates



Prix à ajouter à la vanne à volant  
Price to be added to standard valve with handwheel

DN		Ref.
mm	inch	
50	2"	KITVGVERINDECMS-0050
65	2"1/2	KITVGVERINDECMS-0065
80	3"	KITVGVERINDECMS-0080
100	4"	KITVGVERINDECMS-0100
125	5"	KITVGVERINDECMS-0125
150	6"	KITVGVERINDECMS-0150
200	8"	KITVGVERINDECMS-0200
250	10"	KITVGVERINDECMS-0250
300	12"	KITVGVERINDECMS-0300
350	14"	KITVGVERINDECMS-0350
400	16"	KITVGVERINDECMS-0400
450	18"	KITVGVERINDECMS-0450
500	20"	KITVGVERINDECMS-0500
600	24"	KITVGVERINDECMS-0600

DN supérieurs sur demande / Other DN on request

**U04 - MOTEUR VG STANDARD | U04 AUMA ACTUATOR FOR STANDARD KNIFE GATE VALVE**

Moteur électrique AUMA pour vanne à guillotine  
3-phase AUMA actuator for knife gate valve



Autres tensions ou options sur demande  
Other voltages or options on request



Tension : 3P 400V / 50 Hz  
Application : Tout ou rien  
- 2 contacts fin de course  
- 2 limiteurs de couple  
- 1 résistance de chauffe  
Commande manuelle de secours  
IP68

Voltage: 3P 400V / 50 Hz  
Application: On/off  
- 2 limit switches  
- 2 torque limiters switches  
- 1 heat resistor  
Emergency handwheel  
IP68

Moteur monté sur réducteur motorisable  
Actuator mounted on motorizable gearbox

VG standard (VG3400 / VG4400 / VG6400) Standard knife gate valve		
DN		Ref.
mm	Type	
50-100	7.2	VGMOTELEC-SA07.21
125 150 200 300	7.6	VGMOTELEC-SA07.61
250 350 400	10.2	VGMOTELEC-SA10.21
450-600	14.2	VGMOTELEC-SA14.21
700		
800 900 1000	10.2	SA102U04B3TOR180T
1200	14.2	SA142U04B3TOR180T

VGB (bidirectionnelle) Bidirectional type knife gate valve		
DN		Ref.
mm	Type	
50-100	7.2	300190232
125-150	7.6	300190233
200-300	10.2	300190234
350-500	14.2	300190236
600	14.6	300190237



Voir guide technique pages 318  
See technical guide on pages 318



**Electrodistributeur NON ATEX | NON-ATEX solenoid valves**

**ELECTRODISTRIBUTEUR EN LIGNE NON ATEX | NON-ATEX IN LINE SOLENOID VALVE**

**Monostable**

Electrodistributeur ASCO monostable G551A017 G1/4 montage en ligne NON ATEX  
 ASCO model G551A017 G1/4 NON-ATEX solenoid valve monostable in-line editing



Commande électropneumatique (avec commande manuelle)  
 5/2 monostable rappel ressort  
 Raccordement G1/4 (en ligne sans bobine)  
 Avec commande manuelle  
 IP65  
 Aluminium anodisé noir  
 Pression différentielle : 2-10bar  
 Plage de température : -25°C / +60°  
 Débit : 860 l/min

Electro-pneumatic control (with manual override)  
 5/2 monostable spring return  
 Connection G1/4  
 With manual override  
 IP65  
 Anodized aluminium  
 Differential pressure: 2-10bar  
 Temperature range: -25°C / +60°C  
 Flow rate: 860 l/min

Voltage	Ref.
24VAC	300180079
24VCC	300180080
48VAC	300180081
48VCC	300180082
230VAC	300180083



Kit composé de :  
 - Electrodistributeur en ligne mono  
 - Bobine + connecteur  
 - Raccords coudés auto-bloquants  
 - Tube rilsan + vis

Kit  
 - Solenoid valve  
 - Coil + connector  
 - Connection  
 - Rilsan tube internal + screws

**ELECTRODISTRIBUTEUR EN LIGNE GRAND DEBIT NON ATEX | NON-ATEX IN-LINE HIGH FLOW SOLENOID VALVE**

**Monostable**

Electrodistributeur ASCO monostable G553A017 G1/2 montage en ligne NON ATEX  
 ASCO NON-ATEX model G553A017 G1/2 solenoid valve monostable in-line editing



Commande électropneumatique (avec commande manuelle)  
 5/2 monostable rappel ressort  
 Raccordement G1/2  
 IP65  
 Bobine + connecteur  
 Aluminium anodisé noir  
 Pression différentielle : 2-10bar  
 Plage de température : -25°C / +60°  
 Débit : 3800 l/min

Electro-pneumatic control (with manual override)  
 5/2 monostable spring return  
 Connection G1/2  
 IP65  
 Coil + connector  
 Anodized aluminium  
 Differential pressure: 2-10bar  
 Temperature range: -25°C / +60°C  
 Flow rate: 3800 l/min

Voltage	Ref.
24VAC/50-60 Hz	G553A017S3AN
24VCC	G553A017S3D2
48VAC/50-60 Hz	G553A017S3AP
48VCC	G553A017S3D3
115VAC/50 Hz	G553A017S3A5
230VAC/50 Hz	G553A017S3A8



**Electrotributeur grand débit : 3800 L/min (à 6 bar)**  
**High flow solenoid valve : 3800 L/min (at 6 bar)**

POUR MODELES A PARTIR DU DN500  
 For models from the DN500

**ELECTRODISTRIBUTEUR EN LIGNE NON ATEX | NON-ATEX IN LINE SOLENOID VALVE**

**Bistable**

Electrodistributeur ASCO bistable G551A018 G1/4 montage en ligne NON ATEX  
 ASCO model G551A018 G1/4 NON-ATEX solenoid valve bistable in-line editing



Commande électropneumatique (avec commande manuelle)  
 5/2 bistable commandé par 2 bobines  
 Raccordement G1/4 (en ligne sans bobine)  
 Avec commande manuelle  
 IP65  
 Bobine + connecteur  
 Aluminium anodisé noir  
 Pression différentielle : 2-10bar  
 Plage de température : -25°C / +60°  
 Débit : 860 l/min

Electro-pneumatic control (with manual override)  
 5/2 bistable controlled by 2 coils  
 Connection G1/4  
 With manual override  
 IP65  
 Coil + connector  
 Anodized aluminium  
 Differential pressure: 2-10bar  
 Temperature range: -25°C / +60°C  
 Flow rate: 860 l/min

Voltage	Ref.
24VAC	G551A018MS.24/50-60
24VCC	G551A018MS.24/DC
48VCC	G551A018MS.48/50-60
48VAC	G551A018MS.48/DC
230VCC	G551A018MS.230/50



**ELECTRODISTRIBUTEUR EN LIGNE GRAND DEBIT NON ATEX | NON-ATEX IN LINE HIGH FLOW SOLENOID VALVE**

**Bistable**

Electrodistributeur ASCO bistable G553A018 G1/2 montage en ligne NON ATEX  
 ASCO model G553A018 G1/2 NON-ATEX solenoid valve bistable in-line editing



Commande électropneumatique (avec commande manuelle)  
 5/2 bistable  
 Raccordement G1/2  
 IP65  
 Bobine + connecteur  
 Aluminium anodisé noir  
 Pression différentielle : 2-10bar  
 Plage de température : -25°C / +60°  
 Débit : 3800 l/min

Electro-pneumatic control (with manual override)  
 5/2 bistable  
 Connection G1/2  
 IP65  
 Coil + connector  
 Anodized aluminium  
 Differential pressure: 2-10bar  
 Temperature range: -25°C / +60°C  
 Flow rate: 3800 l/min

Voltage	Ref.
24VAC	G553A018MS.24/50-60
24VDC	G553A018MS.24/DC
48VAC	G553A018MS.48/50-60
48VDC	G553A018MS.48/DC
230VAC	G553A018MS.230/50



**Electrotributeur grand débit : 3800 L/min (à 6 bar)**  
**High flow solenoid valve : 3800 L/min (at 6 bar)**

POUR MODELES A PARTIR DU DN500  
 For models from the DN500

Electrodistributeurs ATEX | ATEX solenoid valves

Voir guide technique page 341  
See technical guide on page 341

Des produits conformes à la directive ATEX 2014/34/UE

Products comply with the ATEX directive 2014/34/EU

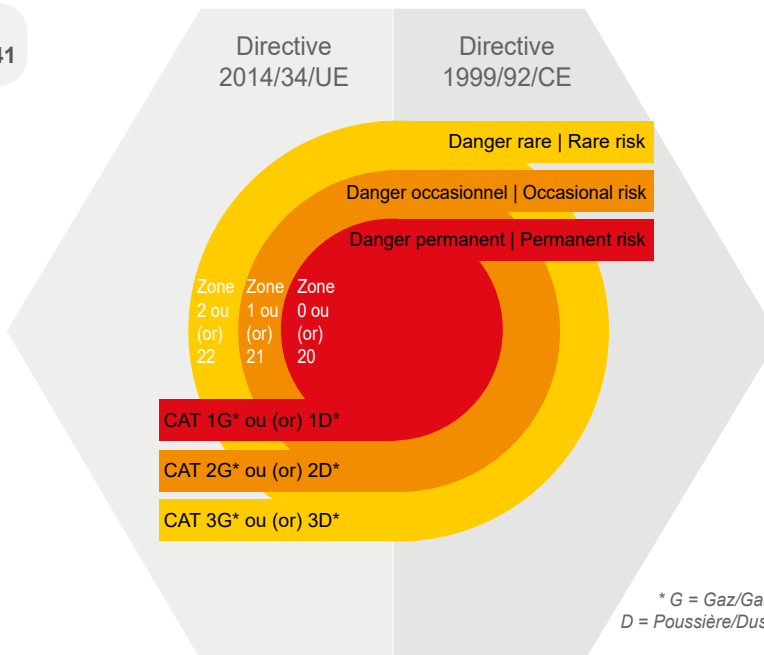
ELECTRODISTRIBUTEUR EN LIGNE ATEX | ATEX IN LINE SOLENOID VALVE

Electrodistributeur ASCO montage en ligne ATEX  
ASCO ATEX solenoid valve in-line editing



Commande électropneumatique (sans commande override)  
5/2 monostable rappel ressort  
Raccordement G1/4  
Distributeur avec bobine époxy ATEX IP65  
Aluminium anodisé noir  
Pression différentielle : 2-10bar  
Plage de température : -10°C / +50°  
Débit : 860 l/min (à 6 bar)  
Protection Ex tc

Electro-pneumatic control (without manual override)  
5/2 monostable spring return  
Connection G1/4  
Distributor with ATEX epoxy coil IP65  
Anodized aluminium  
Differential pressure: 2-10bar  
Temperature range: -10°C / +50°C  
Flow rate: 860 l/min (at 6 bar)  
Ex tc protection

Voltage	Ref.
24VDC	SGG551A017.24/DC
230VAC	SGG551A017.230/50-60

3G T4 Zone 2  
3D T115°C Zone 22

ELECTRODISTRIBUTEUR EN LIGNE ATEX | ATEX IN LINE SOLENOID VALVE

Electrodistributeur ASCO montage en ligne ATEX  
ASCO ATEX solenoid valve in-line editing



Commande électropneumatique (sans commande manuelle)  
5/2 monostable rappel ressort  
Raccordement G1/4  
Distributeur avec bobine intégrée dans un boîtier Aluminium antidéflagrant IP67  
Aluminium anodisé noir  
Pression différentielle : 2-10bar  
Plage de température : -25°C / +60°  
Débit : 860 l/min (à 6 bar)  
Protection Ex d et Ex tb

Electro-pneumatic control (without manual override)  
5/2 monostable spring return  
Connection G1/4  
Distributor with coil integrated in an explosion proof Aluminium box IP67  
Anodized aluminium  
Differential pressure: 2-10bar  
Temperature range: -25°C / +60°C  
Débit: 860 l/min (at 6 bar)  
Ex d and Ex tb protection

Voltage	Ref.
24VDC	LPKF6551B317.24/DC
230VAC	LPKF6551B317.230/50

2G T6 Zone 1  
2D T135°C Zone 21





## ELECTRODISTRIBUTEUR EN LIGNE ATEX | ATEX IN LINE SOLENOID VALVE

## Electrodistributeur ASCO montage en ligne ATEX

ASCO ATEX solenoid valve in-line editing



Commande électropneumatique (sans commande manuelle)  
5/2 monostable rappel ressort  
Raccordement G1/4  
Distributeur avec bobine ATEX  
IP65  
Aluminium anodisé noir  
Pression différentielle : 2-10bar  
Plage de température : -25°C / +60°  
Débit : 860 l/min (à 6 bar)  
Protection EX ia et Ex ib (sécurité intrinsèque)

Electro-pneumatic control (without manual override)  
5/2 monostable spring return  
Connection G1/4  
Distributor with ATEX epoxy coil  
IP65  
Anodized aluminium  
Differential pressure: 2-10bar  
Temperature range: -25°C / +60°C  
Débit: 860 l/min (at 6 bar)  
EX ia and Ex ib protection (intrinsic safety)

Voltage	Ref.
24VDC	LISCG551B217.24/DC



2G T6 Zone 1  
2D T85°C Zone 21



## SILENCIEUX | SILENCER

## Silencieux d'échappement pour électrodistributeur

Silencer for solenoid valve



Corps : Laiton  
Raccordement : Fileté BSP

Body: Brass  
Connection: Male BSP

DN	Ref.
1/8"	EDSILENCE-0005
1/4"	EDSILENCE-0008
3/8"	EDSILENCE-0010



Réduit le bruit d'échappement à la sortie de l'air.  
Decrease the exhaust noise at the air outlet.

## FREIN | THROTTLE

## Frein d'échappement réglable

Adjustable throttle valve



Corps : Laiton  
Raccordement : Mâme BSP

Body: Brass  
Connection: Male BSP

DN	Ref.
1/8"	EDFREIN-0005
1/4"	EDFREIN-0008



Ralentit le temps de manoeuvre des vannes (ouverture et/ou fermeture)  
Slows the valve's operating time (opening and / or closing)

## REGULATEUR | REGULATOR

## Régulateur pour air comprimé

Regulator for compressed air



Corps : Aluminium  
Tube : Polycarbonate  
Température de service : -10/+60°C  
Pression de service : 0,5 à 10 bar  
Précision du régulateur : 0,2 bar  
Raccordement : Femelle BSP  
Avec manomètre et support  
Voir les courbes de débits (L/min) selon la pression d'entrée et de sortie sur le passeport technique

Body: Aluminium  
Tube: Polycarbonate  
Working temperature: -10/+60°C  
Working pressure: 0,5 to 10 bar  
Regulator precision: 0,2 bar  
Connection: Female BSP  
With pressure gauge and mounting kit  
Consult the technical data sheet for the flows curve.

DN	Ref.
1/4"	FRL1733-0008
3/8"	FRL1733-0010
1/2"	FRL1733-0015

## FILTRE REGULATEUR | REGULATOR FILTER

## Filtre régulateur pour air comprimé

Filter + regulator for compressed air



Corps : Aluminium  
Tube : Polycarbonate  
Filtration : 5µ  
Température de service : 0/+50°C  
Pression de service : 1/4"-1/2" : 10 bar  
1 cartouche de filtration

Body: Aluminium  
Tube: Polycarbonate  
Filtration: 5µ  
Working temperature: 0/+50°C  
Working pressure: 1/4"-1/2": 10 bar  
1 filter cartridge

DN	Ref.
1/4"	FRL1700A-0008

NEW



FILTRE REGULATEUR LUBRIFICATEUR | LUBRICATOR REGULATOR FILTER

Filtre régulateur et lubrificateur pour air comprimé  
Lubricator filter + regulator for compressed air



Corps : Aluminium  
Tube : Polycarbonate  
Filtration : 5µ  
Température de service : 0/+50°C  
Pression de service : 1/4"-1/2" : 10 bar  
2 cartouches de filtration



Body: Aluminium  
Tube: Polycarbonate  
Filtration: 5µ  
Working temperature: 0/+50°C  
Working pressure: 1/4"-1/2": 10 bar  
2 filter cartridges

DN	Ref.
1/4"	FRL1720A-0008



**Faible encombrement. Garantie un apport d'air lubrifié de qualité et assure le rendement des équipements.**  
Small footprint, low mass. Guarantees quality lubricated air supply and ensures the performance of the equipment.



**Electropositionneurs numériques | Digital electropositioners**



**Un électropositionneur peut coûter jusqu'à 20% de son prix d'achat par an en air comprimé ! Le modèle SIPART de Siemens® offre une faible consommation d'air (36 NI/h) ce qui le place parmi le meilleur du marché.**  
An electro pneumatic positioner can cost up to 20% of its purchase price in compressed air per year! The Siemens SIPART® offers low air consumption (36NI/h), placing it as one of the best on the market.

ELECTROPOSITIONNEUR POUR VERIN DOUBLE EFFET | ELECTROPOSITIONER FOR DOUBLE-ACTING ACTUATOR

Electropositionneur numérique modèle SIEMENS SIPART - PS2 pour vérin double effet type  
SIEMENS electropositioner type SIPART -PS2 for double-acting actuator type



Type : Electro-pneumatique pour vérin double effet  
Température de fonctionnement : -30°C/+80°C  
Pression d'alimentation : 1,4 à 7 bar  
Boîtier : Macrolon®  
IP66  
Affichage : Par écran LCD  
Signal de commande : 4 - 20 mA  
Air comprimé conforme ISO 8573-1 CLASSE 2  
Comprend arcade Inox pour montage sur vérin, entraineur pour vérin, vis, rondelle.

Type: Electro-pneumatic for double-acting actuator  
Service temperature: -30°C/+80°C  
Air supply: 1.4 up to 7 bar  
Body: Macrolon®  
IP66  
Display: LCD screen  
Input signal: 4-20 mA  
Compressed air in accordance with ISO 8573-1 CLASS 2  
Includes Stainless steel arch for mounting on the actuator, bolts.



**Kit d'adaptation inox inclus avec carters de protection**  
Stainless steel mounting kit included with protective housing



DN		POSSIE-DE	POSSIE-DE + POSSIE-RE- COPIE 4-20MA	POSSIE-DE + POSSIE-FDC	POSSIE-DE + POSSIE-RECOPIE 4-20MA + POSSIE-FDC
mm	inch	Ref.	Ref.	Ref.	Ref.
40-80	1"1/2-3"	300180084	300180085	300200317	300200327
		300180086	300180087	300200326	300200332
100	4"	300180306	300180307	300200318	300200328
		300180308	300180309	300200322	300200333
125-150	5"-6"	300180310	300180311	300200319	300200329
		300180312	300180313	300200323	300200334
200-250	8"-10"	300180314	300180315	300200320	300200330
		300180316	300180317	300200324	300200335
300	12"	300180318	300180319	300200321	300200331
		300180320	300180321	300200325	300200336

RECOPIE : Information du positionnement sur un tableau / Information about positioning information on a board  
FDC : Fin de course qui permet d'indiquer visuellement la position / Limit switch visually indicates the position

Zone ATEX / ATEX zone : II 2G Ex ia IIC T6/T4 Gb  
II 3G Ex ic IIC T6/T4 Gc

Autres types de protections sur demande / Other protection zone on request

**KIT CONTACT FIN DE COURSE XCKM I LIMIT SWITCH KIT**

**Mécanique | Mechanical**

**Kit contact fin de course mécanique XCKM115**

Mechanical limit switch XCKM115



**Composé de :**

- 1 contact fin de course électromécanique
- 1 connecteur
- 1 plaque support inox, vis
- Index de position inox

**Comprised of:**

- 1 electro-mechanical limit switch
- 1 connector
- 1 Stainless steel support plate, screws
- Stainless steel position indicator



DN		1 Contact Ouverture / Open	1 Contact Fermeture / Closed	2 Contacts
mm	inch	Ref.	Ref.	Ref.
50	2"	300180106		300180109
65	2"1/2			
80	3"			
100	4"	300180107		300180110
125	5"		300180108	
150	6"			
200	8"			
250	10"	300180108		300180111
300	12"			
350-800	12"-48"	300200298	300200298	300110013
900-1200	36"-40"	300230062	300230062	300230063

**KIT SUPPORT POUR CFC I MECHANICAL LIMIT SWITCH SUPPORT**

**Mécanique | Mechanical**

**Plaque support inox + visserie pour contact fin de course mécanique XCKM**

Stainless steel SUP. + screw kit for mechanical limit switch



**Composé de :**

- Plaque support inox pour XCKM + vis
- Index de position inox

**Comprised of:**

- Support plate for limit switches XCKM + screws
- Stainless steel position index

DN		1 Contact Ouverture / Open	1 Contact Fermeture / Closed	2 Contacts
mm	inch	Ref.	Ref.	Ref.
50	2"	300110042	300110041	300110040
65-150	2"1/2-6"	300110045	300110044	300110043
200-300	8"-10"	300110048	300110047	300110046

**CONTACT FIN DE COURSE Ø12MM I LIMIT SWITCH Ø12MM**

**Inductif | Inductive**

**Kit contact fin de course inductif Ø12**

Inductive sensor Ø12



**Composé de :**

- 1 détecteur inductif télémeccanique M12 XS612B1PAM12
- 1 connecteur (XZCP1241L2) + 2m de fil
- 1 plaque support inox M12 - M18, vis
- Index de position inox

**Comprised of:**

- 1 contact XS612B1PAM12
- 1 connector XZCP1241L2 + 2m of cable
- 1 Stainless steel support plate, screws
- Stainless steel position index

DN		1 Contact Ouverture / Open	1 Contact Fermeture / Closed	2 Contacts
mm	inch	Ref.	Ref.	Ref.
50	2"			
65	2"1/2			
80	3"			
100	4"	300180102		300180104
125	5"		300180095	
150	6"			
200-300	8"	300180095		300180097
350-800	14"-32"	300230064	300230064	300230066
900-1200	36"-48"	300230065	300230065	300230067

**CONTACT FIN DE COURSE Ø18MM I LIMIT SWITCH Ø18MM**

**Inductif | Inductive**

**Kit contact fin de course inductif Ø18**

Inductive sensor Ø18



**Composé de :**

- 1 détecteur inductif M18 (IGS204)
- 1 connecteur coudé Femelle + 2m de fil
- 1 plaque support inox + écrous
- Index de position inox

**Comprised of:**

- 1 inductive proximity switch (IGS204)
- 1 Female connector + 2m of cable
- 1 Stainless steel support plate + screws
- Stainless steel position index

DN		1 Contact Ouverture / Open	1 Contact Fermeture / Closed	2 Contacts
mm	inch	Ref.	Ref.	Ref.
50	2"			300190321
65	2"1/2			
80	3"	300180098		
100	4"		300180099	300180100
125	5"			
150	6"			
200-300	8"	300180099		300180101
350-800	14"-32"	300230068	300230068	300230070
900-1200	36"-48"	300230069	300230069	300230071

DÉTECTEURS INDUCTIFS ATEX | ATEX INDUCTIVE LIMIT SWITCH

Détecteur inductif M12 ATEX P+F  
Inductive detector M12 ATEX P+F

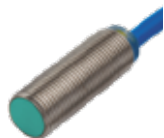

PEPPERL+FUCHS



Corps : Inox  
Diamètre : 12  
Portée : 2mm  
2 Fils NAMUR  
Câble PVC Lg 2m  
T° ambiante : -25°C / 100°C  
ATEX  
IP66 / IP67

Body: Stainless steel  
Diam.: 12  
Operating distance: 2mm  
2 cable NAMUR  
PVC cable Length 2m  
Ambiente temperature : -25°C / 100°C  
ATEX  
IP66 / IP67

Ref.
NCB2-12GM35-NO



ATEX 1G Ex ia IIC T6  
ATEX 2G Ex ia IIC T6  
ATEX 3G Ex ic IIC T6  
ATEX 1D Ex ia IIIC T135°C  
ATEX 2D Ex ib IIIC T135°C  
ATEX 3D Ex tc IIIC T80°C

KIT SUPPORT POUR DÉTECTEURS INDUCTIFS | SUPPORT FOR INDUCTIVE LIMIT SWITCH

Plaque support inox + visserie pour contact fin de course inductif M12-M18  
Stainless steel support. + screw kit for inductive M12-M18 limit switch



Composé de :  
- 1 plaque support Inox 304 + vis  
- Index de position inox

Comprised of:  
- 1 Stainless steel 304 support plate  
+ screws  
- Stainless steel position index

DN		1 Contact Ouverture / Open	1 Contact Fermeture / Closed	2 Contacts
mm	inch	Ref.	Ref.	Ref.
50-150	2"-6"	300130026	300130025	300130024
200-300	8"-12"	300130028	300130028	300130027
350-600	14"-24"	300190338	300190338	300130029

RAIL POUR DETECTEUR | SENSOR SUPPORT RAIL

Plaque support pour détecteur inductif M18 pour vanne à guillotine  
Support rail for sensor M18 for knife gate valve



Composé de :  
1 plaque support Inox 304  
Montage directement sur la vanne

Comprised of:  
1 Stainless steel 304 support plate  
Mounting directly on the valve

DN		Ref.	Nombre max de détecteur Max number of sensors
mm	inch		
50	2"	VGRAIL-0050	3
65	2"1/2	VGRAIL-0065	3
80	3"	VGRAIL-0080	3
100	4"	VGRAIL-0100	4
125	5"	VGRAIL-0125	4
150	6"	VGRAIL-0150	5
200	8"	VGRAIL-0200	6
250	10"	VGRAIL-0250	7
300	12"	VGRAIL-0300	8



**Permet le montage de plusieurs contacts inductifs et le positionnement sur la course.**  
Allows multiple inductive limit switches to be mounted at once and to be positioned along the stroke.

CAPOT DE PROTECTION | SECURITY PROTECTION

Capot de protection pour indicateur de position  
Security protection for position indicator



Matière : Inox 316  
Material: Stainless steel 316

DN		Ref.	DN		Ref.
mm	inch		mm	inch	
50	2"	VGPROTECIND-IN0050	250	10"	VGPROTECIND-IN0250
65	2"1/2	VGPROTECIND-IN0065	300	12"	VGPROTECIND-IN0300
80	3"	VGPROTECIND-IN0080	350	14"	VGPROTECIND-IN0350
100	4"	VGPROTECIND-IN0100	400	16"	VGPROTECIND-IN0400
125	5"	VGPROTECIND-IN0125	500	20"	VGPROTECIND-IN0500
150	6"	VGPROTECIND-IN0150	600	24"	VGPROTECIND-IN0600
200	8"	VGPROTECIND-IN0200			

DN supérieurs sur demande / Other DN on request

## PLAQUES SUPPORT INOX | SUPPORT PLATES

Inox | Stainless steel

Plaques support inox préformées et pré-perçées pour recevoir les contacts fin de course et les électrodistributeurs ASCO®  
Stainless steel pre-shaped and pre-drilled support plates for mounting ASCO® limit switches and solenoid valves



Prix pour 2 pièces  
 . Sécurise les vannes et protège les contacts fin de course en cas d'ambiance agressive  
 . Simplifie le montage d'accessoires du DN50 au 300.

Price for 2 pieces  
 . Secure the valves and protect the limit switches.  
 . Simplified accessory mounting from DN50 to 300.

DN		Inox 316
mm	inch	Ref.
50	2"	VGPLAQSUP316-IN0050
65	2"1/2	VGPLAQSUP316-IN0065
80	3"	VGPLAQSUP316-IN0080
100	4"	VGPLAQSUP316-IN0100
125	5"	VGPLAQSUP316-IN0125
150	6"	VGPLAQSUP316-IN0150
200	8"	VGPLAQSUP316-IN0200
250	10"	VGPLAQSUP316-IN0250
300	12"	VGPLAQSUP316-IN0300
350	14"	VGPLAQSUP316-IN0350
400	16"	VGPLAQSUP316-IN0400
450	18"	VGPLAQSUP316-IN0450
500	20"	VGPLAQSUP316-IN0500
600	24"	VGPLAQSUP316-IN0600

DN supérieurs sur demande / Other DN on request

**En cas d'ambiance agressive**

À monter sur les références VG6400 pour une vanne TOUT INOX !

**In case of aggressive environments.**

To add to VG6400 range for a fully Stainless steel valve!

## PLAQUES | PLATES

Plaques pré-perçées pour support inductif type M18\*  
Pre-drilled support plates for type M18\* inductive sensors

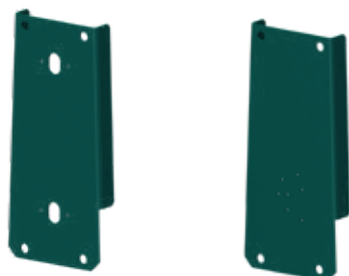

Kit comprenant :  
 - 1 plaque support acier carbone (type KL2)  
 - 2 plaques de réglage Inox 304 pour contact inductif M18 (ouv.-ferm)

Comprised of:  
 - 1 support Steel plate (KL2 type)  
 - 2 support Stainless steel 304 plate limit switches M18 (open-close)

Jusqu'au DN300 1 plaque + 2 plaques de réglage  
 A partir du DN350 = 1 seule plaque pré-perçée



DN		Ref.
mm	inch	
50	2"	300200299
65	2"1/2	300200300
80	3"	300200301
100	4"	300200302
125	5"	300200303
150	6"	300200304
200	8"	300200305
250	10"	300200306
300	12"	300200307
350	14"	300200308
400	16"	300200309
450	18"	300210111
500	20"	300200310
600	24"	300200311

DN supérieurs sur demande / Other DN on request  
 \* Type M12 sur demande / M12 type on request



**Idéal en papeterie**

Recommended for the paper industry



**Idéal en biogaz (avec le KIT PE spécifique page 134)**

Recommended for biogas industry (add kit biogas on page 140)



**L'index de position est protégé sous les plaques.**

The position indicator is protected under the support plates.



**CAPOT DE PROTECTION | SECURITY PROTECTION**

Capots de protection latéraux Inox 304 seuls

Stainless steel 304 side protections



Prix pour 2 pièces (la paire)  
Price for 2 pieces (the pair)

- Capots fournis en standard sur les vannes automatiques (vérins et moteurs) selon la directive machine ....
- Possible de les installer sur des vannes manuelles à tige montant UNIQUEMENT
- Side protections supplied as standard on automatic valves (cylinders and motors) according to the machine directive ....
- Can be installed on manual valves with rising stem ONLY

DN		Ref.	DN		Ref.
mm	inch		mm	inch	
50	2"	300180175	250	10"	300180182
65	2"1/2	300180176	300	12"	300180183
80	3"	300180177	350	14"	300180184
100	4"	300180178	400	16"	300180185
125	5"	300180179	450	18"	300180186
150	6"	300180180	500	20"	300180187
200	8"	300180181	600	24"	300180188

DN supérieurs sur demande / Other DN on request



**Inox 316 sur demande**  
Stainless steel 316 on request

**CAPOTAGE DE PROTECTION I PROTECTION**

Capot de protection détecteur inductif pour vanne à guillotine

Inductive sensor protection kit for knife gate valves



- Composé de :
- Capots de protection droit/gauche/central Inox 304
  - Indicateur détection Inox 304
  - Rail pour Kit + vis
  - Support capteur M18

Réglable sur rail des contacts inductifs / Ouverture aisée pour contrôle, protège les contacts contre toutes projections (pâte à papier ...)

- Comprised of:
- Protection support detection right/left/face Stainless steel 304
  - Indicator Stainless steel 304
  - Rail for special detection kit + screws
  - Limit switch support M18

Adjustable on rail / Easy opening for inspection, protect limit switches from potential pulp projection

DN		Ref.
mm	inch	
50	2"	300110168
65	2"1/2	300110169
80	3"	300110170
100	4"	300110171
125	5"	300110172
150	6"	300110173
200	8"	300110174
250	10"	300110175
300	12"	300110176



**Idéal en industrie lourde (papèterie ...)**  
Ideal for heavy industries (paper plant, etc.)



Contact fin de course non compris.  
Limit switches not included.

**KIT SOUFFLAGE I FLUSHING HOLES**

Kit trous de soufflage sur vanne à guillotine VG4400/VG6400

Flushing hole kit for knife gate valve VG4400/VG6400



Prix à ajouter au prix de la VG (VG4400/VG6400)  
Disponible en version fonte ou Inox

Price to be added to price of knife gate valve (VG4400/6400)  
Available in Ductile iron or Stainless steel



**Les trous de soufflage permettent de limiter les accumulations dans les parties basses du corps, donc le coincement de la vanne. Option idéale pour la papèterie ou les mines.**

Flushing holes limit the accumulation of debris in hollow areas that could block the valve. An ideal option for the paper and mining industries.

DN		Fonte / Ductile Iron	Inox / Stainless steel
mm	inch	Ref.	Ref.
50	2"	VGKITSOUFFLAGE-0050	VGKITSOUFFLAGEI-0050
65	2"1/2	VGKITSOUFFLAGE-0065	VGKITSOUFFLAGEI-0065
80	3"	VGKITSOUFFLAGE-0080	VGKITSOUFFLAGEI-0080
100	4"	VGKITSOUFFLAGE-0100	VGKITSOUFFLAGEI-0100
125	5"	VGKITSOUFFLAGE-0125	VGKITSOUFFLAGEI-0125
150	6"	VGKITSOUFFLAGE-0150	VGKITSOUFFLAGEI-0150
200	8"	VGKITSOUFFLAGE-0200	VGKITSOUFFLAGEI-0200
250	10"	VGKITSOUFFLAGE-0250	VGKITSOUFFLAGEI-0250
300	12"	VGKITSOUFFLAGE-0300	VGKITSOUFFLAGEI-0300
350	14"	VGKITSOUFFLAGE-0350	VGKITSOUFFLAGEI-0350
400	16"	VGKITSOUFFLAGE-0400	VGKITSOUFFLAGEI-0400
500	18"	VGKITSOUFFLAGE-0500	VGKITSOUFFLAGEI-0500
600	20"	VGKITSOUFFLAGE-0600	VGKITSOUFFLAGEI-0600
800	24"	VGKITSOUFFLAGE-0800	VGKITSOUFFLAGEI-0800

DN supérieurs sur demande / Other DN on request



**Nous préconisons l'installation de système anti-retour pour protéger le système de soufflage. Nous contacter pour tout besoin.**  
We specify installing an anti-return system to protect the flushing system. Contact us.



**Déflecteur | Deflector**

- ✓ Protège le corps : évite la pénétration du produit dans les zones creuses.
- ✓ Permet la régulation du flux.
- ✓ Canalise le fluide au centre du passage.
- ✓ Protects the Body: prevents penetration of the product in hollow areas.
- ✓ Enables flow regulation.
- ✓ Channels the fluid to the center of the passage.



Notre gamme de déflecteurs TECOFI peut être montée sur nos modèles de vannes à guillotine unidirectionnelles:  
Our TECOFI's range deflectors can be mounted on all unidirectional knife gate valves :

VG3400 / VGA3430 / VG4400 / VGA4430 / VG6400 / VGA6430



Les déflecteurs TECOFI ne peuvent pas être utilisés sur notre gamme de vannes à guillotine sous silo  
TECOFI's deflectors cannot be used on our under silo knife gate valves

**DEFLECTEUR | DEFLECTOR**

**Circulaire | Conical**

Déflecteur circulaire Inox 316 pour vanne à guillotine

Stainless steel 316 conical deflector for knife gate valves



Fonction : Protège le corps

Function: Protects body



**Prévoir un joint entre le corps et le déflecteur pour l'étanchéité, voir page 315.**  
Use gasket between body and deflector for tightness, see on page 315.

DN		Ref.	DN		Ref.
mm	inch		mm	inch	
50	2"	VGDEFLECSTD-0050	400	16"	VGDEFLECSTD-0400
65	2"1/2	VGDEFLECSTD-0065	450	18"	VGDEFLECSTD-0450
80	3"	VGDEFLECSTD-0080	500	20"	VGDEFLECSTD-0500
100	4"	VGDEFLECSTD-0100	600	24"	VGDEFLECSTD-0600
125	5"	VGDEFLECSTD-0125	700	28"	VGDEFLECSTD-0700
150	6"	VGDEFLECSTD-0150	800	32"	VGDEFLECSTD-0800
200	8"	VGDEFLECSTD-0200	900	36"	VGDEFLECSTD-0900
250	10"	VGDEFLECSTD-0250	1000	40"	VGDEFLECSTD-1000
300	12"	VGDEFLECSTD-0300	1200	48"	VGDEFLECSTD-1200
350	14"	VGDEFLECSTD-0350			

**DEFLECTEUR | DEFLECTOR**

**Triangulaire | Triangular**

Déflecteur conique triangulaire Inox 316 pour vanne à guillotine

Stainless steel 316 triangular conical deflector for knife gate valves



Fonction : Protège le corps et permet la régulation du flux

Function: Protects body and allows flow regulation



**Prévoir un joint entre le corps et le déflecteur pour l'étanchéité, voir page 315.**  
Use gasket between body and deflector for tightness, see on page 315.

DN		Ref.	DN		Ref.
mm	inch		mm	inch	
50	2"	VGDEFLECTRI-0050	400	16"	VGDEFLECTRI-0400
65	2"1/2	VGDEFLECTRI-0065	450	18"	VGDEFLECTRI-0450
80	3"	VGDEFLECTRI-0080	500	20"	VGDEFLECTRI-0500
100	4"	VGDEFLECTRI-0100	600	24"	VGDEFLECTRI-0600
125	5"	VGDEFLECTRI-0125	700	28"	VGDEFLECTRI-0700
150	6"	VGDEFLECTRI-0150	800	32"	VGDEFLECTRI-0800
200	8"	VGDEFLECTRI-0200	900	36"	VGDEFLECTRI-0900
250	10"	VGDEFLECTRI-0250	1000	40"	VGDEFLECTRI-1000
300	12"	VGDEFLECTRI-0300	1200	48"	VGDEFLECTRI-1200
350	14"	VGDEFLECTRI-0350			

**DEFLECTEUR | DEFLECTOR**

**En "V" | "V"**

Déflecteur conique en "V" Inox 316 - 90° pour vanne à guillotine

Stainless steel 316 "V" 90° conical deflector for knife gate valves



Fonction : Protège le corps et permet la régulation du flux

Function: Protects body and allows flow regulation



**Prévoir un joint entre le corps et le déflecteur pour l'étanchéité, voir page 315.**  
Use gasket between body and deflector for tightness, see on page 315

DN		Ref.	DN		Ref.
mm	inch		mm	inch	
50	2"	VGDEFLECV90-0050	400	16"	VGDEFLECV90-0400
65	2"1/2	VGDEFLECV90-0065	450	18"	VGDEFLECV90-0450
80	3"	VGDEFLECV90-0080	500	20"	VGDEFLECV90-0500
100	4"	VGDEFLECV90-0100	600	24"	VGDEFLECV90-0600
125	5"	VGDEFLECV90-0125	700	28"	VGDEFLECV90-0700
150	6"	VGDEFLECV90-0150	800	32"	VGDEFLECV90-0800
200	8"	VGDEFLECV90-0200	900	36"	VGDEFLECV90-0900
250	10"	VGDEFLECV90-0250	1000	40"	VGDEFLECV90-1000
300	12"	VGDEFLECV90-0300	1200	48"	VGDEFLECV90-1200
350	14"	VGDEFLECV90-0350			



**Nos différents modèles de pelle en option :**

Nous préconisons un montage de pelle traitée sur les corps acier / acier inoxydable pour plus d'efficacité.

**Une résistance accrue face à l'abrasion et la corrosion****PELLE TRANCHANTE EN INOX 316L**

Usinée et polie pour une fermeture sans blocage.

**PELLE POLIE MIROIR (OPTION)**

Évite l'accroche des produits sur la pelle.

**PELLE DURCIE (OPTION)**

Traitement à cœur HARDOX® (traitement dur pour résister à l'abrasion, sable, cimenterie), traitement de surface ou acier Superduplex (idéal pour eau de mer), pour renforcer la dureté de la pelle (option). Rallonge la durée de vie du produit.

Résiste aux chocs (par exemple en sortie de pulpeur pour la papeterie).

Lutte contre la corrosion.

**Nuances de différentes matières disponibles, nous consulter pour des applications spéciales (corps, pelle Duplex, Superduplex ...).**

**Our different optional knife models:**

We recommend mounting a treated gate with a steel/stainless steel body for better efficiency.

**Enhanced resistance against abrasion and corrosion****STAINLESS STEEL CUTTING GATE / 316L**

Machined and polished for closure without blockage.

**MIRROR-POLISHED GATE (OPTION)**

Prevents products from sticking to the gate (option).

**HARDENED VG GATE (OPTION)**

HARDOX® core treatment (treatment to resist sand and cement abrasions), surface treatment or Superduplex steel (ideal for seawater), to reinforce the hardness of the gate (option). Lengthen the lifespan of the product.

Resistant to shocks (for example at the exit of pulpers in the paper industry).

Fights against corrosion.

**Different material grades available, consult us for special applications (body, Duplex gate, Superduplex ...).**

**PELLE INOX 316L | STAINLESS STEEL 316L GATE**

Pelle Inox 316L pour vanne à guillotine VG4400 / VG6400

Stainless steel 316L gate for knife gate valves



DN		Ref.	DN		Ref.
mm	inch		mm	inch	
50	2"	VGPELLE316-0050	400	16"	VGPELLE316-0400
65	2"1/2	VGPELLE316-0065	450	18"	VGPELLE316-0450
80	3"	VGPELLE316-0080	500	20"	VGPELLE316-0500
100	4"	VGPELLE316-0100	600	24"	VGPELLE316-0600
125	5"	VGPELLE316-0125	700	28"	VGPELLE316-0700
150	6"	VGPELLE316-0150	800	32"	VGPELLE316-0800
200	8"	VGPELLE316-0200	900	36"	VGPELLE316-0900
250	10"	VGPELLE316-0250	1000	40"	VGPELLE316-1000
300	12"	VGPELLE316-0300	1200	48"	VGPELLE316-1200
350	14"	VGPELLE316-0350			



**Avec un produit très collant, nous préconisons d'ajouter un racleur page 130 pour une pelle propre et sans remontées.**

**For use with very sticky products, we recommend adding a scraper on page 130 to maintain a clean gate without dirt.**



## RACLEUR | SCRAPER

## Racleur Inox 304 pour vanne à guillotine VG4400/VG6400

Scraper for knife gate valve Stainless steel 304 VG4400/VG6400



Matière : Inox 304

Installé au niveau du fouloir pour VG4400 / VG6400.

Material: Stainless steel 304

To be installed at packing gland level for VG4400 / VG6400.



**Autres nuances sur demande**  
Other materials on request



**Élimine les particules collées sur la pelle des deux côtés**  
Removes particles stuck to both sides of the gate

DN		Ref.
mm	inch	
50	2"	VGRACLEUR-0050
65	2 1/2"	VGRACLEUR-0065
80	3"	VGRACLEUR-0080
100	4"	VGRACLEUR-0100
125	5"	VGRACLEUR-0125
150	6"	VGRACLEUR-0150
200	8"	VGRACLEUR-0200
250	10"	VGRACLEUR-0250
300	12"	VGRACLEUR-0300
350	14"	VGRACLEUR-0350
400	16"	VGRACLEUR-0400
450	18"	VGRACLEUR-0450
500	20"	VGRACLEUR-0500
600	24"	VGRACLEUR-0600

DN supérieurs sur demande / Other DN on request  
Racleurs différents pour VGB / Different model scraper for VGB

## JOINT DE SIÈGE | SEAT GASKET

## Joint de siège pour vanne à guillotine standard VG4400/VG6400

Seat gasket for standard knife gate valve VG4400/VG6400



Prix indiqué pour le joint seul, sans montage

Price for gasket only without assembly

DN		Joint / Gasket EPDM T° maxi : 130°C	Joint / Gasket NBR T° maxi : 80°C	Joint / Gasket FPM T° maxi : 170°C	Bague / Ring PTFE T° maxi : 170°C (étanchéité relative / Relative tightness)
mm	inch	Ref.	Ref.	Ref.	Ref.
50	2"	VGJOINTMOU-EP0050	VGJOINTMOU-NI0050	VGJOINTMOU-VI0050	VGJOINTMOU-PTF0050
65	2 1/2"	VGJOINTMOU-EP0065	VGJOINTMOU-NI0065	VGJOINTMOU-VI0065	VGJOINTMOU-PTF0065
80	3"	VGJOINTMOU-EP0080	VGJOINTMOU-NI0080	VGJOINTMOU-VI0080	VGJOINTMOU-PTF0080
100	4"	VGJOINTMOU-EP0100	VGJOINTMOU-NI0100	VGJOINTMOU-VI0100	VGJOINTMOU-PTF0100
125	5"	VGJOINTMOU-EP0125	VGJOINTMOU-NI0125	VGJOINTMOU-VI0125	VGJOINTMOU-PTF0125
150	6"	VGJOINTMOU-EP0150	VGJOINTMOU-NI0150	VGJOINTMOU-VI0150	VGJOINTMOU-PTF0150
200	8"	VGJOINTMOU-EP0200	VGJOINTMOU-NI0200	VGJOINTMOU-VI0200	VGJOINTMOU-PTF0200
250	10"	VGJOINTMOU-EP0250	VGJOINTMOU-NI0250	VGJOINTMOU-VI0250	VGJOINTMOU-PTF0250
300	12"	VGJOINTMOU-EP0300	VGJOINTMOU-NI0300	VGJOINTMOU-VI0300	VGJOINTMOU-PTF0300
350	14"	VGJOINTMOU-EP0350	VGJOINTMOU-NI0350	VGJOINTMOU-VI0350	VGJOINTMOU-PTF0350
400	16"	VGJOINTMOU-EP0400	VGJOINTMOU-NI0400	VGJOINTMOU-VI0400	VGJOINTMOU-PTF0400
450	18"	VGJOINTMOU-EP0450	VGJOINTMOU-NI0450	VGJOINTMOU-VI0450	VGJOINTMOU-PTF0450
500	20"	VGJOINTMOU-EP0500	VGJOINTMOU-NI0500	VGJOINTMOU-VI0500	VGJOINTMOU-PTF0500
600	24"	VGJOINTMOU-EP0600	VGJOINTMOU-NI0600	VGJOINTMOU-VI0600	VGJOINTMOU-PTF0600
700	28"	300230037	300230042	300230047	300230052
800	32"	300230038	300230043	300230048	300230053
900	36"	300230039	300230044	300230049	300230054
1000	40"	300230040	300230045	300230050	300230055
1200	48"	300230041	300230046	300230051	300230056



**Pour optimiser votre changement de joint de siège, pensez également à la frette Inox**  
To optimize seat gasket replacement, think of also adding a Stainless steel support ring



**FRETTE INOX | STAINLESS STEEL SUPPORT RING**

Frette Inox 316 pour joint de siège pour vanne à guillotine standard VG4400/VG6400  
Stainless steel 316 support ring for seat gasket for standard knife gate valves



**Pour optimiser votre changement de joint, il est conseillé de changer également la frette. To optimize your seat gasket replacement, change also the support ring.**



Chanfrein côté intérieur  
Beveled inside



DN		Ref.	DN		Ref.
mm	inch		mm	inch	
50	2"	VG FRETTE-0050	400	16"	VG FRETTE-0400
65	2"1/2	VG FRETTE-0065	450	18"	VG FRETTE-0450
80	3"	VG FRETTE-0080	500	20"	VG FRETTE-0500
100	4"	VG FRETTE-0100	600	24"	VG FRETTE-0600
125	5"	VG FRETTE-0125	700	28"	VG FRETTE-0700
150	6"	VG FRETTE-0150	800	32"	VG FRETTE-0800
200	8"	VG FRETTE-0200	900	36"	VG FRETTE-0900
250	10"	VG FRETTE-0250	1000	40"	VG FRETTE-1000
300	12"	VG FRETTE-0300	1200	48"	VG FRETTE-1200
350	14"	VG FRETTE-0350			

**JOINT DE SIÈGE POUR VGB | VGB SEAT GASKET**

Joint de siège pour vanne à guillotine bidirectionnelle VGB  
Seat gasket for bidirectional knife gate valve



Prix indiqué pour le joint seul, sans montage

Price for gasket only without assembly

DN		Ref.	Ref.
mm	inch		
50	2"	VGBNJOINT-EP0050	VGBNJOINT-NI0050
65	2"1/2	VGBNJOINT-EP0065	VGBNJOINT-NI0065
80	3"	VGBNJOINT-EP0080	VGBNJOINT-NI0080
100	4"	VGBNJOINT-EP0100	VGBNJOINT-NI0100
125	5"	VGBNJOINT-EP0125	VGBNJOINT-NI0125
150	6"	VGBNJOINT-EP0150	VGBNJOINT-NI0150
200	8"	VGBNJOINT-EP0200	VGBNJOINT-NI0200
250	10"	VGBNJOINT-EP0250	VGBNJOINT-NI0250
300	12"	VGBNJOINT-EP0300	VGBNJOINT-NI0300
350	14"	VGBNJOINT-EP0350	VGBNJOINT-NI0350
400	16"	VGBNJOINT-EP0400	VGBNJOINT-NI0400

DN supérieurs sur demande / Other DN on request

**VG FOULOIR FONTE | CAST IRON PACKING**

Fouloir de presse étoupe fonte ductile  
Ductile Iron packing gland



Matière : Fonte GS GGG40

Material: Ductile Iron GGG40

**Fonte ductile | Ductile Iron**

DN		Ref.	DN		Ref.
mm	inch		mm	inch	
50	2"	VGFOULOIRFONTE-0050	400	16"	VGFOULOIRFONTE-0400
65	2"1/2	VGFOULOIRFONTE-0065	450	18"	VGFOULOIRFONTE-0450
80	3"	VGFOULOIRFONTE-0080	500	20"	VGFOULOIRFONTE-0500
100	4"	VGFOULOIRFONTE-0100	600	24"	VGFOULOIRFONTE-0600
125	5"	VGFOULOIRFONTE-0125	700	28"	VGFOULOIRFONTE-0700
150	6"	VGFOULOIRFONTE-0150	800	32"	VGFOULOIRFONTE-0800
200	8"	VGFOULOIRFONTE-0200	900	36"	VGFOULOIRFONTE-0900
250	10"	VGFOULOIRFONTE-0250	1000	40"	VGFOULOIRFONTE-1000
300	12"	VGFOULOIRFONTE-0300	1200	48"	VGFOULOIRFONTE-1200
350	14"	VGFOULOIRFONTE-0350			

**VG FOULOIR INOX I SS PACKING GLAND**

**Inox 316 I Stainless steel 316**

Fouloir de presse étoupe Inox 316  
Stainless steel 316 packing gland



Matière : Inox 316

Material: Stainless steel 316

DN		Ref.	DN		Ref.
mm	inch		mm	inch	
50	2"	VGFOULOIRINOX-0050	400	16"	VGFOULOIRINOX-0400
65	2"1/2	VGFOULOIRINOX-0065	450	18"	VGFOULOIRINOX-0450
80	3"	VGFOULOIRINOX-0080	500	20"	VGFOULOIRINOX-0500
100	4"	VGFOULOIRINOX-0100	600	24"	VGFOULOIRINOX-0600
125	5"	VGFOULOIRINOX-0125			
150	6"	VGFOULOIRINOX-0150			
200	8"	VGFOULOIRINOX-0200			
250	10"	VGFOULOIRINOX-0250			
300	12"	VGFOULOIRINOX-0300			
350	14"	VGFOULOIRINOX-0350			

**KIT PRESSE ETOUPE I PACKING KIT**

Kit de rechange presse étoupe VG4400 I VG6400  
Kit for packing gland for VG4400 I VG6400



DN		Standard VG4400 - VGKITPE-F	Standard VG6400 - VGKITPE-I
mm	inch	Ref.	Ref.
		2 tresses PTFE - 1 torique NBR 2 PTFE packing - 1 NBR O-ring T° -10°C/+80°C	2 tresses PTFE - 1 torique EPDM 2 PTFE packing - 1 EPDM O-ring T° -10°C/+130°C
50	2"	VGKITPE-F0050	VGKITPE-I0050
65	2"1/2	VGKITPE-F0065	VGKITPE-I0065
80	3"	VGKITPE-F0080	VGKITPE-I0080
100	4"	VGKITPE-F0100	VGKITPE-I0100
125	5"	VGKITPE-F0125	VGKITPE-I0125
150	6"	VGKITPE-F0150	VGKITPE-I0150
200	8"	VGKITPE-F0200	VGKITPE-I0200
250	10"	VGKITPE-F0250	VGKITPE-I0250
300	12"	VGKITPE-F0300	VGKITPE-I0300
350	14"	VGKITPE-F0350	VGKITPE-I0350
400	16"	VGKITPE-F0400	VGKITPE-I0400
450	18"	VGKITPE-F0450	VGKITPE-I0450
500	20"	VGKITPE-F0500	VGKITPE-I0500
600	24"	VGKITPE-F0600	VGKITPE-I0600
700	28"	VGKITPE-F0700	-
800	32"	VGKITPE-F0800	-
900	36"	VGKITPE-F0900	-
1000	40"	VGKITPE-F1000	-
1200	48"	VGKITPE-F1200	-



**KIT PRESSE ETOUPE HEPHAISTOS | HEPHAISTOS PACKING KIT**

Kit presse étoupe avec tresse Héphaïstos - Haute température

Kit of Hephaisstos packing - High temperature



3 tresses héphaïstos (+ 825°C)

Attention T°C relative au corps de la vanne  
**VG4400 Fonte**

Pression de service maxi:  
DN50-450 : 5,5 bar  
DN500-600 : 4 bar  
DN700-1200 : 2 bar  
Température de service maxi : 0°C / +350°C

**VG6400 Inox**

Pression de service maxi:  
DN50-450 : 5,6 bar  
DN500-600 : 4 bar  
Température de service maxi : 0°C / +600°C

3 hephaistos packing (+ 825°C)

Caution T°C relative to the valve body

**VG4400 Ductile iron**

Max working pressure:  
DN50-450 : 5,5 bar  
DN500-600 : 4 bar  
DN700-1200 : 2 bar  
Max working temperature : 0°C / +350°C

**VG6400 Stainless steel**

Max working pressure:  
DN50-450 : 5,6 bar  
DN500-600 : 4 bar  
Max working temperature : 0°C / +600°C

DN		Ref.	DN		Ref.
mm	inch		mm	inch	
50	2"	300110338	500	20"	300110350
65	2"1/2	300110339	600	24"	300110351
80	3"	300110340	700*	28"	300210037
100	4"	300110341	800*	32"	300210038
125	5"	300110342	900*	36"	300210039
150	6"	300110343	1000*	40"	300210040
200	8"	300110344	1200*	48"	300210041
250	10"	300110345			
300	12"	300110346			
350	14"	300110347			
400	16"	300110348			
450	18"	300110349			

A partir du DN600 kits valables pour VG4400 uniquement  
From DN600 kits valid for VG4400 only

**KIT PRESSE ETOUPE ACS | ACS PACKING KIT**

ACS

Kit presse étoupe avec tresse alimentaire ACS

Kit for food-grade packing gland ACS



2 tresses alimentaires ACS  
1 joint de siège EPDM ACS  
Température de service : -10°C/+ 80°C

2 ACS food-grade packing glands  
1 EPDM ACS seal  
Working temperature: -10°C/+ 80°C

DN		Ref.
mm	inch	
50	2"	300200244
65	2"1/2	300200245
80	3"	300200246
100	4"	300200247
125	5"	300200248
150	6"	300200249
200	8"	300200250
250	10"	300200251
300	12"	300200252
350	14"	300200253
400	16"	300200254
450	18"	300200255
500	20"	300200256
600	24"	300200257



ACS pour Eau Potable  
ACS certification for Drinking Water



ACS

**TRESSE AVEC JOINT FPM | FPM PACKING KIT**

Kit presse étoupe avec joint FPM pour VG4400 / VG6400  
Kit of FPM packing for VG4400 / VG6400



2 tresses PTFE + 1 torique FPM

2 PTFE packing + 1 FPM O-ring

DN		Ref.	DN		Ref.
mm	inch		mm	inch	
50	2"	300110394	400	16"	300110404
65	2"1/2	300110395	450	18"	300110405
80	3"	300110396	500	20"	300110406
100	4"	300110397	600	24"	300110407
125	5"	300110398	700	28"	300210032
150	6"	300110399	800	32"	300210033
200	8"	300110400	900	36"	300210034
250	10"	300110401	1000	40"	300210035
300	12"	300110402	1200	48"	300210036
350	14"	300110403			

**KIT TRESSE POUR VGB | PACKING FOR VGB**

Kit presse étoupe pour VGB  
Kit of packing for VGB



3 tresses PTFE

3 PTFE packing

DN		Ref. VGB
mm	inch	
50	2"	300200005
65	2"1/2	300200006
80	3"	300200007
100	4"	300200008
125	5"	300200009
150	6"	300200010
200	8"	300200011
250	10"	300200012
300	12"	300200013
350	14"	300200014
400	16"	300200015

**TRESSE POUR APPLICATIONS BIOGAZ POUR VGB | PACKING FOR BIOGAS APPLICATIONS FOR VGB**

Kit presse étoupe pour application biogaz pour VGB  
Kit of packing for biogas applications for VGB



**Spécial biogaz**  
For biogas applications



Kit de 3 tresses renforcées en fibres Aramide

Packing reinforced with Aramide fibers

Application BIOGAZ pour une performance maximale :

- excellente tenue mécanique
- bonne résistance sur fluides abrasifs
- auto lubrifiante
- tresse exempte de silicone

Biogas application for maximum performance:

- excellent mechanical strength
- good resistance to abrasive fluids
- self-lubricating
- packing silicone-free



DN		Ref. VGB BIOGAZ
mm	inch	
50	2"	300180293
65	2"1/2	300180294
80	3"	300180295
100	4"	300180296
125	5"	300180297
150	6"	300180298
200	8"	300180299
250	10"	300180300
300	12"	300180301
350	14"	300190312
400	16"	300190313



**Tresse inférieure renforcée avec effet racleur**  
Lower packing doubles as a scraper



# KIT COLONNETTE DROITE POUR VG\*

PEDESTAL FLOOR MOUNTED KIT FOR KNIFE GATE VALVE\*

## À VOLANT | WITH HANDWHEEL

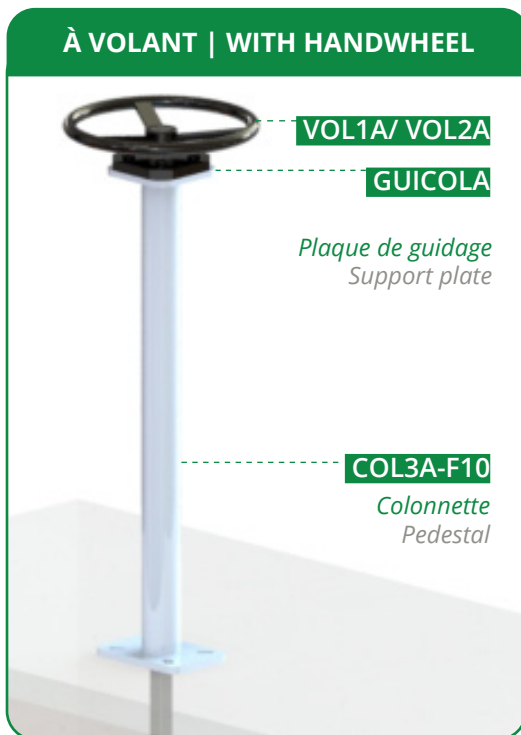

## PAR CARRÉ DE MANOEUVRE | SQUARE TOP

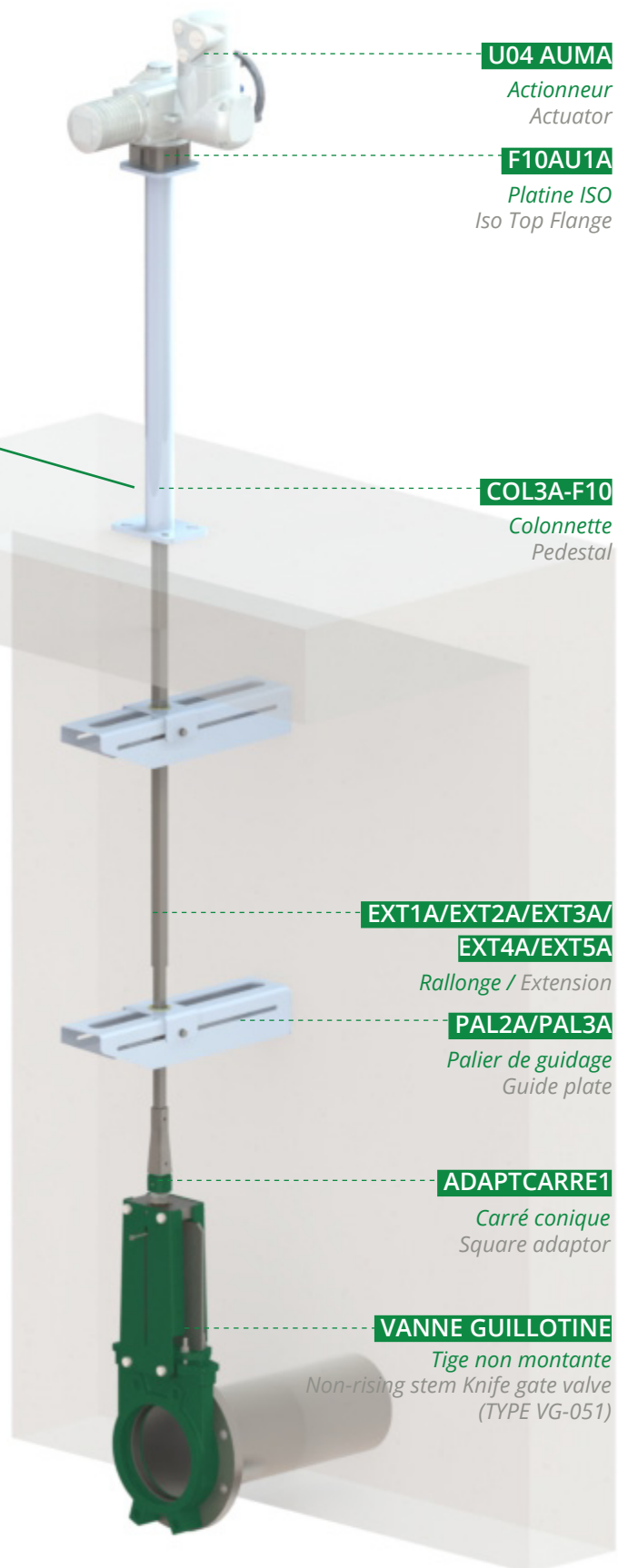

### Kit à utiliser avec les vannes à guillotine

**VG4400-051** - Page 97  
**VG6400-051** - Page 106

### Kit to use with knife gate valve

**VG4400-051** - Page 97  
**VG6400-051** - Page 106

Représentation à titre indicatif (contre-brides et tirants non représentés, ils sont obligatoires dans toutes installations).  
Representation for reference only (counter flanges and tie rods not shown are required in all installations).

# KIT COLONNETTE MURALE POUR VG\*

PEDESTAL WALL MOUNTED KIT FOR KNIFE GATE VALVE\*

À VOLANT | WITH HANDWHEEL



**Kit à utiliser avec les vannes à guillotine**  
**VG4400-051** - Page 97  
**VG6400-051** - Page 106

**Kit to use with knife gate valve**  
**VG4400-051** - Page 97  
**VG6400-051** - Page 106



La distance entre le mur et les colonnettes murales n'est pas réglable, prévoir un déport avec le mur ou un système pour plaquer la colonnette à la bonne distance.  
 The distance between the wall and the wall column is not adjustable, provide an offset with the wall or a system to place the column at the right distance.

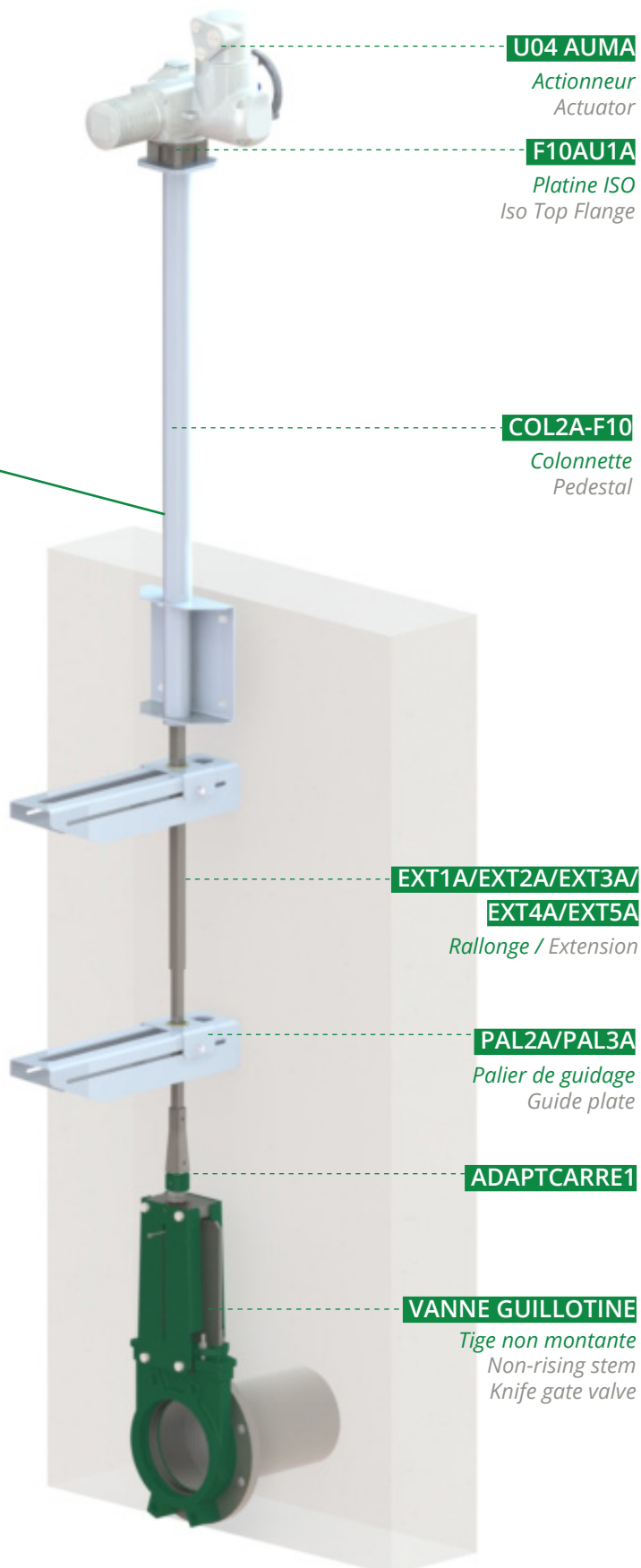

Représentation à titre indicatif (contre-bridés et tirants non représentés, ils sont obligatoires dans toutes installations).  
 Representation for reference only (counter flanges and tie rods not shown are required in all installations).





## TRINGLERIES POUR MONTAGE SUR COLONNETTE LINKAGE FOR PEDESTAL MOUNTING

### CLE DE FONTAINIER I HYDRANT KEY

Clé de fontainier  
Hydrant key

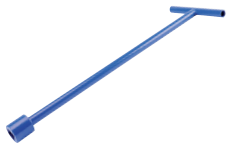

Matière : Acier  
Carré : 30mm

Material: Steel  
Square: 30mm

L	Ref.
1M	VOCLEWRENCH-1.0ML



**Avec embout universel pour carré de manœuvre**  
With universal end for operating square

### CARRE CONIQUE I SQUARE ADAPTOR

Pour adaptation de carré conique à rallonge EXT  
Square 30x30 adaptor for EXT extension



Matière : Inox 304

Material: Stainless steel 304

Ref.
ADAPTCARRE1

### RALLONGE I EXTENSION

Rallonge télescopique  
Telescopic extension



Matière : 316L

Material: 316L



Ajouter la dimension B du passeport technique VG3400-051 pour la distance du centre de la tuyauterie à la manœuvre.

Add the dimension B from the VG3400-051 technical sheet for the distance of the pipe axis to the actuator

Dimension (mm)	Ref.
800 - 1100	EXT1A
1100 - 1750	EXT2A
1750 - 3000	EXT3A
3000 - 5500	EXT4A
4000-8000	EXT5A

### CARRE I SQUARE

Carré de manœuvre 30x30  
Conical square 30x30



Matière : Inox 304

Material: Stainless steel 304

Ref.
CARRE1-2A

### PALIER DE GUIDAGE I GUIDE PLATE

Palier de guidage fixe pour rallonge télescopique  
Guide plate bearing for telescopic extension EXT

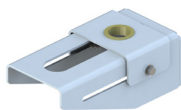

Matière : Inox 316L

Material: Stainless steel 316L

Dimension (mm)	Ref.
70-200	PAL2A
70-500	PAL3A



**Mettre obligatoirement un palier tous les deux mètres + un autre avant le passage dans la colonnette.**  
Place one guide every two meters of the extension + one guide plate just before the pedestal floor.





**COLONNETTES | PEDESTAL**

Colonne pour vanne murale  
Pedestal for penstock

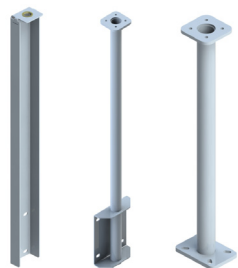

- COL1A : pour commande par volant et fixation murale
- COL2A-F10 : pour commande motorisée (F10) et fixation murale
- COL3A-F10 : pour commande motorisée (F10) et fixation au sol

Matière : Inox 304  
Hauteur : 900mm

Pedestal wall mounted for handwheel  
Pedestal wall mounted for Auma actuator (F10)  
Pedestal floor mounted for Auma actuator (F10)

Material: Stainless steel 304  
Height: 900mm

Ref.
COL1A
COL2A-F10
COL3A-F10

1 2 3

**PLAQUE DE GUIDAGE | SUPPORT PLATE**

Guidage pour volant adaptable sur colonne COL2A-F10 / COL3A-F10 (uniquement)  
Support plate for handwheel adaptable for COL2A-F10 / COL3A-F10

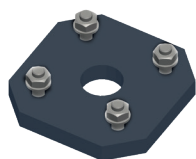

Matière : POM

Material: POM

Ref.
GUICOLA

**VOLANT | HANDWHEEL**

Volant  
Handwheel



Matière : Acier revêtu Epoxy  
Diamètre : 300mm

Material: Epoxy-coated carbon steel  
Diameter: 300mm

DN	Ref.
50-300	VOL1A
350-400	VOL2A

**PLATINE POUR MOTEUR | MOTOR PLATE**

Platine pour moteur Auma  
Support plate for Auma actuator

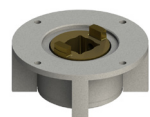

Matière : Acier  
Platine : ISO5210  
Pour montage sur extension «EXT»

Material: Carbon steel  
Top mounted flange: ISO5210  
For telescopic extension mounting «EXT»

DN	Ref.	
	mm	inch
50-400	2" - 16"	F10AU1A

DN supérieurs nous consulter  
Other DN on request

**U04 - MOTEUR VG - COLONNETTE MURALE | U04 AUMA ACTUATOR FOR PEDESTAL MOUNTING**

Motorisation Auma 3 phases 400V/50Hz On/Off  
3-phase Auma actuator 400V/50Hz On/Off



Moteur équipé de :  
- 2 contacts fin de course  
- 1 résistance de chauffe  
- 2 limiteurs de couple  
Commande manuelle de secours  
Indicateur visuel de position  
Protection IP68

Actuator equipped:  
- 2 limit switches  
- 1 heat resistor  
- 2 torque limiters switches  
Emergency handwheel  
Visual position indicator  
IP68 protection

DN	Ref.	
	mm	inch
50-100	2" - 4"	SA07.2-U04B1TOR63
125-200 300	5" - 10"	SA07.6-U04B1TOR63
250-350-400	12" - 16"	SA10.2-U04B1TOR63

DN supérieurs sur demande / Other DN on request  
Moteur modèle platine F10 / Actuator plate model F10





VANNES  
À GUILLOTINE  
**TECOFI**<sup>®</sup>  
KNIFE GATE  
VALVES



# VANNE MURALE

## PENSTOCK VALVE

### CARACTÉRISTIQUES

- Utilisable pour installations d'entrée et de sortie de bassin
- Adapté pour le sectionnement
- Etanchéité 4 côtés
- Faible couple
- Joint entièrement extrudé

Dimensions : 200x200 jusqu'à 1000x1000 en stock

Autres constructions et dimensions sur demande

### CHARACTERISTICS

- Usable for installation at inlets and outlets of chambers and basins
- Suitable for ON/OFF purposes
- Watertight on 4 sides
- Low torque
- Extruded seal

Dimensions: 200x200 up to 1000x1000 available

Other constructions and dimensions on request



Grand diamètre  
Large diameter



Tige non montante  
Non-rising stem



Vanne de déverse  
Spillway penstock



Traitement d'eau, rejet fluvial, irrigation, barrage  
Water treatment, river discharges, irrigation, dam

### PRODUIT ASSOCIÉ | TO COMPLETE

Retrouvez nos clapets d'extrémité page 173  
Find our terminal check valves on page 173



Nous fournissons les chevilles chimiques utiles pour le montage. Installation et mise en œuvre aisées !  
We supply chemical anchors useful for assembly. An all-inclusive and easy installation!



### VGM6205A-00 | VGM6206A-00

Vanne murale inox  
Penstock in Stainless steel



Corps : voir tableau  
Pelle : Inox 304 à 316L  
Joint : EPDM  
Etanchéité : 4 côtés bidirectionnel  
Pression : 6 mCE  
Tige non montante en inox 304 ou 316 L selon le modèle choisi (voir tableau)

Autres dimensions sur demande

Body: see table  
Gate: Stainless steel 304 to 316L  
Joint: EPDM  
Tightness: 4 sides bidirectional  
Pressure: 6 WC  
Non-rising stem in 304 or 316L  
Stainless steel according on the chosen model (see table)  
Other sizes on request

Dim.	Inox 304 Stainless steel 304	Inox 316L Stainless steel 316L
	Ref.	Ref.
200x200	VGM6205A-00EP0200	VGM6206A-00EP0200
300x300	VGM6205A-00EP0300	VGM6206A-00EP0300
400x400	VGM6205A-00EP0400	VGM6206A-00EP0400
500x500	VGM6205A-00EP0500	VGM6206A-00EP0500
600x600	VGM6205A-00EP0600	VGM6206A-00EP0600
700x700	VGM6205A-00EP0700	VGM6206A-00EP0700
800x800	VGM6205A-00EP0800	VGM6206A-00EP0800
900x900	VGM6205A-00EP0900	VGM6206A-00EP0900
1000x1000	VGM6205A-00EP1000	VGM6206A-00EP1000





**MONTAGE SUR CADRE**  
**PENSTOCK - FRAME MOUNTED**

**Commande par carré de manœuvre**

*Square top on frame*

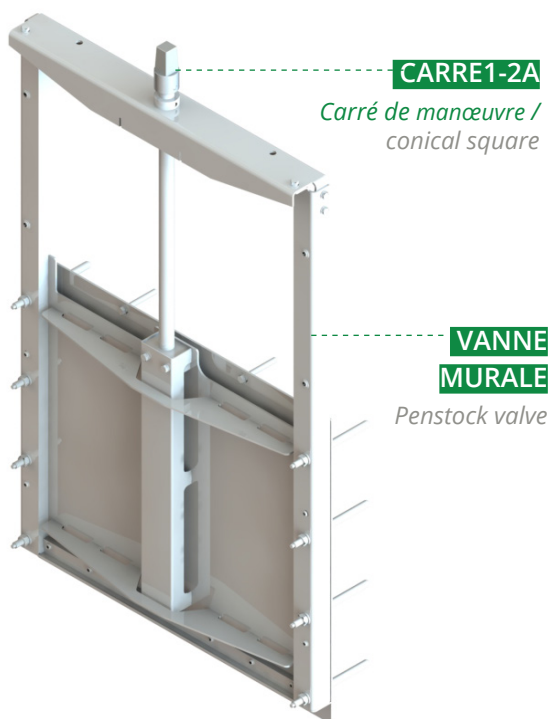

**Commande à moteur électrique**

*Electric actuator mounted*

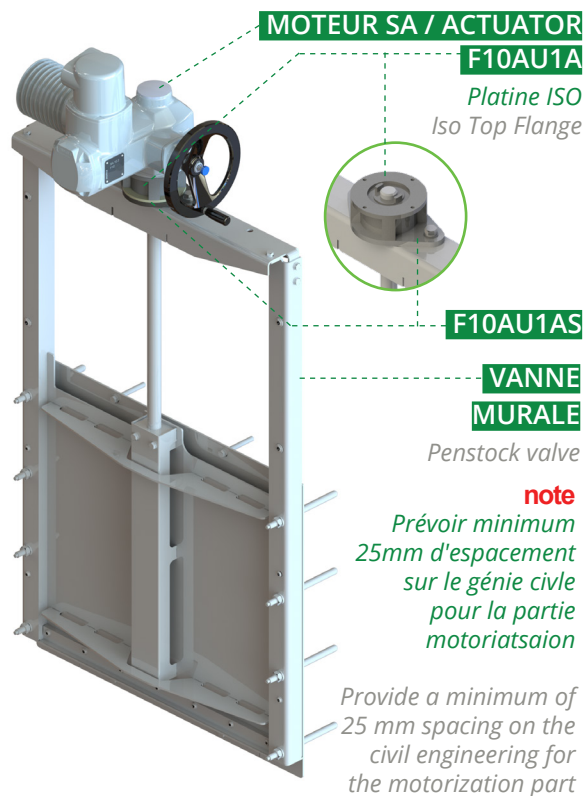

**Commande à volant**

*Manual actuation*

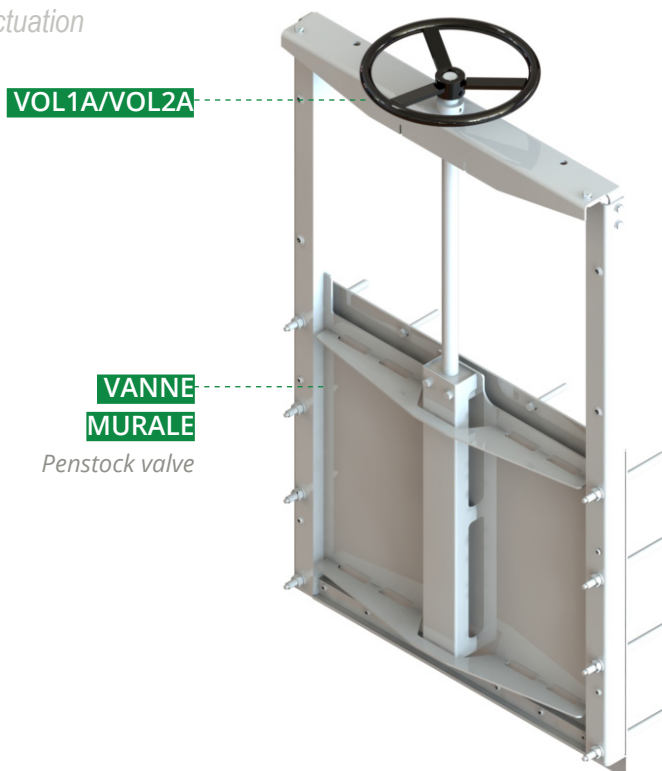



**MONTAGE SUR COLONNETTE MURALE**  
**PENSTOCK - FOR WALL MOUNTED PEDESTAL**

**Commande par carré de manœuvre à fleur**

*Square top on frame*

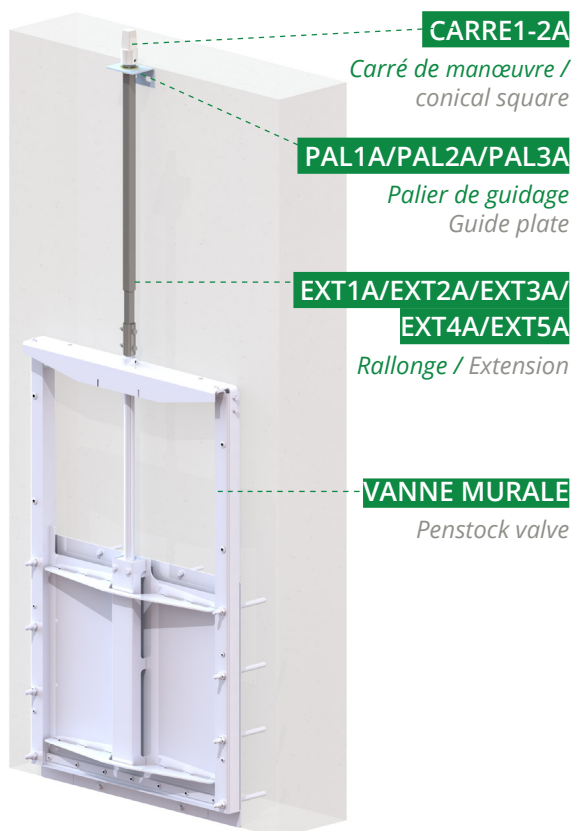

**Commande à moteur électrique**

*Electric actuator mounted*

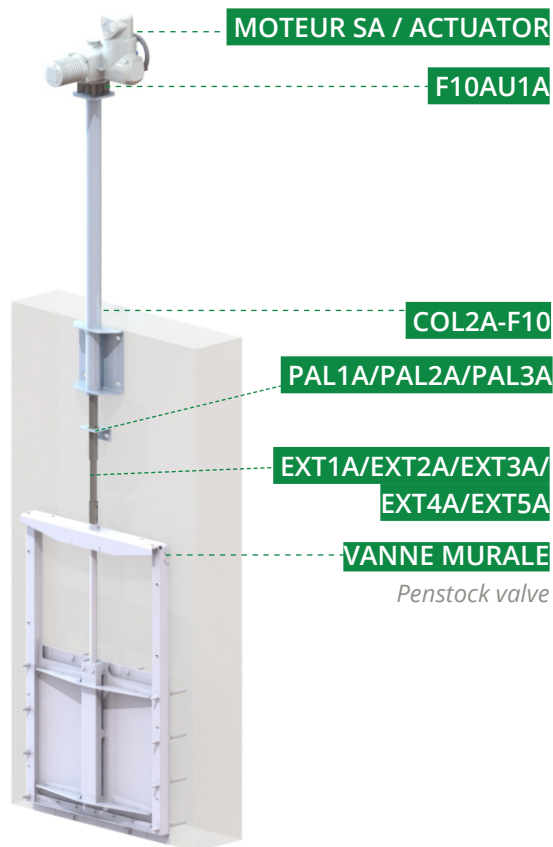

**Commande à volant**

*Manual actuation*

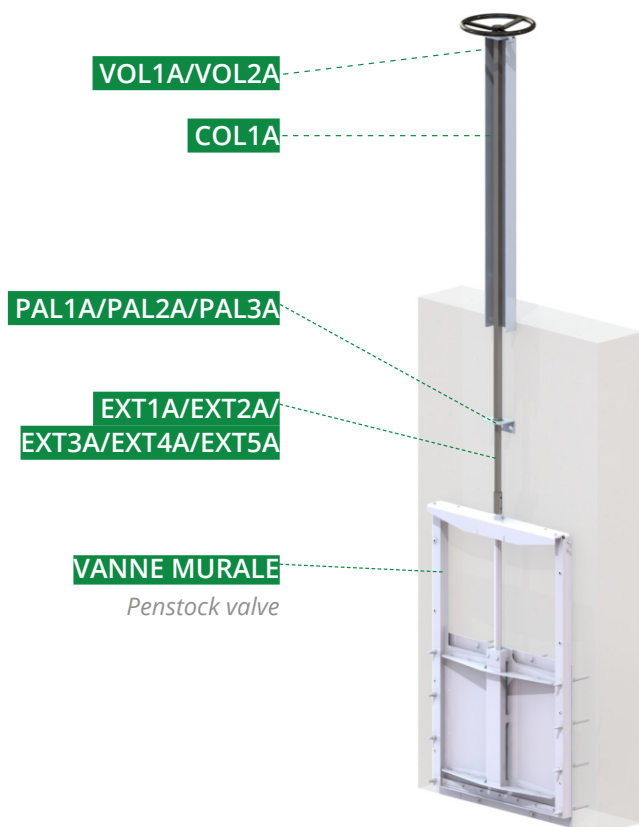



**MONTAGE SUR COLONNETTE DROITE**  
**PENSTOCK - FOR STRAIGHT PEDESTAL**

**Commande à moteur électrique sur colonnette**

*Electric actuator mounted*

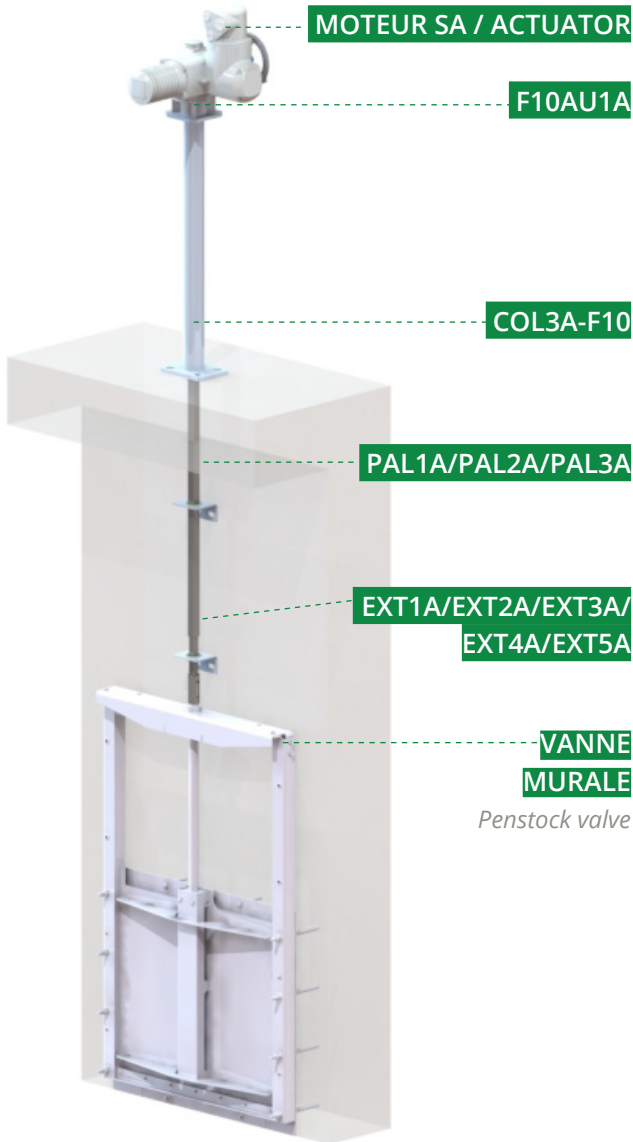

**Commande à volant sur colonnette**

*Manual actuation*

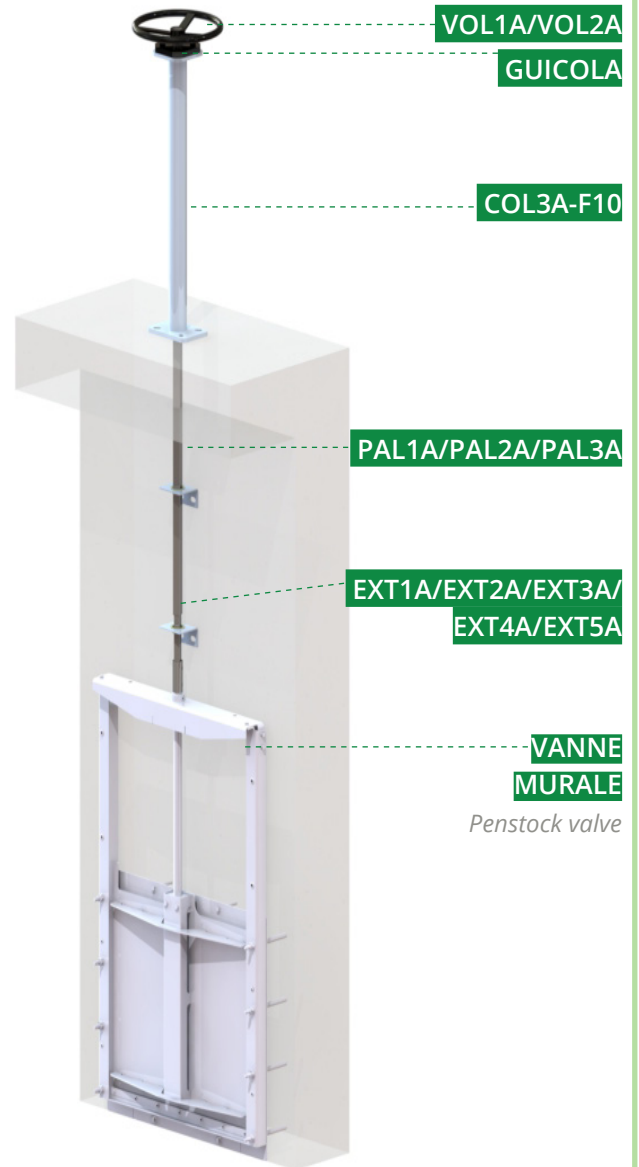



## TRINGLERIES POUR VANNE MURALE LINKAGE FOR PENSTOCK

### RALLONGE | EXTENSION

Rallonge télescopique se monte directement sur la tige de la vanne murale  
Telescopic spindle extension

Dimension (mm)	Ref.
800-1100	EXT1A
1100-1750	EXT2A
1750-3000	EXT3A
3000-5500	EXT4A
4000-8000	EXT5A



Matière : Inox 316L

Material: Stainless steel 316L



Ajouter la dimension H du passeport technique VGM6205-00 du bas de la vanne à la manoeuvre.

Add the dimension H from the VGM6205-00 technical sheet from the bottom of the vale to the actuator

### PALIER DE GUIDAGE | GUIDE PLATE

Palier de guidage fixe pour rallonge télescopique  
Guide plate for telescopic extension

Dimension (mm)	Ref.
70	PAL1A
70-200	PAL2A
70-500	PAL3A

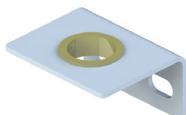

1

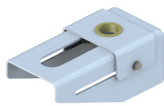

2

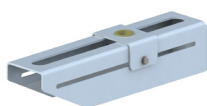

3



Matière : Inox 316L

Material: Stainless steel 316L



**Mettre obligatoirement un palier tous les deux mètres + un autre avant le passage dans la colonnette.**  
**Place one guide every two meters of the extension + one guide plate just before the pedestal floor**

### COLONNETTES | PEDESTAL

Colonette pour vanne murale  
Floor stand for penstock

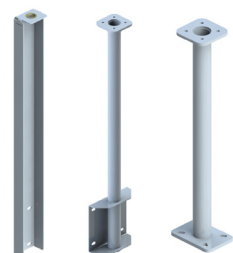

1

2

3



- COL1A : pour commande par volant et fixation murale
- COL2A-F10 : pour commande motorisée (F10) et fixation murale
- COL3A-F10 : pour commande motorisée (F10) et fixation au sol

Matière : Inox 304  
Hauteur: 900mm

Pedestal wall mounted for handwheel  
Pedestal wall mounted for Auma actuator (F10)  
Pedestal floor mounted for Auma actuator (F10)

Material: Stainless steel 304  
Height: 900mm

Ref.

COL1A

COL2A-F10

COL3A-F10





Type de manœuvre | Actuation type

CARRE | SQUARE

Carré de manœuvre 30x30  
Conical square 30x30



Matière : Inox 304

Material: Stainless steel 304

Ref.

CARRE1-2A

CLE DE FONTAINIER | HYDRANT KEY

Clé de fontainier  
Hydrant key

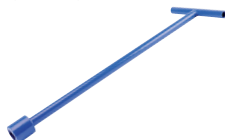

Matière : Acier  
Carré : 30mm

Material: Steel  
Square: 30mm

L

Ref.

1M

VOCLEVVRENCH-1.0ML



Avec embout universel pour carré de manoeuvre  
With universal end for operating square

PLAQUE DE GUIDAGE | SUPPORT PLATE

Guidage pour volant adaptable sur colonnette COL2A-F10 / COL3A-F10  
Support plate for handwheel adaptable for COL2A-F10 / COL3A-F10

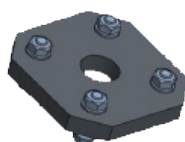

Matière : POM

Material: POM

Ref.

GUICOLA

VOLANT | HANDWHEEL

Volant adaptable sur extension ou sur cadre  
Handwheel suitable for extension or on frame



Matière : Acier revêtu Epoxy  
Diamètre : 300mm

Material: Epoxy-coated carbon steel  
Diameter: 300mm

DN

Ref.

200-500

VOL1A

600-1000

VOL2A

PLATINE POUR MOTEUR | MOTOR PLATE

Platine pour moteur Auma  
Auma output drive

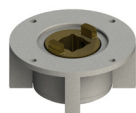

Matière : Acier  
Platine : ISO5210  
Pour montage sur extension «EXT»  
F10AU1A : monté sur extension

Material: Carbon steel  
Top mounted flange: ISO5210  
For telescopic extension mounting «EXT»  
F10AU1A: for extension

Ref.

F10AU1A

ENTRETOISE | SPACER

Entretoise



Matière : Inox 316L

Material: Stainless steel 316L

Ref.

F10AU1AS

U04 - MOTEUR VG -VANNE MURALE | U04 AUMA ACTUATOR FOR PENSTOCK

Kit motorisation Auma TRI 400V/50Hz On/Off  
3-phase Auma actuator 400V/50Hz On/Off



Moteur équipé de :  
- 2 contacts fin de course  
- 1 résistance de chauffe  
- 2 limiteurs de couple  
Commande manuelle de secours  
Indicateur visuel de position  
Protection IP68

Actuator equipped with:  
- 2 limit switches  
- 1 heat resistor  
- 2 torque limiters  
Emergency handwheel  
Visual position indicator  
IP68 protection

DN

Ref.

mm

inch

200-700

8" - 28"

SA07.6-U04B1TOR90T

800-1000

32" - 40"

SA10.2-U04B1TOR90T



Solutions for a world in motion







## VANNES À GUILLOTINE KNIFE GATE VALVES

### GÉNÉRALITÉS

Les vannes à guillotine sont toujours livrées avec le fouloir de presse-étoupe desserré. Avant toute utilisation, serrer progressivement le fouloir de presse-étoupe. (Voir Fig. 18)  
Après mise sous pression du circuit, vérifier les fuites au niveau du presse étoupe et resserrer si nécessaire.  
Respecter les positions de montage. (Voir Fig. 14)  
Respecter le sens de montage de la vanne à guillotine. (Voir Fig. 16)

Pour un montage en bout de ligne, la vanne doit être montée «entre brides». (Voir Fig. 17)  
S'assurer de la visibilité de l'indicateur.  
Avant la mise en service, surtout en cas de stockage prolongé, graisser la vis de manœuvre. (Voir Fig.19)  
Veillez au montage du tube de protection de la vis de manœuvre lors de la première installation.  
La réserve de graisse de la vis de manœuvre est assurée dans le tube de protection, offrant un graissage régulier. Assurer régulièrement le maintien du niveau suffisant de graisse dans le tube de protection.  
Lorsqu'un moteur est monté sur une vanne, veiller à graisser la noix du moteur et la tige de la vanne.

Vanne à guillotine type sous silo (Voir Fig. 20) :  
A chaque démontage et remontage de la trappe de fond de corps, le joint de la trappe doit être changé.  
Ne démonter la trappe que si le corps de la vanne n'est plus sous pression.

### GENERALITIES

Knife gate valves are always delivered with the loosened packing gland. Before any use, tighten the gland gradually. (See Fig. 18)  
After setting under pressure on line, check the leakage on the level of the packing and tighten if necessary.  
Respect the recommended positions of assembly. (See Fig. 14)  
Respect the knife gate valve assembling way. (See Fig. 16)

For bottom line assembling the valve must be installed between flanges. (See Fig. 17)  
Be sure that the position indicator is visible.  
Before the starting, especially in case of prolonged storage, lubricate the valve stem. (See Fig. 19)  
Take care of the assembly of the protection tube of stem at the time of the first installation. The grease reserve of the stem is ensured in the protection tube, offering a regular greasing.  
Assure regularly the preservation of the sufficient level of grease in the tube of protection.  
When assembling of an electric actuator on the valve, take care to lubricate the nut of the actuator and the stem of the valve.

Under silo special knife gate valve (See Fig. 20):  
In every dismantling and reassembly of the trapdoor body, the trapdoor gasket must be changed.  
Dismantle the trapdoor only if the body of the under silo special knife gate valve is not any more under pressure.

### Types de montage Type of assembly



**Montage type 1**  
Avec vis + écrous  
et ensemble boulons.  
**Assembly type 1**  
With screws + nuts  
and bolts set.

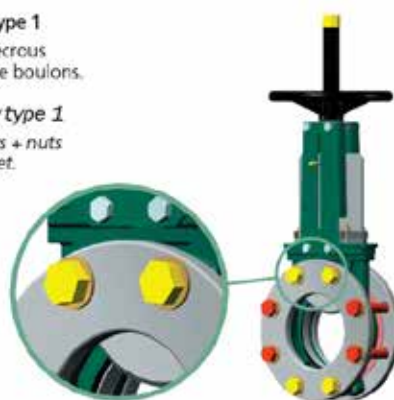

**Montage type 2**  
Avec vis et ensemble  
boulons.  
**Assembly type 2**  
With screws and  
bolts set.



# NOTICE D'INSTALLATION ET D'UTILISATION

## USE AND INSTALLATION NOTE



VANNE À GUILLOTINE  
KNIFE GATE VALVE

### RACCORDEMENT ISO PN 10 POUR BRIDES TYPE 11B / ISO PN 10 CONNECTION FOR FLANGES TYPE 11B

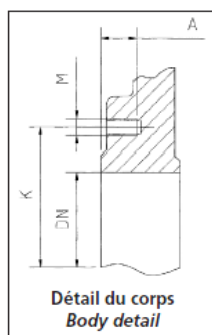
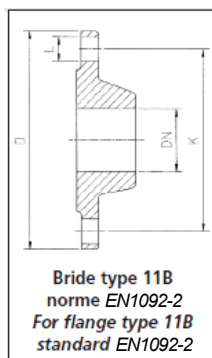

DN		Raccordement de la bride Flange connection			Equipement pour montage entre 2 brides Equipment for assembling between 2 flanges			
		Diamètre extérieur ø D Exterior diameter	Diamètre de perçage des trous ø K Drilling diameter	Trous Nombre x ø L Number of holes x ø L	Vis + écrou type 1 (jaune) Nombre x M-l Screw + nut type 1 (yellow) Number x M-lg	Vis type 2 (jaune) Nombre x M-l Screw type 2 (yellow) Number x M-lg	Profondeur de taraudage A Threading depth	Boulons type 1 et type 2 (rouge) Nombre x M-l Bolt type 1 and type 2 (red) Number x M-lg
mm	inch	mm	mm			mm		
50	2"	165	125	4 x 18	8 x M 16-60	8 x M 16-25	8	-
65	2 1/2"	185	145	4 x 18	8 x M 16-60	8 x M 16-25	8	-
80	3"	200	160	8 x 18	8 x M 16-60	8 x M 16-30	9	4 x M 16-120
100	4"	220	180	8 x 18	8 x M 16-60	8 x M 16-30	9	4 x M 16-120
125	5"	250	210	8 x 18	8 x M 16-65	8 x M 16-30	9	4 x M 16-120
150	6"	285	240	8 x 22	8 x M 20-70	8 x M 20-35	10	4 x M 20-130
200	8"	340	295	8 x 22	8 x M 20-75	8 x M 20-35	12	4 x M 20-140
250	10"	395	350	12 x 22	16 x M 20-80	16 x M 20-40	12	4 x M 20-150
300	12"	445	400	12 x 22	16 x M 20-80	16 x M 20-40	12	4 x M 20-150
350	14"	505	460	16 x 22	20 x M 20-90	20 x M 20-45	19	6 x M 20-180
400	16"	565	515	16 x 26	20 x M 24-90	20 x M 24-50	20	6 x M 24-200
450	18"	615	565	20 x 26	28 x M 24-100	28 x M 24-55	24	6 x M 24-200
500	20"	670	620	20 x 26	28 x M 24-100	28 x M 24-55	24	6 x M 24-200
600	24"	780	725	20 x 30	28 x M 27-110	28 x M 27-50	24	6 x M 27-200
700	28"	895	840	24 x 30	32 x M 27	32 x M 27	-	8 x M 27-220
800	32"	1015	950	24 x 33	32 x M 30	32 x M 30	-	8 x M 30-220
900	36"	1115	1050	28 x 33	40 x M 30	40 x M 30	-	8 x M 30-220
1000	40"	1230	1160	28 x 36	40 x M 33	40 x M 33	-	8 x M 33-220
1200	48"	1455	1380	32 x 39	44 x M 36	44 x M 36	-	10 x M 36-240



DN 50-65



DN 80-200



DN 250-300

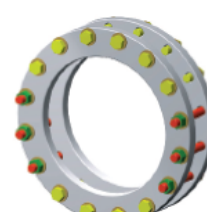

DN 350-400

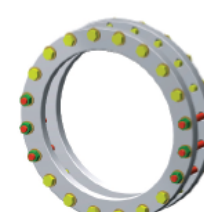

DN 450-600



Les vis en jaune  
Screws in yellow



Les boulons en rouge  
Bolts in red

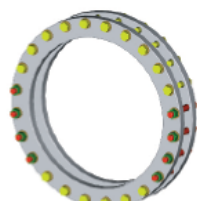

DN 700-800



DN 900-1000



DN 1200

### COUPLE DE SERRAGE / TIGHTENING TORQUE

Acier normalisé classe 8-8 (suivant norme DIN ISO 898/1)

8-8 class standard steel (following standard DIN ISO 898/1)

DN (mm)	50	65	80	100	125	150	200	250	300	350	400	450	500	600	700	800	900	1000	1200
Filetage / Threading	M 16	M 16	M 16	M 16	M 16	M 20	M 20	M 20	M 20	M 20	M 24	M 24	M 24	M 27	M 27	M 30	M 30	M 33	M 36
Couple de serrage Tightening torque (Nm)	60	60	60	60	60	70	70	70	70	70	150	150	150	230	230	300	300	400	500
	190	190	190	190	190	370	370	370	370	370	650	650	650	940	940	1290	1290	1740	2250



# NOTICE D'INSTALLATION ET D'UTILISATION

## USE AND INSTALLATION NOTE



VANNE À GUILLOTINE  
KNIFE GATE VALVE

### ■ Position des vannes / Valve position

La vanne peut être montée dans toutes les positions. Cependant, nous préconisons des positions favorables.

*The valve can be installed in any position; however, we recommend the below positions.*

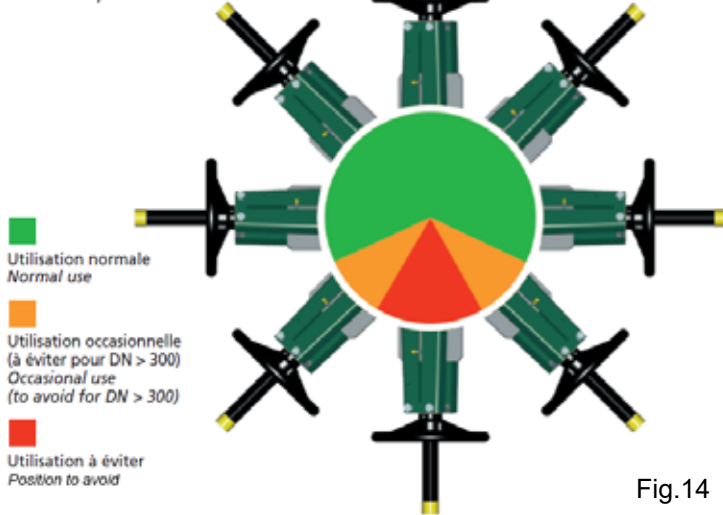

■ Utilisation normale  
Normal use

■ Utilisation occasionnelle  
(à éviter pour DN > 300)  
Occasional use  
(to avoid for DN > 300)

■ Utilisation à éviter  
Position to avoid

Fig.14

### ■ Manutention des vannes Valve handling

Avant le montage, veuillez à manutentionner la robinetterie avec précaution.  
*Before installation, handle the valve with care.*



Fig.15

### ■ Sens de montage VG / VG Knife gate valve installation direction

La vanne est unidirectionnelle, elle doit être installée de façon à ce que la pression du fluide plaque la pelle sur le joint. Le sens de montage inverse est fortement déconseillé et relève uniquement de la responsabilité de l'utilisateur. Veuillez donc à un montage conforme au sens de la flèche sur le corps (applications hydrauliques).

*The valve is unidirectional and must be installed so that the fluid pressure presses the gate against the gasket. Install the valve following the arrow on the body (hydraulic applications).*

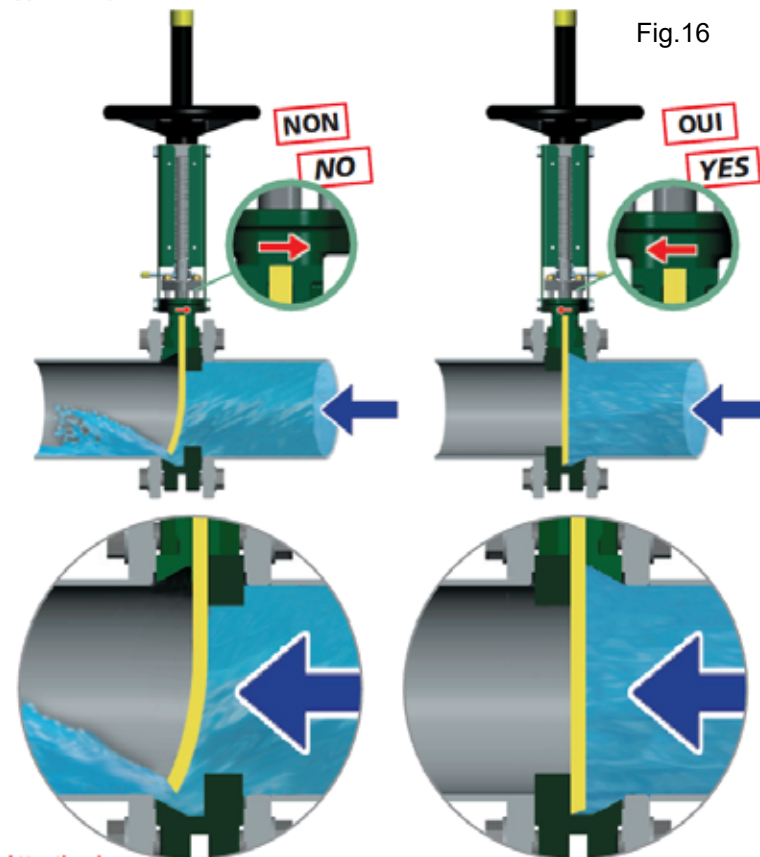

Fig.16

**Attention !**  
Pour des applications de transport pneumatique ou de pulvérulents, nous consulter.  
*For use in pneumatic or powder transport, contact us.*

### ■ Montage en bout de ligne End-of-line installation

Pour un montage en bout de ligne, la vanne doit être montée «entre brides».  
*For end-of-line installation, the valve must be installed between flanges.*



Fig.17



# NOTICE D'INSTALLATION ET D'UTILISATION

## USE AND INSTALLATION NOTE



### ■ Serrage du fouloir de presse-étoupe / Tightening the packing gland

Les vannes sont toujours livrées avec le fouloir de presse-étoupe desserré.  
*The valve is always delivered with the packing gland loosened.*

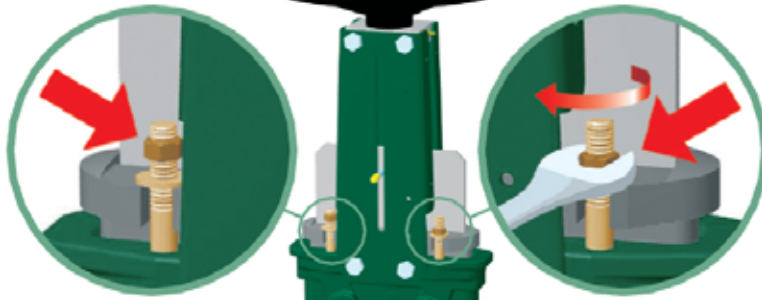

Avant toute utilisation, serrer progressivement et modérément le fouloir de presse-étoupe, de préférence, avec la vanne en charge pour s'assurer de l'étanchéité.

*Before any use, gradually and moderately tighten the packing gland with the valve under pressure to ensure watertightness*

Fig.18

### ■ Montage sous silo : sens de montage VGS *Under silo : VGS knife gate valve assembling way*

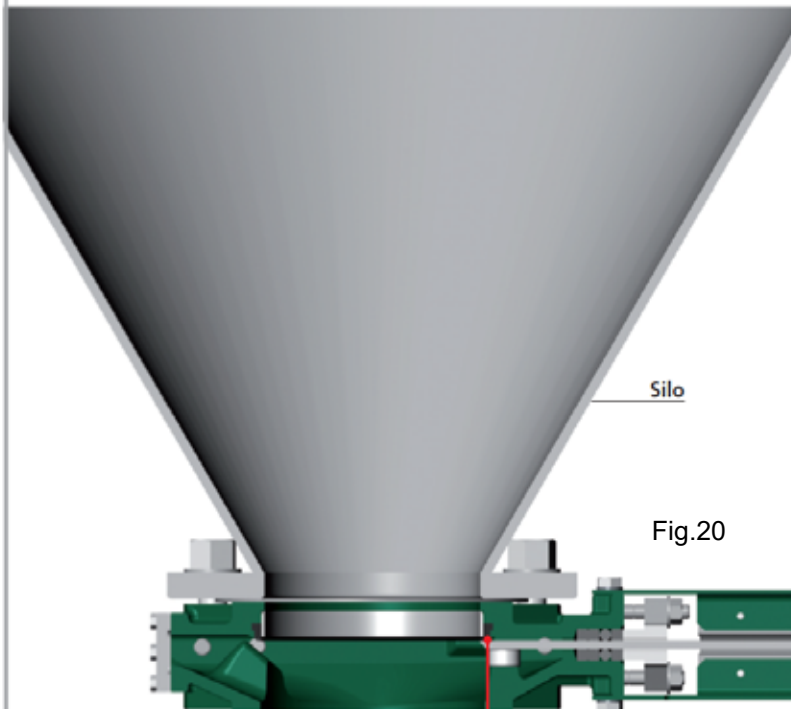

Pour une bonne évacuation, il est recommandé de monter la vanne avec le joint du même côté que le produit.  
*To ensure proper discharge, it is recommended to install the valve with the gasket side closer to the interior of the silo.*

### ■ Graissage et tube de protection *Greasing and protection tube*

Veillez au montage du tube de protection de la vis de manœuvre lors de la première installation. La réserve de graisse de la vis de manœuvre est assurée dans le tube de protection, offrant un graissage régulier.  
*Ensure the assembly of the stem's protection tube during the first installation. The stem's grease reserve is located in the protection tube, regularly greasing the stem.*

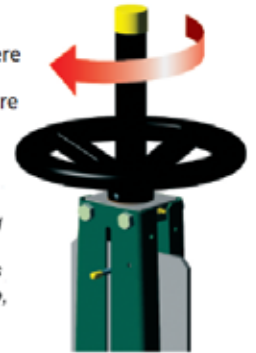

En cas de stockage prolongé ou de faible fréquence des manœuvres, graisser la vis de manœuvre régulièrement.  
*In the event of extended storage or a low frequency of operation, lubricate regularly the stem.*



Fig.19

### ■ Supportage des vannes / Valves support

Les vannes manuelles au diamètre important, les vannes munies d'actionneurs lourds tels que vérins, moteurs électriques..., doivent être supportées à l'aide de la plaquette de supportage fournie, lorsqu'elles sont montées en position horizontale ou inclinée.  
*Large diameter manual valves and valves with heavy actuators or motors must be supported using the supplied support plate during horizontal or slanted installation*

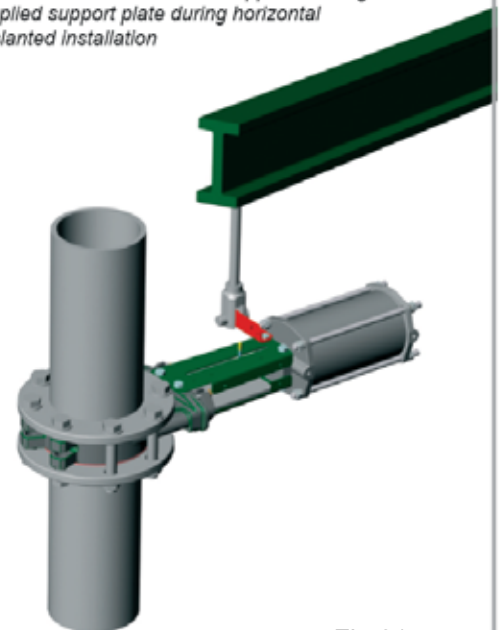

Fig.21



# NOTICE D'INSTALLATION ET D'UTILISATION USE AND INSTALLATION NOTE



## REPLACEMENT DES JOINTS / PACKING AND SEAT REPLACEMENT

Les pièces généralement remplacées sont la garniture de presse-étoupe, le siège de la vanne, les joints du vérin (en cas de commande pneumatique) et la pelle. Leur durée de vie dépend largement des cycles d'utilisation en pression, température, quantité de manœuvres, agressivité chimique, etc.

Il est recommandé de contrôler l'alignement «pelle / organe de manœuvre» dans le corps de la vanne avant de resserrer complètement les plaques supports.

*Spare parts include: packing, valve seat, gasket (for pneumatic actuators) and the gate. Their lifespan depends largely on the working pressure and temperature, the number of manoeuvres, use with aggressive chemicals, etc.*

*It is necessary to control the alignment of the gate in the body with the actuator before fully screwing the support plates.*

### Remplacement de la garniture de presse-étoupe :

- Dépressuriser le circuit et mettre la vanne en position fermée.
- Désaccoupler la pelle (1) et la tige.
- Desserrer les écrous (2) du fouloir et enlever celui-ci (8).
- Oter les anciennes tresses (5) et le joint torique (6) puis nettoyer le logement (7).
- Placer les nouvelles tresses (5) et le joint torique (6) en alternant les jointures (voir figure A).
- Replacer le fouloir (8) et les écrous (2) de celui-ci.
- Refixer la tige sur la pelle (1).
- Remettre le circuit en charge tout en resserrant les écrous du fouloir (2) jusqu'à obtenir l'étanchéité.

### Packing replacement:

- Ensure that the pipe is no longer under pressure and that the valve is closed
- Disconnect the gate (1) and stem
- Unscrew the packing gland nuts (2) and remove the packing flange (8)
- Remove the old packing and O-ring (5) (6) and clean the inside (7).
- Install the new packing and O-ring alternating the position of the openings (see fig. A).
- Re-fix the packing flange (8) with its nuts (2).
- Fix the stem on the gate (1)
- Put the pipe under pressure while tightening the packing gland nuts (2) until the valve is watertight.

### Remplacement du joint de pelle (sur vannes étanches) :

- Déposer la vanne.
- Retirer l'organe de manœuvre.
- Enlever la pelle (1).
- Oter la bague support en inox (4).
- Oter le joint usagé (3) et nettoyer son emplacement.
- Placer le nouveau joint moulé (3) dans son logement.
- Monter la bague support (4) en la martelant sur tout le diamètre pour la placer dans son logement (voir figure B).
- Replacer la pelle (1) sans endommager le siège.
- Refixer l'organe de manœuvre et faites plusieurs manœuvres d'ouverture et de fermeture avant de replacer la vanne sur l'installation.
- Avant de resserrer complètement les plaques supports contrôler l'alignement de la pelle dans le corps avec l'organe de manœuvre (surtout en pneumatique).

### Replacement of Valve Seat (on watertight valve):

- Remove the valve
- Remove the actuator
- Remove the gate (1)
- Remove the stainless steel ring (4)
- Remove the gasket (3) and clean its spot.
- Insert the new shaped gasket (3)
- Insert the support ring (4), hammering it into place along the whole circumference.
- Put back the gate without damaging the gate (1)
- Reattach the actuator and open and close the valve a few times before reinstalling the valve on the pipe.
- Before fully screwing the support plates, ensure the alignment of the gate in the body with the actuator (especially with pneumatic actuators)

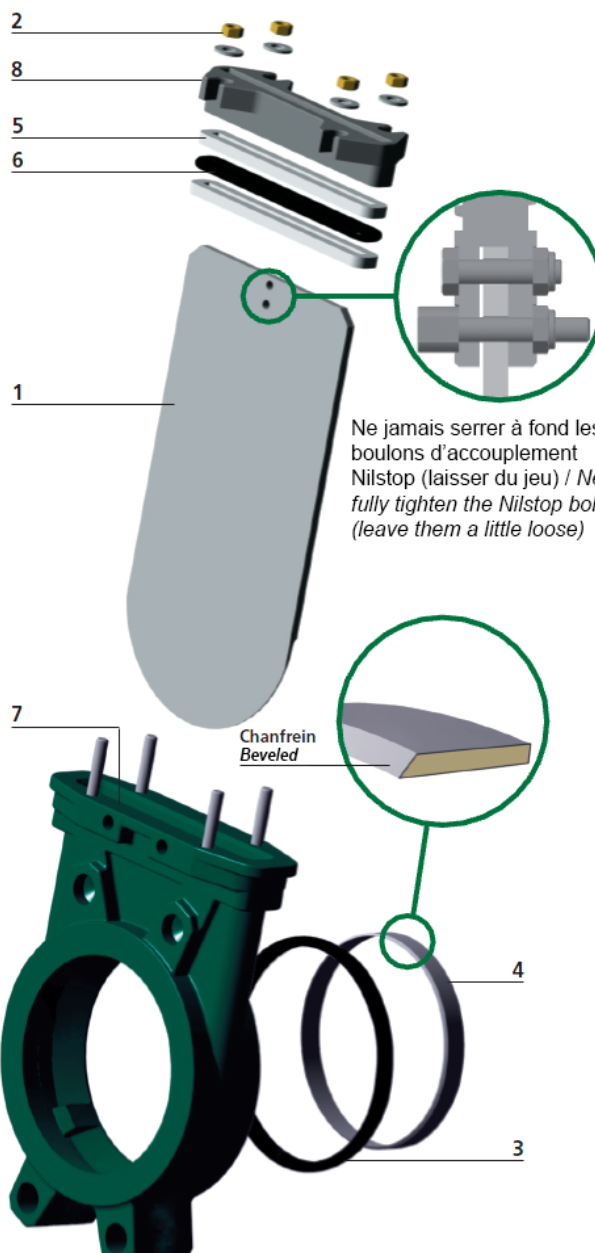

Ne jamais serrer à fond les boulons d'accouplement Nilstop (laisser du jeu) / Never fully tighten the Nilstop bolts (leave them a little loose)

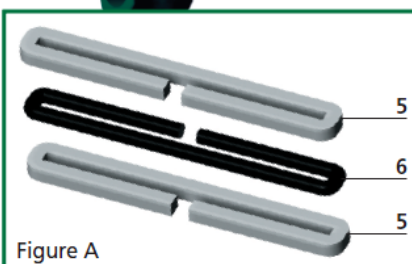

Figure A

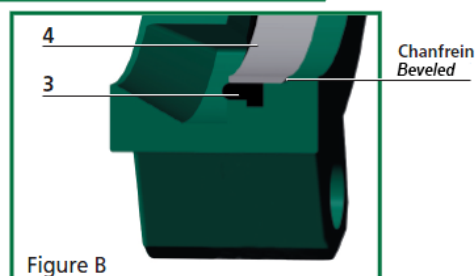
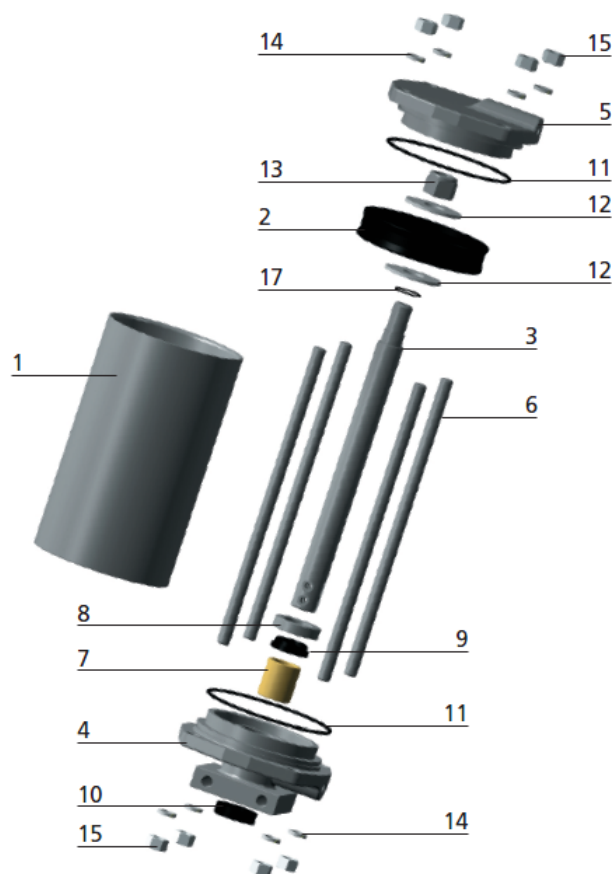

Figure B



### PIÈCES DÉTACHÉES DE VÉRIN PNEUMATIQUE DOUBLE EFFET DOUBLE-ACTING PNEUMATIC ACTUATOR SPARE PARTS



Vérin pneumatique  
double effet  
Double acting pneumatic  
actuator

- |                                     |                                      |                                       |
|-------------------------------------|--------------------------------------|---------------------------------------|
| 1. Tube                             | 7. Bague de guidage / Guiding ring   | 13. Ecrou frein / Self-locking nut    |
| 2. Piston                           | 8. Ecrou de blocage / Locking nut    | 14. Rondelle / Washer                 |
| 3. Tige / Stem                      | 9. Joint d'étanchéité / Gasket       | 15. Ecrou / Nut                       |
| 4. Flasque inférieur / Lower flange | 10. Joint cache-poussière / Dust cap | 16. Ressort de rappel / Return spring |
| 5. Flasque supérieur / Top flange   | 11. Joint torique / O-ring           | 17. Joint / Gasket                    |
| 6. Tirants / Rods                   | 12. Rondelle / Washer                |                                       |

Vérin pneumatique double effet\*  
Double acting pneumatic  
actuator\*

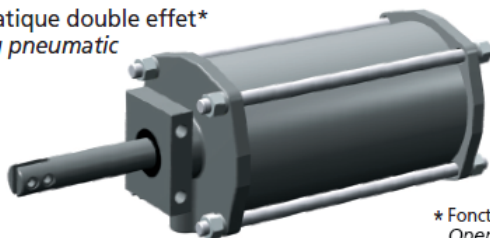

Vérin pneumatique double effet\*  
pour vanne DN > 300  
Double acting pneumatic actuator\*  
for valve DN > 300

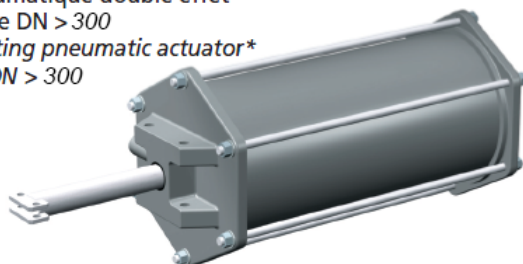

\* Fonctionnement avec air lubrifié (P maxi = 7 bar / Ps = 6 bar / P mini = 5 bar)  
Operation with lubricated air (maxi pressure 7 bar, working pressure  
6 bar, minimum pressure 5 bar).



### INSTRUCTIONS SPÉCIFIQUES POUR LA MISE EN PLACE ET L'UTILISATION DE LA COMMANDE MANUELLE DE SECOURS DU VÉRIN PNEUMATIQUE DOUBLE EFFET

- 1 – Couper l'alimentation pneumatique du vérin (débrancher l'electrodistributeur).
- 2 – Déposer le capot de protection se situant du côté de l'accroche de la chaîne. (Voir Fig.22)
- 3 – Dévisser le maillon rapide de la chaîne pour libérer le volant. (Voir Fig.23)
- 4 – Faire descendre la tige en actionnant le volant dans le sens «CLOSE» (Voir Fig. 24) jusqu'à ce que l'empreinte mâle de la tige du vérin coïncide dans l'empreinte femelle de la tige du volant. (Voir Fig. 25)  
Attention : Il peut être nécessaire de maintenir la tige pour bloquer sa rotation et permettre sa translation. (Utiliser des gants de protection)

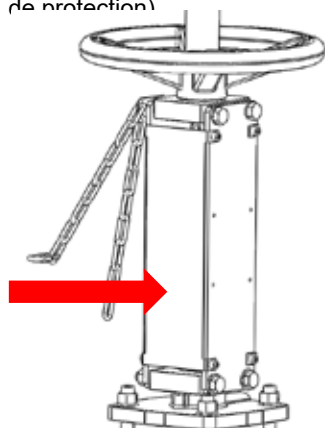

Fig.22

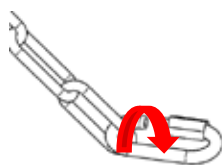

Fig.23

### SPECIAL INSTRUCTIONS FOR THE INSTALLATION AND THE USE OF MANUAL EMERGENCY OPERATING OF THE DOUBLE-ACTING PNEUMATIC ACTUATOR

- 1 - Close pneumatic supply of pneumatic actuator.
- 2 - Disassemble the safety protection being situated near the chain fixation. (See Fig. 22)
- 3 - Discrew the chain fast link to release the handwheel. (See Fig. 23)
- 4 - Make go down the stem by operating the handwheel in the "CLOSE" direction (See Fig. 24) until the male imprint of the pneumatic actuator stem coincides in the female imprint of the handwheel stem. (See Fig. 25)  
Attention: It can be necessary to maintain the stem to block his rotation and allow his translation. (Use oven gloves)

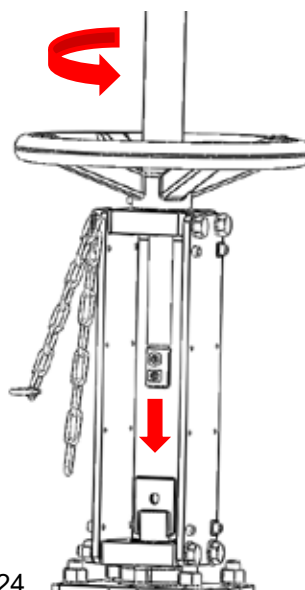

Fig.24

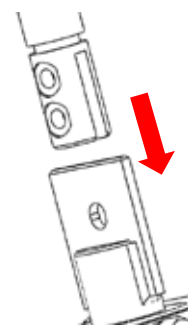

Fig.25

- 5 – Goujiller les deux tiges ensemble à l'aide de l'axe fixé sur la chaîne (Voir Fig. 27), après avoir préalablement retiré la goupille épingle (Voir Fig. 26). Une fois l'axe inséré, insérer la goupille épingle sur celui-ci. (Voir Fig. 28)

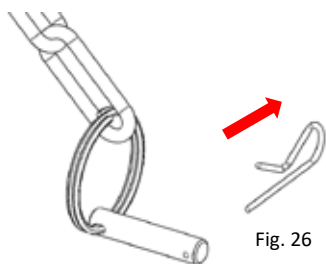

Fig. 26

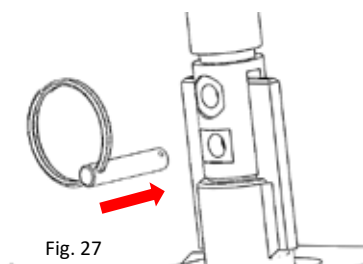

Fig. 27

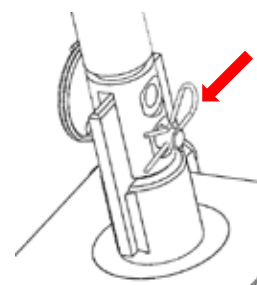

Fig. 28

- 6 – La commande manuelle de secours est prête à être utilisée pour ouvrir ou fermer la vanne.

- 6 - The manual emergency operating is ready to be to use to open or close the valve.



### INSTRUCTIONS SPÉCIFIQUES POUR DÉSACCOUPLER LA COMMANDE MANUELLE DE SECOURS DU VÉRIN PNEUMATIQUE DOUBLE EFFET

### SPECIAL INSTRUCTIONS TO UNCOUPLE THE MANUAL EMERGENCY OPERATING OF THE DOUBLE-ACTING PNEUMATIC ACTUATOR

1 - Désolidariser les deux tiges ensemble en ôtant l'axe fixé sur la chaîne (Voir Fig. 30), après avoir préalablement retiré la goupille épingle (Voir Fig. 29). Une fois l'axe retiré, insérer la goupille épingle sur celui-ci. (Voir Fig. 31)

1 - Separate the two stems by removing the axis fixed to the chain (See Fig. 30), having before removed the safety pin (See Fig. 29). Once out-of-the-way axis, insert the safety pin to this one. (See Fig. 31)

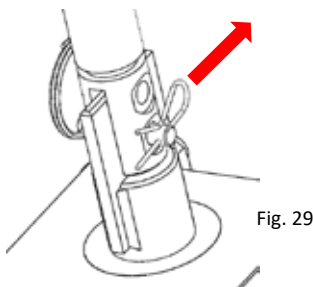

Fig. 29

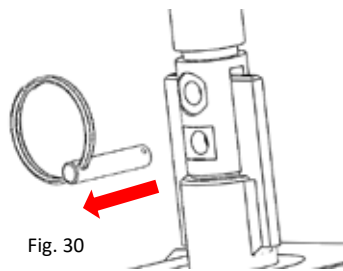

Fig. 30

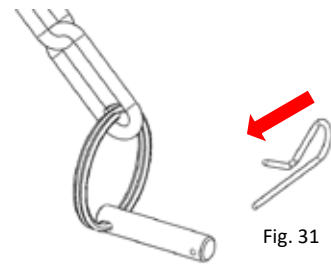

Fig. 31

2 - Faire remonter la tige en actionnant le volant dans le sens «OPEN» jusqu'à ce que la commande manuelle de secours bute dans sa position la plus haute. (Voir Fig. 32)

2 - Make go up the stem by operating the handwheel in the "OPEN" direction until the manual emergency operating to be in its high position. (See Fig. 32)

Attention : Il peut être nécessaire de maintenir la tige pour bloquer sa rotation et permettre sa translation. (Utiliser des gants de protection)

Attention: It can be necessary to maintain the stem to block his rotation and allow his translation. (Use oven gloves)

3 - Verrouiller le volant à l'aide de la chaîne et du maillon rapide. (Voir Fig. 33)

3 - Lock the handwheel by means of the chain and of the fast link. (See Fig. 33)

4 - Assembler les capots de protections de la partie commande manuelle de secours.

4 - Assemble the safety protections of manual emergency operating. (See Fig. 34)

5 - Alimenter en air comprimé le vérin pneumatique double effet.

5 - Fed with compressed air the double-acting pneumatic actuator.

6 - La commande par vérin pneumatique est prête à être utilisée pour ouvrir ou fermer la vanne.

6 - The operating by pneumatic actuator is ready to be to use to open or close the valve.

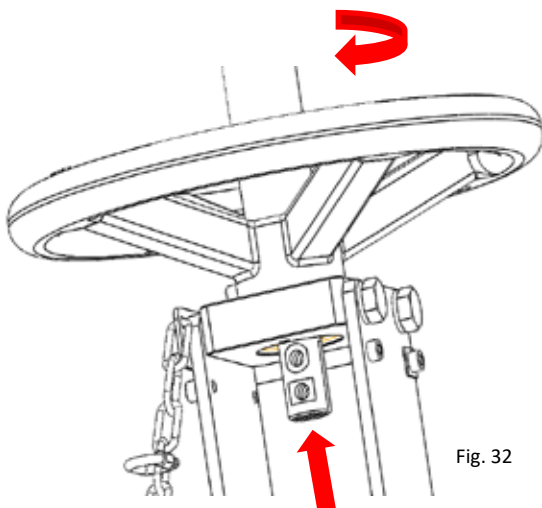

Fig. 32

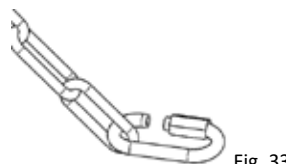

Fig. 33

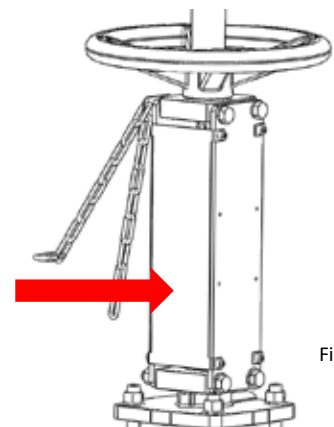

Fig. 34